

# African Research Review

---

An International Multidisciplinary Journal, Ethiopia

Vol. 8 (2), Serial No. 33, April, 2014:68-82

ISSN 1994-9057 (Print)

ISSN 2070--0083 (Online)

DOI: <http://dx.doi.org/10.4314/afrev.v8i2.5>

---

## Preliminary Design of an Automated White Board Cleaner

**Simolowo, O. E.** - Department of Mechanical Engineering

University of Ibadan, Ibadan, Oyo State, Nigeria

E-mail: [esimmar@yahoo.com](mailto:esimmar@yahoo.com)

Tel: +234(0)8059541882

&

**Ngana, O. C.** - Department of Mechanical Engineering

University of Ibadan, Ibadan, Nigeria

### Abstract

*The work presented in this paper is on the preliminary design and fabrication of an automated whiteboard cleaner. The objective here in is to reduce the man-power involved in cleaning white boards after use. Though the use of smart boards is increasing, many institutions in the developed and developing world still make use of white boards. The Autodesk software was used for the CAD drawing and thereafter the design analyses and fabrication were done. The auto-board was designed to be powered by a single phase 0.6 HP electric motor. The chain drive parameters were determined based on estimations of the centre distance between the sprockets, the required cleaning time, number of sweeps, total number of chain links and the expected performance. The cleaning efficiency of the auto-white board cleaner*

*is estimated to be better than the manual operation when the equipment is fully completed.*

**Key words:** Automated-white board-cleaner, Design-analyses, Preliminary-fabrication

## **Introduction**

A whiteboard or dry erase board is a name for a glossy surface, most commonly coloured white, where non – permanent markings can be made. Whiteboards operate analogously to chalkboard in that they allow markings to temporarily adhere to the surface of the board. The popularity of whiteboards increased rapidly in the mid-1980s and they have become a fixture in many offices, meeting rooms, school classrooms and other work environments. In the mid-1960s, the first whiteboard (also called marker boards) began to appear on the market. In classrooms, their widespread adoption didn't occur until the late 1980s and early 1990s when concern over allergies and other potential health risks posed by chalk dust prompted the replacement of many blackboards with whiteboards.

The first whiteboards were very expensive and were made of a melamine surface. It was the “perfect” solution to the chalkboard, except that it ghosted in a short time and was not easy to keep clean. In our lecture rooms, the dire need for a duster that would be readily available at all times for cleaning the whiteboards has been a major concern, the height of some boards cleaners also affect the section of the board to be cleaned. Even when the board cleaners are available, it takes lecture time away from the lecturer to erase the board. This need for a faster, time saving and readily available cleaner has given birth to the design of an automated white board cleaner that can clean the board in the least amount of the time possible.

## **Background knowledge and project concept**

The mechanism of the automated board cleaner entails a horizontal motion. The design is aimed at reducing the stress of manual cleaning. The duster which spans horizontally across the width of the board is to

clean to and fro across the board. The design is such that when the switch is turned on, the motor transmits energy which turns the shaft which in turn, drives the pulley. The duster is fixed to the pulley chains which move to and fro (horizontal motion) along its plane, thereby cleaning the board. The idea behind the project basically is to simplify the manual use of duster which is quite tedious. This came about as a result of the observation carried out during lectures. Lecturers or students waste time while cleaning the board, hence slowing down lecture hours. Although, different designs have evolved over the years as regards the fabrication of an automated whiteboard cleaner, the main purpose of these designs have not combated the stressful nature of cleaning boards. This project adds to the variety of designs aimed at mitigating the stress associated with cleaning boards.

### **Problem of existing design and objective of new design**

In the light of designing an automated whiteboard cleaner, the limitations of two major existing designs will be considered. That is, the electric board cleaner and the automatic whiteboard cleaner which makes use of belts. Most belts have low wear and tear resistance and with the frequent operation of the duster (i.e the cleaning process), the belt is likely to cut and hence makes the device or the cleaner less useful. In the process of trying to change the belt, the whole components may have to be loosened which is time – consuming.

However, as for the case of the electric board cleaner, the idea of applying manual effort still comes in. The difference being that effort applied is less since it is powered electrically. This project is aimed at modifying the automatic whiteboard cleaner by replacing the belts with chains which will improve the efficiency and effectiveness of the cleaner. The objective of this project is to reduce the stress of cleaning the board by using an automated duster. This objective would be achieved through the following specific objectives (i) conceptualization of an automated whiteboard cleaner (ii) preliminary and detailed design of new mechanism (iii) fabrication of the

automated whiteboard cleaner (iv) performance testing of the automated whiteboard cleaner

### **Description of other related works**

A whiteboard is a name for any glossy, usually white surface for non-permanent markings. Whiteboards are analogous chalkboards, allowing rapid working and erasing of markings on their surface (Ariyama, 2002; Pugh *et al*, 2003). Different board cleaners have been invented and all are aimed at reducing the stress of cleaning (Atwood *et al.*, 2002; Jang, 2002). Some of which will be discussed in this chapter. The three major inventions are; the automated erasure system, electric board cleaner and a differentiating mobile robot cleaner. The automated erasure system is suitable for erasure of non – permanent markings from boards such as whiteboards (whether electronic or not) or other boards (e.g. chalkboard). The automatic board erasure system includes an eraser member that is directed across the surface of the board to erase any non – permanent markings that have been previously placed on the board (i.e. on the surface of the board).

The automatic board erasure system also includes a first rod and a second rod. The first rod has pulleys and belt affixed thereto, and the second rod has pulley and belt affixed thereto when the erasure process is to be performed, a motor drives the rod in a rotational manner. The rotation of the rod causes the pulley and belts to rotate. The eraser member is coupled to the belt and the board. Hence, as the motor drives the rod which in turn drives the pulley and the belts and are also driven such that the eraser member is moved across the surface of the board, thereby erasing any non –permanent markings there from.

In one embodiment, the eraser member extends across substantially the entire width of the board. As the motor causes the eraser member to be driven across the length of the board, the entire surface of the board is able to be erased in a uniform manner. Typically, the motor need only drive the eraser member over the board in a single pass. Still further, in order to affix the automatic board erasure system such

that it is proximate to the board to be erased, brackets can couple the first rod to the frame of the board or to a wall to which the board is attached. Likewise, brackets can be used to couple the second rod to the frame of the board or a wall to which the board is attached (Rodriguez, 2002; Ariyama, 2002).

However, for the electric board invention, it comprises of two half housings, a motor, a dust net, a film, an absorbing head, a cleaning pad and a battery case combined together. The two half housings are T- shaped, having a grip portion, a dust chamber, an inner horizontal fitting groove

Near the top of the grip portion, a threaded hole respectively in four lower corners of the grip portion and a power switch. The motor is vertically contained in the chamber of the second housing and the corresponding chamber in the first housing, having a horizontal position plate near the top and a shaft fixed with a fan. In using, (Pugh *et al* 2003) the switch of the grip portion is to be pressed to turn on the power and then the motor is electrified to rotate the fan. The cleaning pad of the absorbing head is made to contact the surface of the board by a hand gripping the grips, and then moved thereon around to rub off what is written on the board. The film is to be sucked to tilt by sucking force of the fan opening the lower end of the absorbing head so that the wiped marker is sucked into the dust net. The air sucked into the net together with the marker particles will pass through the net and flow out of the heat dispersing hole of the grip. Then the air in the room may not be polluted by marker powder. The dust net can be taken out to empty the marker particles / powder when the powder is full in the net.

Lastly, there is also a differentiating mobile robot cleaner. This mobile robot cleaner is a more recent invention. This project was inspired by the realization that erasing a whiteboard is a repetitive and tedious task. The purpose of the robot was to systematically and intelligently remove dry erase ink from the whiteboard while ignoring any ink contained within a yellow barrier. This required the integration of

mechanical, electrical and computer devices into an autonomous device. A trolley hung from a track moves one step at a time to the right while lowering and raising an erasing mechanism (Mendel, 2002). The erasing mechanism constantly checks for yellow and uses this to determine whether the eraser should be against the board or not. The result was a robot that can clean or leave behind the dry erase ink on a whiteboard without any significant human involvement.

The robot design erases marker completely or with very little residue remaining. However, the end result is decidedly inefficient. Despite great efforts made to improve and perfect the robot and its performance, it still suffers from significant limitations. For proper barrier detection, the line must be at least half inch thick and should have an extra space of a few inches above and below the safety area. (Isom, 2005). While this space is necessary to ensure proper erasure, in the end it wastes precious board space for no real reason. The top of the board is additionally limited due to the large size of the erasing mechanism. Another limitation is the very long time the robot takes to complete its task (Isom, 2005). The motors are simply not fast and strong enough therefore not making the robot useful for pressing issues. The major problem encountered with this design is its speed and lack of precision.

## **Description and operation of new design**

### **Description of new design**

The automated white board cleaner is a movable device; which is majorly made up of wood (plywood to be precise) due to its ease of fabrication and availability. Also, stainless steel was used in fabricating part of this equipment that will be in contact with the duster because of its high resistance to corrosion. Relatively, the board is heavy weighing about 28kg having an overall height of 740mm and surface area of (1210 x 270mm<sup>2</sup>). The board has a compartment upon which the motor stand, the motor, the sprockets, chains and duster are mounted. The top of the board is covered with steel to withstand the weight of the motor and other components. Also, to enable easy

fastening of the motor stand on the board. The chain spans a length of 1892.3mm and the sprocket has a diameter of 140mm. All these components are housed by a top cover. This cover has a fined surface by the side close to the motor. This is done to increase the surface area of heat sent out of the motor, hence increase the performance of the electric motor.

However, the duster is made of wood which will span the width of the board. It has a surface area of (735 x 65mm<sup>2</sup>). The design is such that the base of the duster will have a roller which will enable the duster to move across the duster while cleaning. At the extreme ends of the board, there will be pilot switches. These pilot switches are sensors which are used to stop the duster from continually being in operation when it's not needed. Also, wooden supports are embedded in the frame of the board. This is done to withstand the load of the motor and other components.

### **Machine operation**

The operation described in this section is based on the designed machine (present and future works to be done) shown in Figs. 1 and 2. The equipment is made up of a whiteboard frame, whiteboard duster, electric motor, sprocket, chain, duster and top cover. The motor to be used is a servo-motor which is to run at a relatively low speed. When the switch is turned on, current is transmitted to a variable voltage supply. This variable voltage supply is used to reduce the amount of voltage going into the motor hence slowing down the speed. The current is then transmitted to the motor which then drives the shaft. This shaft is connected to a sprocket and drives it by the help of a keyway. The sprockets are designed to be supported by bearings which are well lubricated to reduce friction between the shaft and the sprockets. As the shaft drives the sprocket, the duster which is attached to the roller chain cleans the board in a translator manner from left to right and vice-versa. In the operation, there is a conversion from rotary motion to translator motion. Once the duster gets to either ends of the board, it stops. This done by the help of a

pilot switch (sensor), which is attached either ends of the frame of the board. As soon as the duster touches the pilot switch and compresses it, a signal is sent to the electric motor which triggers it to stop. As the motor is in operation, heat will be released from the motor. To cater for this, the top cover is provided with a finned surface which is open to allow for the escape of heat and prevent the motor from damaging.

### Design of components of automated board cleaner

#### Frictional power required for cleaning

The free body diagram of the duster resting on the board is shown in Figure 3. The force  $P_1$  required to move the block of weight  $W$  along a horizontal plane with uniform speed is given by equation (1) (Khurmi, 1967).

$$P_1 = F = \mu R = \mu W \text{----- (1)}$$

The resultant of the frictional resistance of the duster,  $F$  and the normal direction  $R$  is represented by  $R_1$  and the angle between  $R_1$  and  $R$  is termed the angle of friction  $\Phi$ .

$$F = \mu mg \text{ ..... (2)}$$

Where  $\mu$  = coefficient of friction, The duster has a mass ( $m$ ) and  $g$  is the acceleration due to gravity. Considering the material of the whiteboard, porcelain is used. The coefficient of friction is between 0.06 – 0.12. This is the ratio of tangential force to normal load during a sliding process (William J. O'Brien, 1996). Frictional force (limiting) is represented as  $F$  and  $R$  is normal reaction between the two bodies i.e. the white board and the duster.

To set the velocity ( $V$ ), the distance ( $S$ ) travelled by the duster on the board during cleaning operation is divided by the time ( $T$ ) it will take to clean as presented in equation (3).

$$V = S/T \text{..... (3)}$$

The frictional power ( $P$ ) required by the duster for cleaning is determined using equation (4)



$$P_1 = F \times v \dots\dots\dots (4)$$

The other factors we shall be considering for the power needed by the motor are the chains and sprockets. Chains are mostly used to transmit motion and power from one shaft to another chains are used for long center distance of up to 8 meters. The chain is used for velocities up to 25m/s and for power up to 110kW.

**Power transmission for chain drive**

Shown in Figure 4 is the sprocket used in the chain drive. This design analysis is based on closed joint type chains. These chains are used for conveying materials at a speed up to 2.1m/s. To get the diameter of the sprocket, the diameter of the pitch circle in a sprocket must be known where D is diameter of the pitch circle and T is number of teeth on the sprocket. The frictional power is also given by equation (5) (Gupta, 1967)

$$P_2 = \frac{W * V}{n * K_s} \dots\dots\dots (5)$$

Where W is breaking load in Newton, V is velocity of chain in m/s, n is factor of safety, k is service factor.

The pitch  $P_{pitch}$  of the chain is given by equation (6). From equation (6), the diameter (D) and angles ( $\theta$ ) of the sprocket can be calculated using equations (7) and (8)

$$P_{pitch} = AB = 2A \sin (\theta/2) = 2 \times (D/2) \sin (\theta/2) \dots\dots\dots (6)$$

$$\text{Where } \theta = 360^0/T \dots\dots\dots (7)$$

$$D = P_{pitch} \operatorname{cosec} (180^0/T) \dots\dots\dots (8)$$

**Length of the chain**

The length of the chain (L) is calculated from equation (9). The centre distance between the both sprockets can be used to estimate the number of chain links. After getting the center distance, the number of

chain links (k) is counted to be 273 and the estimated total number of chain links used is taken as 291.

$$L = K P_{\text{pitch}} \text{-----} (9)$$

### Factor of safety for the chain drives

The factor of safety for chain drives is defined as the ratio of the breaking strength of the chain to the total load on the driving side of the chain. Considering the chain that is being used for the fabrication of the automated white board cleaner, which is a bush roller chain, with a pitch of 6.35mm, and speed of 70 rpm, the factor of safety for the chain will be 8.55 and the breaking load will be 4274.185N (machine design, Gupta).

The velocity of the chain will be the same as that required to move the duster through the required length.  $K_s$  is service factor and given by equation (1) where,  $K_1$  the load factor (= 1) for constant load,  $K_2$  is lubrication factor (= 1.5) for periodic lubrication,  $K_3$  is rating factor (= 1.5) for continuous service

$$K_s = k_1 \cdot k_2 \cdot K_3 \text{-----} (10)$$

Therefore, the Power transmitted by the chain is calculated using equation (5). The total power  $P_T$  transmitted or needed for the electric motor is

$$P_T = P_1 + P_2 \text{-----} (11)$$

The following are the advantages and disadvantages of chain drive over belt drive. The advantages are (i) they occupy less space in width than a belt or rope drive. This is because the chains are made of metals. (ii) It may be used for both long as well as short distances. (iii) It gives high transmission efficiency up to 98%. (iv) It gives lighter loads on the shaft. (v) It has the ability to transmit motion to several shafts by one chain only. (vi) It can be operated under adverse temperature and atmospheric conditions. The disadvantages are: (1)

The production cost of chains is relatively high. (ii) The chain drive needs accurate mounting and careful maintenance, particularly lubrication. (iii) The chain drive has velocity fluctuations especially when unduly stretched.

### **Conclusion and recommendation**

The objective of this work which is to design an automated white board cleaner has been achieved to an extent. There is need for further fabrication works. The structures of the chains and sprocket were conceived to fit properly into the cleaning mechanism, but due to inadequate tensioning, prevented the automated duster from performing the required function adequately.

The gear mechanism could have been used to reduce the speed of the motor, but considering the weight which it might have on the machine, variable speed regulators were inculcated instead. Due to the forward motion of the duster, sensor was needed to trigger off the motor whenever the duster gets to the end of the board. This can be used to prevent damage of the motor.

Finally, the automated duster when fully completed will give an effective cleaning after two to three sweeps. It is recommended that the machine be improved in terms of tensioning of the chains to ensure an effective cleaning and that rollers are placed at the base just in front of the duster, creating a groove were it can move. Finally, proper fitting of bearings on the sprocket are put in place to reduce the load on the electric motor.

## References

- Atwood, et al, (2002). "Electronic whiteboard system and method". AMA 16 (1) 5-9
- Ariyama, (2002). "Writing on dry erase whiteboards with non-permanent marker". Trans. Of ASAE 25, (6), 13-20
- Williams, J O'Brien (1999). "Biomaterials properties Database" (J.C. Ashworth. Ed), university of Michigan, page 353.
- Gupta, (1967). Design of machine elements, first edition, S. Chand and company limited, New Delhi., pp. 759 - 770
- Isom, J., (accessed 2012). "A brief history on robotics", www.Wikipedia.com
- Jang, (2002). (accessed 2012). Apparatus and a method for automatically erasing a whiteboard, www.wikipedia.com
- Menzel, P., (accessed 2012). "Robot sapiens: evolution of new species", www.wikipedia.com
- Pugh, et al. (2003). "Non permanent marker board eraser apparatus". Trans. Of ASAE 25, 763
- Rodriguez, J., (accessed 2002). "Integrated front projection digital whiteboard system". www.devilfinder.com
- Khurmi, R. S. (1967). "Engineering Mechanics", first edition, S. Chand and company, New Delhi., pg 560-577

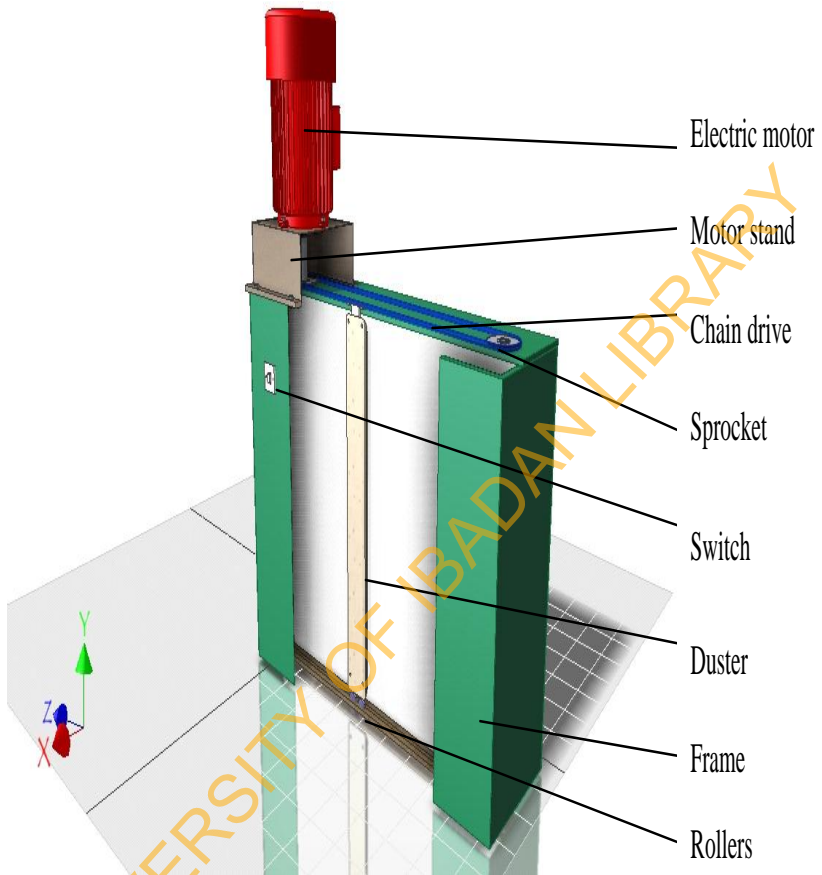

Figure 1: Isometric view of automated whiteboard cleaner

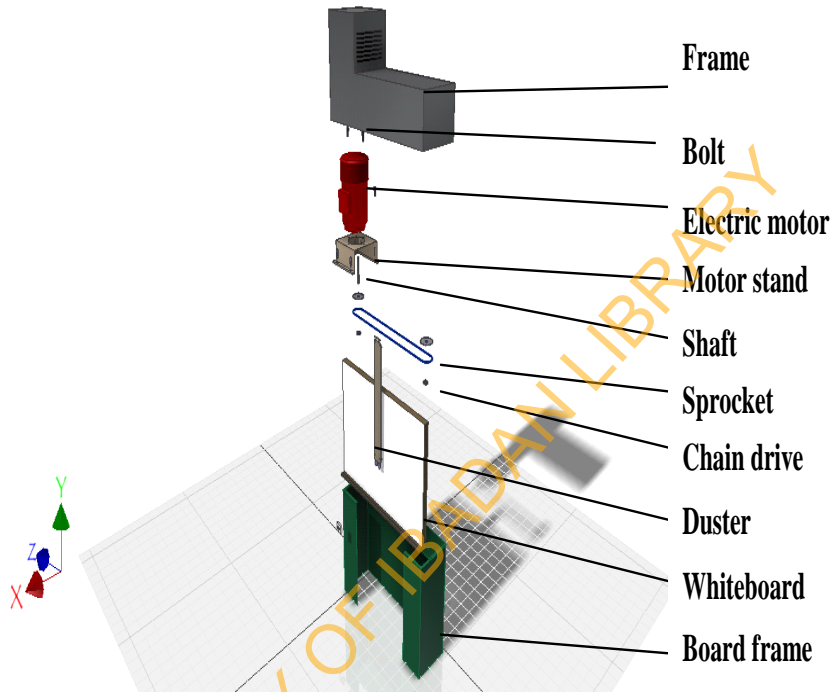

Figure 2: Exploded view of automated whiteboard cleaner

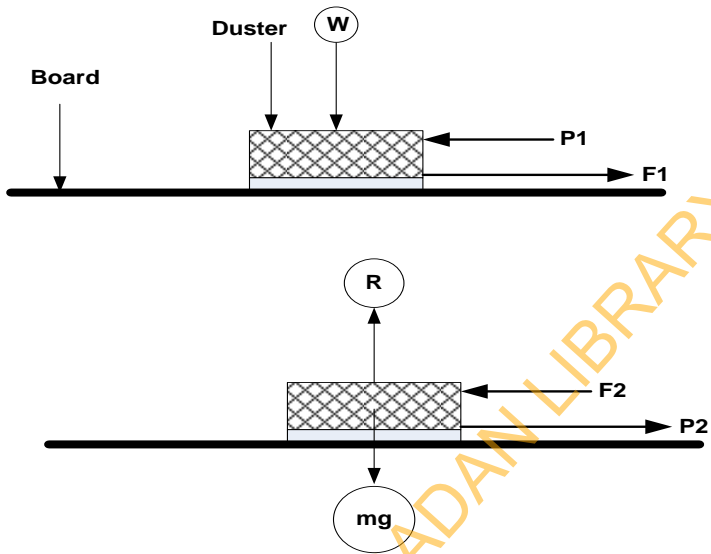

Fig 3: Free body diagram of the board and duster

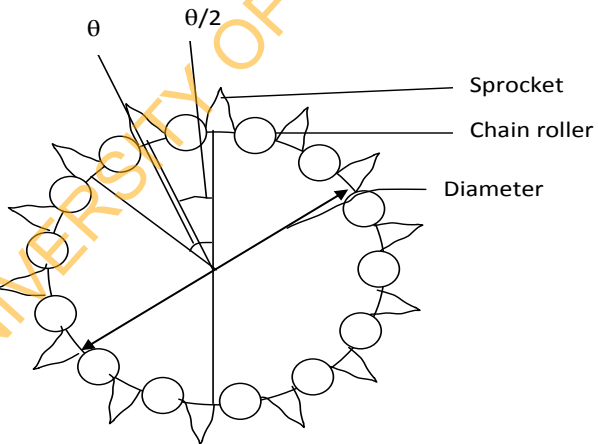

Figure 4: Type of sprocket used in chain drive