

Geophysical Investigation of Effect of Aba-Eku Public Refuse Dump Site  
in Ibadan (South-West Nigeria) on Groundwater Quality

O.I Popoola<sup>1</sup>, J.A Adegoke<sup>1</sup> and M.A Fakunle<sup>2</sup>

<sup>1</sup>Department of Physics, University of Ibadan, Ibadan.

<sup>2</sup>Department of Mathematical and Physical Sciences,  
Osun State University, Osogbo.

Abstract

Geophysical method was used to investigate the effect of Aba-Eku (N 07° 19.551' E 003° 59.027') public refuse dump site in Ibadan on groundwater quality. Four vertical electrical sounding (VES) data from the vicinity of the dump site and one VES from the control point were acquired using Schlumberger electrode configuration which were subsequently processed and interpreted based on the assess of the iterative computer model using a finite difference algorithm. The result showed that all the sides of the dump site have low resistivity values (Side A,  $\rho = 22.3\Omega m$ ; Side B,  $\rho = 31.8\Omega m$ ; Side C,  $\rho = 38.9\Omega m$  and Side D,  $\rho = 34.7\Omega m$ ) compared with the resistivity value of the control point (Glory Tower Schools,  $\rho = 60.6\Omega m$ ). The low resistivity values around the dump site is an indication of groundwater pollution. This was confirmed by the laboratory water sample analysis from the vicinity of the dump site.

**Key words:** Groundwater, Pollution, Resistivity, Schlumberger electrode configuration refuse and leachate.

1.0 Introduction:

Waste refers to useless, unused, unwanted or discarded materials including solids, liquids and gases [13]. Solid waste is the unwanted or useless solid materials generated from combined residential, industrial and commercial activities in a given area. A solid waste that has been thrown away is referred to as refuse [3]. Components of these solid wastes include food, papers leaves, dead animals, abandoned vehicles, metals, unused plastic containers, nylon, poultry feed, glass etc. Refuse were collected and dump at a spot (Aba -- Eku) assigned by Ibadan Waste Management Authority to form a refuse dump site.

Aba-Eku is one of the open and major public refuse dump sites in Ibadan and is located N 07° 19.551' E 003° 59.027'. Rain water percolate through refuse and other decaying materials in the dump site to form leachate. Leachate migrates downward and contaminates groundwater. World Bank [14] reported that the rate of urbanization in Nigeria is alarming and major cities are growing at rates between 10 - 15% per annum. So citing and development of residential quarters near public refuse dump sites (Aba-Eku) are common due to shortage of land for building to cope with the increasing rate of migration and consequently population explosion [7]. World Bank [15] also reported that only 39% of people that lives in cities have improved water source. Therefore, a large percentage of the population living in the neighbourhood of dump sites (60 %) depends on groundwater from their private wells as their main source of quality drinking water. Therefore, it become necessary to ascertain water quality of wells near this dump site under study since poor water quality may have adverse health impact. Groundwater quality characteristic near refuse dump sites have been reported in literatures e.g. [5, 6 and 8]. But similar studies in Aba-Eku dump site are scarce or lacking, so it is evidently clear to carry out this research.

Although variety of geophysical techniques are commonly employed in groundwater investigation, however, electrical resistivity method is the most unique because of its ability to detect increases in pore water conductivity [1, 2]. Electrical resistivity was chosen for this work based on results obtained by workers like [4] all confirmed the detection of contaminated substrate.

The aim of this work is to know the effect of refuse dump site on groundwater quality in and around Aba -- Eku

GEOLOGY AND HYDROGEOLOGY OF THE STUDIED AREA

The type of rock in any area is an important factor governing the characteristics of ground water. In general, sedimentary rocks due to their high porosity and permeability and layered nature are invariably good aquifers. On the other hand, Ibadan area is underlain by crystalline basement complex rocks of Precambrian age, comprising the migmatite, gneiss, the older granites and the meta-sediments [10]. The survey areas are underlain mainly by quartzite/quartz schist. The basement complex rocks composed mainly of metamorphic and igneous rock types are relatively poor aquifer. Therefore, in Ibadan area, one expects low ground water production in comparison with areas underlain by sedimentary rocks. The basement

Corresponding author: O.I Popoola : E-mail: ----, Tel. +2347035354450 --Fakunle



complex nature of the rocks in Ibadan does not, however, completely rule out the possibility of the presence of isolated good productive aquifer if proper exploratory tools are used. Figure 1 indicates the geological map of the dump site.

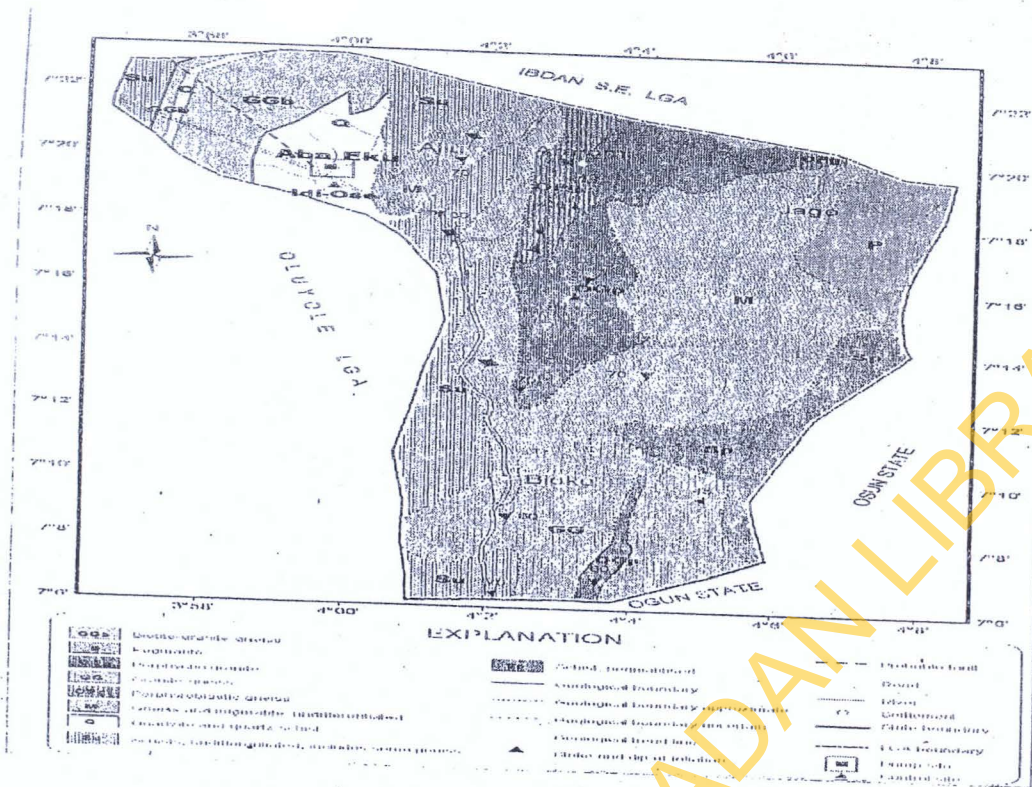

FIG. 1: Geological map of Ona-Ara L.G.A. showing dump site location [9].

**THEORY**

Resistivity method employs an artificial source of current which is injected into the ground through point electrodes. The potential difference due to the injected current is measured in the vicinity of the current flow. Since the injected current is also measured, it is possible to determine an effective or apparent resistivity of the subsurface. This provides information on the form and electrical properties of subsurface in homogeneities.

The resistance (R) of a conducting material is related to its length (l), and cross-sectional area (A) by

$$R = \rho \frac{l}{A} \tag{1}$$

Ohm's law relates the electric current I, potential difference V and resistance R together

$$V = IR$$

$$R = \frac{\Delta V}{I}$$

Combining (1) and (2)

$$\frac{\Delta V}{I} = \rho \frac{l}{A}$$

$$\rho = \frac{\Delta V \cdot A}{I \cdot l} \tag{4}$$

$\rho$  = Resistivity

Equation (4) can be used to determine the resistivity of any homogeneous or isotropic medium provided the geometry is simple.

For a semi-infinite medium the resistivity at every point must be defined if A and l is of infinitesimal size then

$$\rho = \frac{\lim_{l \rightarrow 0} \frac{\Delta V}{I}}{\lim_{A \rightarrow 0} \frac{I}{A}}$$

$$\rho = \frac{E}{J}$$

$$J = \sigma E$$

Where E = electric field, J = current density and

(5)

Since  $\rho = \frac{1}{\sigma}$ ,  $\sigma$  is called the conductivity

For a uniform half-space solution, we consider a single current electrode, a point source of current, on the surface of a homogeneous, isotropic half space, injecting current I into the earth. The circuit is completed by a current sink at a large distance from the electrode. The flow of electric current is radially symmetric in the half space. Because of the radial symmetry, the current density (J) will be constant at a distance r, from the current electrode; the total current flow across the hemispherical surface is given as

$$I = \int_{\text{hemisphere}} J \cdot ds = 2\pi r r^2 J \tag{6}$$

ds = Surface element

Since the current is always normal to the hemisphere, the integration is simply the surface area of the sphere times the (constant) current density. So, we have at any distance r, the current density is

$$J = \frac{I}{2\pi r^2} \tag{7}$$

Equating (5) and (7) and rearranging

$$E = \frac{\rho I}{2\pi r} \tag{8}$$

The potential at a distance R is obtained on integration of (8) from infinity to R

$$V_R = \int_{\infty}^R E \cdot dr = - \int_{\infty}^R \frac{\rho I}{2\pi r^2} dr$$

$$= \frac{\rho I}{2\pi r} \Big|_{\infty}^R$$

$$V_R = - \frac{\rho I}{2\pi R} \tag{9}$$

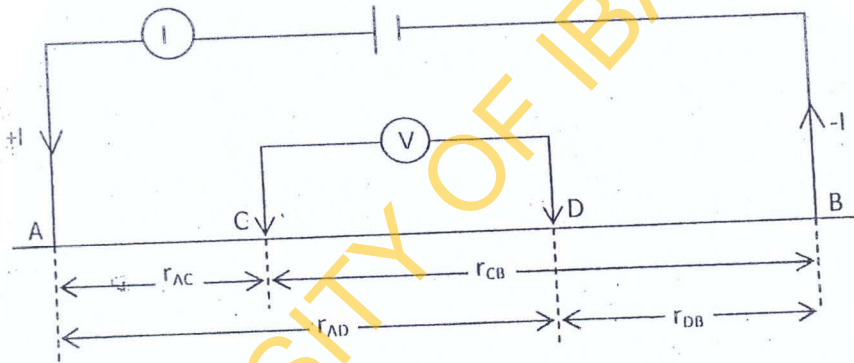

Fig.2: General four electrode array. A and B are current electrodes and D are potential electrodes. The potential due to source A is

$$V_A = + \frac{\rho I}{2\pi r_{AC}}$$

while the potential due to the sink B is

$$V_B = - \frac{\rho I}{2\pi r_{CB}}$$

∴ The potential V<sub>C</sub> at an internal electrode C is the sum of the potential contributions V<sub>A</sub> and V<sub>B</sub> from the current source at A and the sink at B.

$$V_C = V_A + V_B$$



$$V_C = \frac{\rho I}{2\pi} \left( \frac{1}{r_{AC}} - \frac{1}{r_{CB}} \right)$$

Similarly, the resultant potential at D is

$$V_D = \frac{\rho I}{2\pi} \left( \frac{1}{r_{AD}} - \frac{1}{r_{DB}} \right)$$

Absolute potentials are difficult to monitor so the potential difference  $\Delta V$  measured by a terrameter connected between electrodes C and D is

$$\begin{aligned} \Delta V &= V_C - V_D \\ &= \left[ \frac{\rho I}{2\pi} \left( \frac{1}{r_{AC}} - \frac{1}{r_{CB}} \right) \right] - \left[ \frac{\rho I}{2\pi} \left( \frac{1}{r_{AD}} - \frac{1}{r_{DB}} \right) \right] \\ &= \frac{\rho I}{2\pi} \left[ \left( \frac{1}{r_{AC}} - \frac{1}{r_{CB}} \right) - \left( \frac{1}{r_{AD}} - \frac{1}{r_{DB}} \right) \right] \\ &= \frac{\rho I}{2\pi} \cdot \frac{1}{K} \end{aligned} \tag{10}$$

K is called geometric factor of the electrode configuration.

$$K = \left[ \left( \frac{1}{r_{AC}} - \frac{1}{r_{CB}} \right) - \left( \frac{1}{r_{AD}} - \frac{1}{r_{DB}} \right) \right] \tag{11}$$

From (10)

$$\rho = \frac{2\pi \Delta V \cdot K}{I} \tag{12}$$

Given a measurement of  $\Delta V$ , (12) would correctly yield the true resistivity of a homogeneous, isotropic half space. But in practice the earth is not a homogeneous, isotropic half space so (12) becomes the apparent resistivity  $\rho_a$ .

$$\rho_a = \frac{2\pi \Delta V \cdot K}{I} \tag{13}$$

It is basically a way of normalizing away the geometry and current magnitude for the electrical measurement.

The Schlumberger array is used in this study. The spacing between potential electrodes is very much smaller than the current electrode spacing.

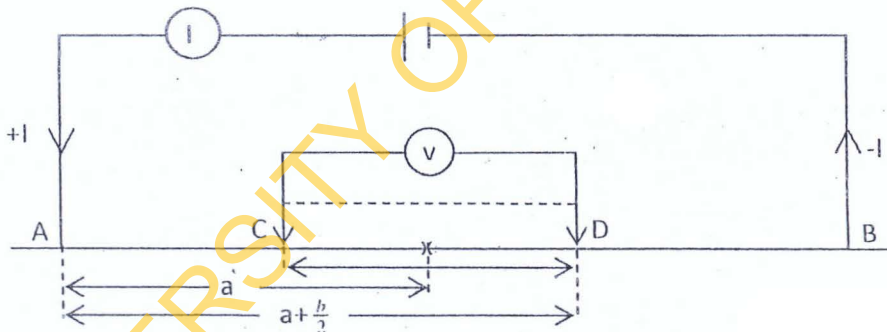

Fig.3: Schlumberger configuration.

In Schlumberger configuration, the mid-point of the array is kept fixed while the distance between the current electrodes is progressively increased. This causes the current lines to penetrate to ever greater depths, depending on the vertical distribution of conductivity.

In this array, the potential and current pairs of electrode also have a common mid-point but the distance between adjacent electrodes differs. It is the most widely used because its time saving requires less manpower. From the diagram

- a = separation between current electrode and mid-point
- b = separation between potential electrodes

Thus,

$$r_{AD} = r_{BC} = a + \frac{b}{2} \text{ and } r_{AC} = r_{BD} = a - \frac{b}{2}$$

The apparent resistivity value ( $\rho_a$ ) therefore becomes

$$\rho_a = R \cdot \frac{\pi a^2}{b} \left( 1 - \frac{b^2}{4a^2} \right); \quad a > 5b$$

$$\frac{\Delta V}{I} = \frac{\pi a^2}{b} \left[ 1 - \frac{b^2}{4a^2} \right] \quad (14)$$

Where  $a > 5b$

The data interpretation techniques involve seeking a solution from Laplace's equation because of the electrical potential considered due to a single current source. That is

$$\nabla^2 V = 0, r = 0$$

Where  $\nabla^2$  is the Laplacian operator which can be expanded in spherical polar coordinates as

$$\nabla^2 V = \frac{1}{r^2} \frac{\partial}{\partial r} \left( r^2 \frac{\partial V}{\partial r} \right) + \frac{1}{r^2 \sin \theta} \frac{\partial}{\partial \theta} \left( \sin \theta \frac{\partial V}{\partial \theta} \right) + \frac{1}{r^2 \sin^2 \theta} \frac{\partial^2 V}{\partial \phi^2} = 0 \quad (15)$$

Equation (15) defines electric potential V as a function of radial distance r.

Laplace's equation is used in interpreting apparent resistivity measurements in terms of lithology variation with penetration depths.

### METHODOLOGY

In this study electrical resistivity method was adopted. The survey covers all the four (4) sides of the dump site. A total of five (5) vertical electrical sounding (VES) points using Schlumberger electrode configuration was carried out at a minimum distance of 27.20m away from the wall of each side of the dump site. The fifth VES point was taken at Glory Tower Schools (N 07° 18' 58.4" E 003° 59' 47.7"), a distance of 3000.0m away from the dump site to serve as a control point. The electrodes were expanded from a minimum current electrode spacing (AB/2) of 1.0m to a maximum of 75.0m covering a total distance of 150.0m. The locations of each VES point as well as each traverse line were recorded with the aid of Global Positioning System (GPS) meter. ABEM SAS 1000 resistivity meter model 2115A was used to acquire data in all the VES points. The field apparent resistivity data were plotted against electrode spacing (AB/2) on a bi-logarithmic coordinates transparent paper. The best smooth curve through the points were interpreted using partial curve matching involving two layer master curves and the appropriate auxiliary charts. The layered model obtained serve as input into computer as initial models and subjected to repeated iterations until a satisfactory fit to the field data was obtained.

### RESULTS AND DISCUSSION

The interpretation of the resistivity curves (Figures 1- 4) of the study dump site show low resistivity values (Side A,  $\rho = 22.3\Omega m$ ; Side B,  $\rho = 31.8\Omega m$ ; Side C,  $\rho = 38.9\Omega m$  and Side D,  $\rho = 34.7\Omega m$ ) compared with the resistivity value of the control point ( Glory Tower Schools,  $\rho = 60.6\Omega m$  ).The low resistivity values around the dump site is an indication of pollution as reported by [11] Leachate from the open dumps usually contain biological and chemical constituents. Organic matter decomposing under aerobic conditions produces carbon dioxide which reacts with the leaching water to form carbonic acid.

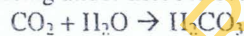

This in turn acts upon metals in the refuse and other calcareous material in the soils and rocks resulting in increasing hardness and conductivity of contaminated water as found in this work and reported by [12]. The resistivity value of the control area is higher suspected to be an aquifer potential for groundwater which shows the probable lithology to be weathered basement.

The breakdown of excess organic matters in waste dumps does not only consume energy but also release a variety of compounds into the groundwater. Older dumps such as those under studied generate leachate plumes which travel kilometers in more permeable environment [8]. To confirm this, groundwater samples were collected from two wells within the vicinity and a well of about 3000.0m far away from the dump site and are analyzed in the laboratory. The results are presented in Table 1. The results of the water analysis were compared with the World Health Organization (WHO) standard for drinking water as presented in Table 1. From the results of table 1, the conductivity is high confirming the results obtained from the geophysical sounding. The high conductivity is an indication of the presence of electrolytes and picture of the concentration of ions in solution. The result of groundwater analysis also confirm the presence of cations ( $Ca^{2+}$ ,  $Mg^{2+}$ ,  $Pb^{2+}$ ,  $Fe^{2+}$ ,  $Zn^{2+}$ ,  $Ni^{2+}$  and  $Na^+$ ). The water is slightly acidic since the pH range is between 5.10 and 6.30 confirming the presence of Leachate.



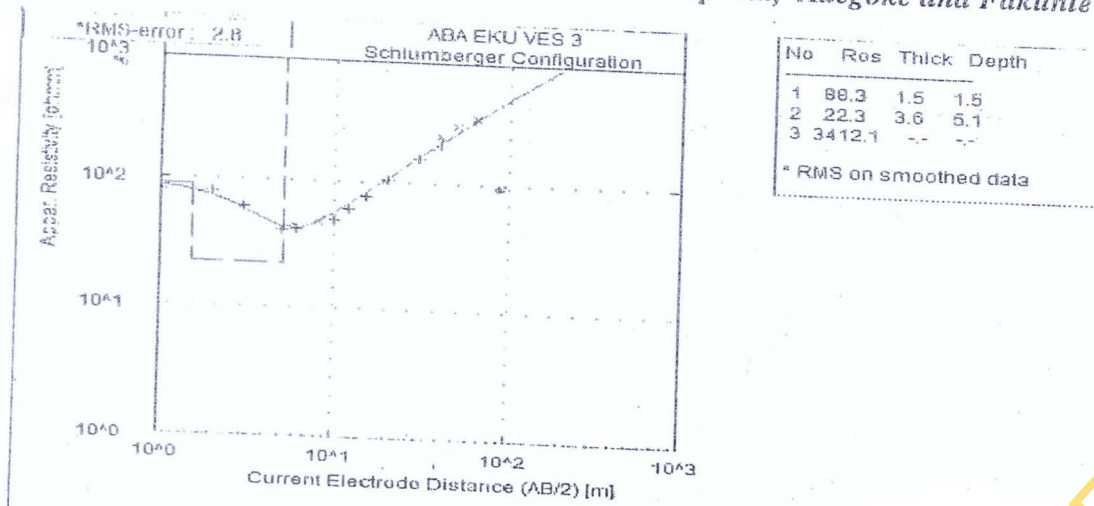

Fig.4: Layer model Interpretation of VES point of side A of Aba- Eku dump site

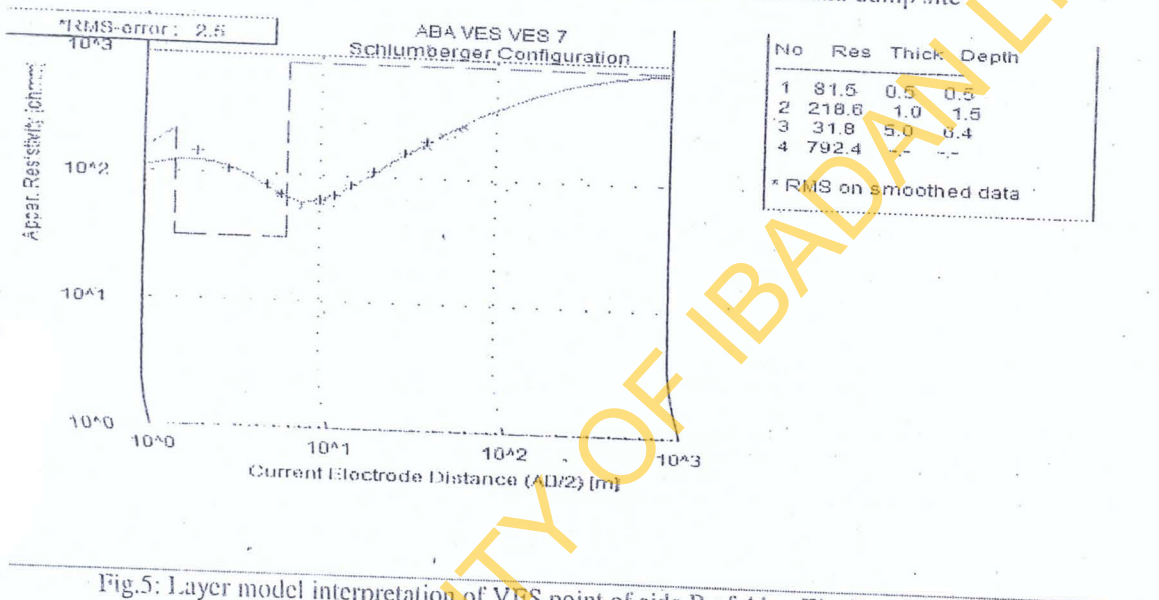

Fig.5: Layer model interpretation of VES point of side B of Aba- Eku Dump Site

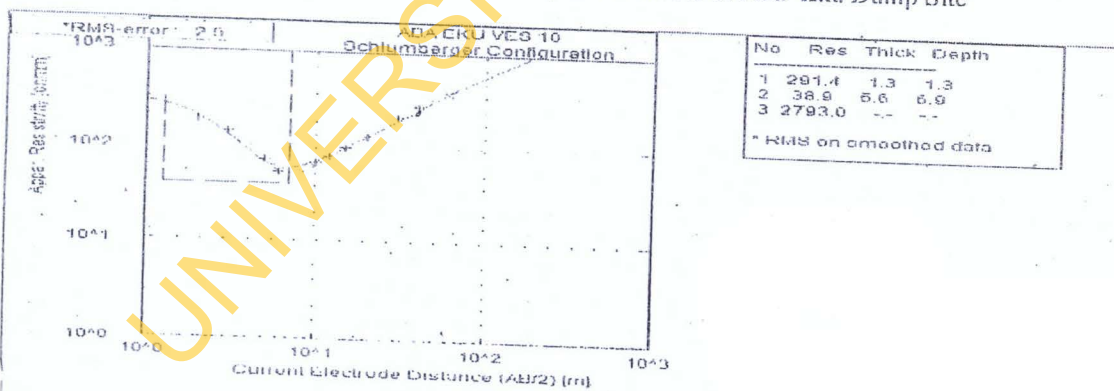

Fig.6: Layer model interpretation of VES point of side C of Aba Eku dump site

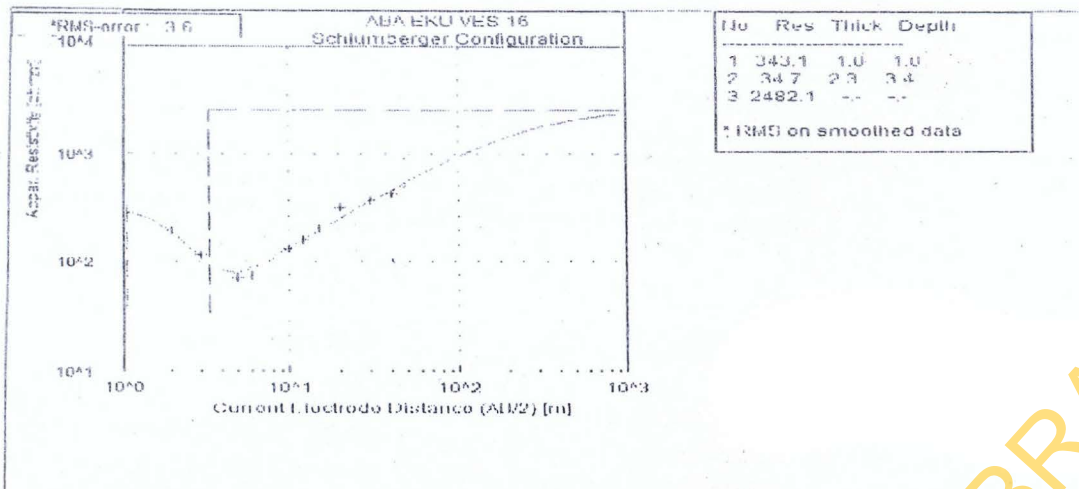

Fig.7: Layer model interpretation of VES point of side D of Aba- Eku Dump site

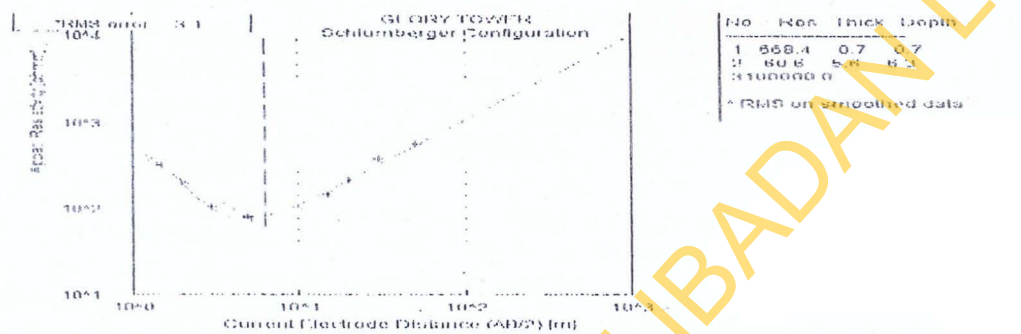

Fig.8: Layer model interpretation of VES point of Glory Tower Schools control point to Aba Eku dump site.

Table 1: The results of the sampled wells for Aba-Eku dump site and control point.

Parameter	ABW <sub>1</sub>	ABW <sub>2</sub>	ABW <sub>c</sub>	WHO Standard
pH	6.20	6.30	6.00	6.5 - 8.5
Alkalinity (Mg/L)	33.00	41.40	210.00	-
Conductivity (µS/cm)	140.00	130.00	487.00	-
Total Hardness (mgCaCO <sub>3</sub> /L)	25.00	29.50	136.00	-
Calcium (mg/L)	6.27	9.55	34.40	-
Magnesium (mg/L)	2.19	4.10	19.60	-
TS	410.00	330.00	580.00	-
TSS	350.00	279.00	310.00	-
COD	97.00	92.00	110.00	-
BOD	2.11	2.34	2.63	-
DO	4.78	5.17	4.22	-
Lead (mg/L)	0.03	0.07	0.05	0.01
Iron (mg/L)	0.51	0.43	0.47	0.00
Zinc (mg/L)	3.44	4.12	3.70	-
Nickel (mg/L)	0.02	0.01	0.02	0.02
Sodium (mg/L)	11.20	10.00	2.31	-



## Conclusions

Geophysical resistivity sounding method has enabled us to detect contaminated groundwater within the studied environment. The hydro chemical analyses isolated main contaminants, which are basically metallic ions. The presence of these metallic ions justifies the low resistivity obtained in the vicinity of the refuse dump sites which was as a result of leachate contamination. The leachate has migrated to depths of 3.4m to 6.9m. The low pH values of the three (3) wells samples are an indication that the groundwater is slightly acidic. The acidity of the groundwater is traceable to the chemical reaction from chemical activities in the dump site. It also implies that leachate has seeped away from the dump sites.

## References

- [1] Abdul Nasir, S.S; Loke, M.H ; Lee, C.Y ; Nawawi, M.N.M: 2000. Salt water intrusion mapping by geo-electrical imaging surveys. *Geophys. Prospect*, 48:647-661
- [2] Adepelumi, A.A; Ako, B.D; Ajayi, T.R; Afolabi, O; Omotoso, E.J. 2008. Delimitation of salt Water Intrusion into the freshwater water Aquifer of Lekki- peninsula, Lagos, Nigeria. *Environ. Geol.* 56 : 927-933.
- [3] Anderson, J.R; and Dornbush J.N; 1967. Influence of sanitary landfill on ground water quality. *Am. Water Works Assoc. Jour.* 457-470 .
- [4] Barker, R. D. 1990. Improving the quality of Resistivity sounding Data in Landfill studies In Ward S.H. (ed.) *Geotechnical and Environmental Geophysics Vol. 2. Environmental and Groundwater* Tulsa. Society of Exploration Geophysicist 245-251.
- [5] Cariera, C and Masciopinto, C. 1998. Assessment of Groundwater After Leachate Release from Landfills. *Annali di Chimica*. 88; 811-818.
- [6] Fatta, D. Papadopoulos, A and Loizidou, M. 1999. A study on the Landfill Leachate and its Impact on the Groundwater Quality of the Greater Area. *Environ. Geochem. Health*. 21:175-190.
- [7] Ikem, A ; Osibanjo, O ; Shridhar, M.K.C; and Sobande, A. 2002. Evaluation of Groundwater Quality Characteristics Near two Waste Sites in Ibadan and Lagos, Nigeria. *Water, Air, and Soil Pollution* 140 :307 - 333.
- [8] Moody, D.W. 1996. Water Quality and Waste Management sources and extent of Groundwater Contamination, North Carolina, Co-operation Extension service publication No Ag - 441:1.
- [9] Nigeria Geological Survey. 1999. Map of Ibadan 1:2000000 scales. Federal Ministry of Mines and power, Nigeria. 1999.
- [10] Rahaman, M.A. 1989. Review of Basement Geology of South-Western Nigeria In: *Geology of Nigeria 2<sup>nd</sup> revised edition* edited by Kogbe, C.A.
- [11] Reynolds, J.M 1997. *An introduction to Applied and Environmental Geophysics* John Willey & sons New York: 796.
- [12] Schneider, W.A. 1978. *Generalized Regional Geology of Nigeria with Emphasis on Nigeria Delta and MPN offshore License Terms*. MPN XR-307:57-70
- [13] Sheaffer, J.R, von Boehm, B and Hackett J.E. 1963. Refuse disposal needs and practices in northeastern Illinois Chicago, Ill Northeastern Illinois Metropolitan Area planning Comm. Tech. Rept. 3:72.
- [14] World Bank. 2000a, Nigeria- Community Based urban Development project NGPE 69901; The world bank, 1818H street NW. Washington D.C. 20433.
- [15] World Bank. 2000b. *World Development Indications 2000*, The World Bank 1818H Street NW Washington DC. 20433.