

**ANALYSIS OF TRAFFIC FLOW ON SELECTED
TWO-LANE HIGHWAYS IN IBADAN METROPOLIS**

BY

FOLAKE OLUBUNMI AKINTAYO

B.Sc. (Hons.) Civil Engineering (Lagos), M.Sc. Industrial Engineering (Ibadan)

**A Thesis in the Department of Civil Engineering
Submitted to the Faculty of Technology
in partial fulfilment of the requirements for the Degree of**

DOCTOR OF PHILOSOPHY

of the

UNIVERSITY OF IBADAN

SEPTEMBER 2011

CERTIFICATION

I certify that this work was carried out by Folake Olubunmi Akintayo in the Department of Civil Engineering, University of Ibadan, Nigeria.

Supervisor
Professor Oluwole A. Agbede
B.Sc., M.Sc. (Ife), Ph.D. (London)
Department of Civil Engineering, University of Ibadan, Nigeria

DEDICATION

This work is dedicated to the:

Glory of God;

Memories of my late father, Mr. Thomas Adebayo Eludipo;
and Prof. Olusegun Adebisi.

ACKNOWLEDGEMENTS

I bless the Almighty God for the successful completion of this work. It started as a dream in 1975 as a beginner in Christ's School, Ado-Ekiti. After a span of over three decades in many spheres of life, God brought the dream to a fulfilment in due season. Many people were used to achieve this dream, some have gone to the great beyond but many are still alive. To the living (Mamas, uncles, aunties, and mentors) many of whom may not be aware of their positive influences in this African girl-child, I say thank you.

I wish to express my heartfelt appreciation to my Supervisor, Prof. O.A. Agbede who was (and still) readily available to show me the goodly and godly way to success. I commend his intervention in my admission for this programme; the story would have been a different one but for his pastoral and fatherly roles. God bless you and your family sir.

The useful contributions of my Heads of Department (Dr. B.I.O. Dahunsi, Prof. A.O. Coker, Dr G.A. Alade, Prof. O.A. Agbede and Dr. S.O. Franklin) at different times in the course of this programme are appreciated. I valued the criticism of the work by Dr. K. A. Falade (Sub-Dean Postgraduate of the Faculty of Technology), Dr. G. M. Ayinuola and Dr. F.A. Olutoge, the present and immediate past Postgraduate Coordinator of the Department respectively. I thank Dr. W. K. Kupolati and Dr. Adewumi (Department of Civil Engineering, Obafemi Awolowo University, Ile-Ife) for their sustained interest in the work. I appreciate the concern and support of Prof. Oluwoye of Alabama A&M University, Alabama, USA. The contributions of other lecturers in the Department: Arc. Eugenious Adebamowo, Engrs. W. O. Ajagbe, Oluyemisi Oladejo and Omolara Lade; fellow PG students, Dr. Muhammed, Engr. Lekan Shittu, LAUTECH friends and others too numerous to mention) helped to sharpen my focus and get the work done, thank you sir/ma.

I also appreciate the combined positive efforts of the technical staff: Messrs. F. A. Ilugbo, G. N. Okerefor, O. S. Ojo, Oghenejakpor, Oyeleke, Akinyemi, Mrs. Funmi Okoji and Tope Ayodele. I am grateful for the unflinching support and the assistance rendered by the administrative staff: Mrs. Tinuke Muritala, Mrs. Veronica Akpokodje, Mrs. Margaret Olaibi, Mr. Ayobami Olajide and our retirees – Messrs Adeleke and Owolabi. I thank the former departmental library assistant, Mr. D. O. Olaibi for his assistance.

I appreciate the good foundations I received for this work from my lecturers in the Department of Civil Engineering, University of Lagos. I am also grateful to my

lecturers in the Department of Industrial and Production Engineering, University of Ibadan in particular Prof. A.O. Oluleye, Prof. O.E. Charles-Owaba, Dr. F.A. Oyawale, Dr. O.G. Akanbi, Mr. S. O. Oladeji and Prof. A. F. Akinbinu (of blessed memory).

I thank Dr. A.O. Owolabi of the Department of Civil Engineering, Federal University of Technology, Akure (FUTA) and bless God for the memory of the late Prof. Olusegun Adebisi. Their joint paper, “Mathematical models for headways in traffic streams” provided an impetus to carry out further research in this area.

I am grateful to friends in my former place of work (University of Agriculture, Abeokuta (UNAAB)) for their encouragement to complete this work. I found the various pieces of advice given by my former Dean, Prof. Ayedun and the incumbent Dean, Prof. Ajisegiri during staff seminars very useful in finalising this work. I also appreciate the concern of my Head of Department in UNAAB, Dr. O.S. Awokola, lecturers, staff and students of the Department of Civil Engineering; lecturers, colleagues and friends from other Departments in the College of Engineering. God bless you all.

The assistance rendered by Messrs Rotimi and Kazeem in the data collection effort for this work is commendable and appreciated. I appreciate the effort of one of my students, Mr. Seyi Mapaderun in the survey works. I say a big thank you to Dr. Sanya Olubusoye (Statistics Department), in getting suitable statistical software for the analysis of the data. I am grateful to Dr. Tunde Akinkunmi (Computer Science Department) for granting me audience whenever I called upon him. I express my heartfelt gratitude to Dr. Roberts of the Computer Science Department and two of his students (Sina and Leke) who assisted in coding ‘Traffic Flow Simulator’.

To members of my families, no word can adequately express my heartfelt appreciation for your understanding and supports all through. You understood the need for me to ‘hibernate’ and get this work completed. I appreciate the spiritual support from my Fathers-in- Lord and Mothers-in Israel. Thank you, Aanuoluwapo for your concern and prayer. I pray God will grant you and my other ‘kids’ the power to surpass this feat in Jesus’ name (amen).

To my beloved husband and friend JOA, it is our success. We went through the narrow path to this success together. *Vielen Dank zu lieben.*

“To God be the glory
Great things He has done”.

ABSTRACT

Traffic congestion is a common feature on highways in many cities of the world, including Ibadan, Nigeria. Previous studies have shown that several mathematical traffic flow models developed to analyse congestion cannot be easily generalised or adapted to varying situations. In addition, validation errors of some models are as high as 60.0 %. In pursuit of the objective of minimising traffic congestion in parts of the Ibadan metropolis, headway simulation models were developed for the analysis of flow on some selected two-lane highways characterised by heavy traffic.

Traffic survey was conducted on three purposively selected heavily-trafficked two-lane highways (Total Garden-Agodi Gate, J Allen-Oke Bola and Odo Ona-Apata) in the Ibadan metropolis. Headway modelling approach incorporating the prevailing roadway, traffic and control conditions was developed. Field data were captured on the three roads with a camcorder between 7.00 a.m. and 6.00 p.m. for a period of six months as specified in the Highway Capacity Manual. Comparison of the modelling result and field headway data were carried out using Kolmogorov-Smirnov (KS) test ($p = 0.05$). A traffic flow simulator was developed to simulate the different congestion scenarios by varying the minimum and maximum headways. Capacity analysis and validation of the results were carried out using ANOVA methods.

Average vehicular flow of 715 ± 3 , 970 ± 5 and 1118 ± 9 vph per lane on Total Garden-Agodi Gate, J Allen-Oke Bola and Odo Ona-Apata roads respectively. Eighteen hyperbolic headway scenarios were produced and the highest coefficient of correlation ($R^2 = 0.92$) was recorded at 90 percentile while 0.18, 0.36, 0.50, 0.71, 0.82, and 0.79 were obtained at 1, 10, 30, 50, 70, and 100 percentiles respectively. There was no significant difference between theoretical and field data using Kolmogorov-Smirnov (KS) test ($p < 0.05$). Also, a total number of 171 congestion scenarios were generated using the traffic flow simulator. Traffic flow varied between 204 and 2376 pcu per lane while headways varied between 1 and 18 seconds. The capacity analysis produced approximated maximum flow rates of 1850, 2865 and 2881 pcu in the two directions of travel for Total Garden-Agodi Gate, J Allen-Oke Bola and Odo Ona-Apata roads respectively. The capacity of Total Garden-Agodi Gate was within the recommended maximum value of 2800 pcu in the two directions of travel for two-lane highways. The results for J Allen-Oke Bola and Odo Ona-Apata roads showed that an

additional lane will be required in each direction of travel. The validation of the models on the dualised J Allen-Oke Bola road showed that congestion can be reduced by about 55.0 %. A maximum validation error of 35.0 % was obtained.

The traffic flow simulator developed successfully simulated the traffic situations on the selected highways. The analysis of the flow yielded results that could ameliorate traffic congestion on the selected two-lane highways in the Ibadan metropolis.

Keywords: Traffic flow, Two-lane highways, Headway simulation models, Traffic congestion, Capacity analysis.

Word Count: 469

TABLE OF CONTENTS

	Page
Certification	ii
Dedication	iii
Acknowledgements	iv
Abstract	vi
Table of Contents	viii
List of Figures	xi
List of Plates	xiii
List of Tables	xiv
Notation	xv
Chapter 1	
INTRODUCTION	1
1.1 Background	1
1.2 Research Problem	4
1.3 Study Area	5
1.4 Aim and Objectives	5
1.5 Justification	10
Chapter 2	
LITERATURE REVIEW	
2.1 Traffic Flow	11
2.1.1 Traffic flow parameters	11
2.1.2 Measurement of Traffic Flow	12
2.1.3 Traffic Flow Regimes	12
2.2 Traffic congestion	13
2.2.1 Causes of traffic congestion	13
2.2.2 Negative Impacts of traffic congestion	13
2.2.3 Congestion reduction strategies	14
2.2.4 Analysis of congested flow	16
2.3 Traffic flow modelling	17
2.3.1 Types of models	17
2.3.2 Criteria for model selection	18
2.3.3 Traffic simulation	21
2.3.4 Traffic simulation models	21

	Page	
2.3.5	Classification of traffic simulation models	22
2.3.6	Traffic simulation model building	24
2.3.7	Vehicle generation algorithm	25
2.4	Headway Distribution Models	26
2.4.1	Headway distribution models for free flow	27
2.4.2	Headway distribution models for constrained flow	28
2.4.3	Parameter estimation and calibration of headway models	29
2.5	Highway Capacity	32
2.5.1	Factors affecting capacity	32
2.5.2	Need for highway capacity analysis	34
2.5.3	Capacity analysis methods	35
2.5.3.1	The Highway Capacity Manual method	35
2.5.3.2	The British Standard Approach	36
2.5.3.3	Statistical method	38
2.5.3.4	Dynamic highway capacity estimation method	38
2.5.3.5	Safety-based capacity analysis	38
2.5.4	Level of Service	38
2.5.5	Acceptable degrees of congestion	40
2.5.6	Design hourly volume	41
2.5.7	Capacity of two-lane highways	41
2.5.8	Capacity analysis of two-lane highways	42
Chapter 3		
	METHODOLOGY	44
3.1	Traffic Survey	44
3.2	Traffic Data collection	44
3.2.1	Headway data capturing and extraction	45
3.3	Headway Modelling Process	45
3.3.1	Theoretical headway generation algorithm	45
3.3.2	Hyperbolic headway distribution models	47
3.4	Traffic Flow Simulator (TRAFLOS)	48
3.4.1	TRAFLOS algorithm	48
3.5	Experimental Design of Congestion Scenarios	50
3.6	Practical Capacity of Selected Roads	52

	Page
3.6.1 Determination of adjustment factors	52
3.7 Statistical Analysis	53
Chapter 4	
RESULTS AND DISCUSSIONS	55
4.1 Traffic Survey Results	55
4.1.1 General summary	55
4.1.2 Average traffic flow	57
4.1.3 Field headways	58
4.2 Headway Modelling Output	61
4.2.1 Vehicular interaction	61
4.2.2 Comparison of theoretical and field headways	67
4.3 Traffic Flow Analysis	68
4.3.1 Simulated traffic flows	68
4.3.2 Congestion factors	72
4.3.3 Capacity adjustment	75
4.3.4 Capacity analysis for different congestion scenarios	75
4.3.5 Results of the analysis of variance test	82
4.3.6 Validation of models for J Allen Oke-Bola road	83
4.3.7 Validation errors	84
Chapter 5	
CONCLUSION AND RECOMMENDATION	85
5.1 Conclusions	85
5.2 Recommendation	85
REFERENCES	86
APPENDICES	96
Appendix A1: SONY camcorder operating guide	97
Appendix A2: Extracted field headway data set	105
Appendix B: Headway modelling output	112
Appendix C: Kolmogorov-Smirnov test	135
Appendix D: Traffic flow simulator output	150
Appendix E: One-way ANOVA test	192

LIST OF FIGURES

	Page
Fig. 1.1: Nigeria's road network	6
Fig. 1.2: Ibadan metropolitan area's road network	7
Fig. 1.3: Network of some principal roads in Ibadan metropolis	8
Fig. 2.1: Model usage flow chart	19
Fig. 3.1: Theoretical headway generation algorithm flowchart	46
Fig. 3.2: Traffic flow simulator flowchart	49
Fig. 4.1: Distribution of field headways for flows between 700 to 1200vph	60
Fig. 4.2: Cumulative headway distribution for flows between 700 to 1200vph	66
Fig. 4.3: Distribution of simulated flows with minimum headway of 1 second	71
Fig. 4.4: Congestion factors for simulated flows	74
Fig. B2.1: Hyperbolic model at 1 percentile vehicular interaction	117
Fig. B2.2: Hyperbolic model at 2 percentile vehicular interaction	118
Fig. B2.3: Hyperbolic model at 3 percentile vehicular interaction	119
Fig. B2.4: Hyperbolic model at 4 percentile vehicular interaction	120
Fig. B2.5: Hyperbolic model at 5 percentile vehicular interaction	121
Fig. B2.6: Hyperbolic model at 10 percentile vehicular interaction	122
Fig. B2.7: Hyperbolic model at 20 percentile vehicular interaction	123
Fig. B2.8: Hyperbolic model at 30 percentile vehicular interaction	124
Fig. B2.9: Hyperbolic model at 40 percentile vehicular interaction	125
Fig. B2.10: Hyperbolic model at 50 percentile vehicular interaction	126
Fig. B2.11: Hyperbolic model at 60 percentile vehicular interaction	127
Fig. B2.12: Hyperbolic model at 70 percentile vehicular interaction	128
Fig. B2.13: Hyperbolic model at 80 percentile vehicular interaction	129
Fig. B2.14: Hyperbolic model at 90 percentile vehicular interaction	129
Fig. B2.15: Hyperbolic model at 95 percentile vehicular interaction	130
Fig. B2.16: Hyperbolic model at 98 percentile vehicular interaction	131
Fig. B2.17: Hyperbolic model at 99 percentile vehicular interaction	132
Fig. B2.18: Hyperbolic model at 100 percentile vehicular interaction	133

	Page
Fig. C1.1: Comparison of field and simulated headways for flow rate of 700 vph	145
Fig. C1.2: Comparison of field and simulated headways for flow rate of 800 vph	146
Fig. C1.3: Comparison of field and simulated headways for flow rate of 900 vph	147
Fig. C1.4: Comparison of field and simulated headways for flow rate of 1000 vph	148
Fig. C1.5: Comparison of field and simulated headways for flow rate of 1100 vph	149

LIST OF PLATES

	Page
Plate 1.1: Traffic stream on Obafemi Awolowo road(before dualisation)	9
Plate 1.2: Traffic stream on Odo Ona-Apata road	9
Plate 3.1: Sony HDR-HC3 Camcorder	54
Plate 3.2: Traffic Flow Simulator screen	55

LIST OF TABLES

	Page
Table 2.1: Overview of traffic flow models	20
Table 2.2: Comparison of headway distribution models	30
Table 2.3: Recommended design flows for two-way urban roads	37
Table 2.4: Level of service characteristics	39
Table 2.5: Guide for selection of design levels of service	41
Table 2.6: Maximum service volumes under ideal conditions	43
Table 3.1: Congestion scenarios design template	51
Table 4.1: Summary of preliminary traffic study	56
Table 4.2: Average traffic flow on selected roads	57
Table 4.3: Minimum and maximum values of headway	58
Table 4.4: Percentage composition of field headway per flow regime	59
Table 4.5: Hyperbolic headway simulation models	62
Table 4.6: Hyperbolic model adjustment factors	63
Table 4.7: Cumulative headway distribution spreadsheet for flows between 700 to 1200 vph	64
Table 4.8: Kolmogorov-Smirnov test result	67
Table 4.9: Simulated traffic volume for different congestion scenarios	69
Table 4.10: Computed flow rates for different congestion scenarios	70
Table 4.11: Computed congestion factors for different congestion scenarios	73
Table 4.12: Congestion factors and equivalent level of service	74
Table 4.13: Capacity adjustment factors	75
Table 4.14: Capacity analysis of Total Garden-Agodi Gate road for $k_c=1$	76
Table 4.15: Capacity analysis of J Allen-Oke Bola road for $k_c=1$	77
Table 4.16: Capacity analysis of Odo Ona-Apata road for $k_c=1$	78
Table 4.17: Simulated capacities at different congestion levels for Total Garden-Agodi Gate road	79
Table 4.18: Simulated capacities at different congestion levels for J Allen-Oke Bola road	80
Table 4.19: Simulated capacities at different congestion levels for Odo Ona-Apata road	81
Table 4.20: ANOVA test result for field and simulated capacities	82
Table 4.21: Capacity adjustment factors for dualised J Allen-Oke Bola road	83
Table 4.22: Capacity analysis of dualised J Allen-Oke Bola Road	84

NOTATION

A	=	cumulative headway adjustment factor
C	=	basic capacity
C_p	=	practical capacity
e_i	=	lower boundary limit of headways in G_i
d_i	=	upper boundary limit of headways in G_i
$f(x)$	=	probability density function of x
f_i	=	adjustment factor
G_i	=	headway group i
h	=	headway
h_1	=	minimum headway
h_2	=	maximum headway
H	=	cumulative headway
k	=	traffic density
k_c	=	congestion factor
k_i	=	headway group composition factor i
q	=	flow (vehicles arrival rate)
R_n	=	random number
R^2	=	coefficient of correlation
T	=	total time/total headway
v	=	mean (average) speed
V	=	traffic volume
V_R	=	number of vehicles released per simulation run

Chapter 1

INTRODUCTION

1.1 Background

The highway network is an important component of the transportation system. In Nigeria, it is the principal means of transportation facilitating the socioeconomic activities of the people. Two-lane highways (single carriageway) formed the main component of this system at the local, state and federal levels. Efficient and effective flow of traffic is desirable for the highway system to operate optimally at designed capacity and for favourable level of service.

Traffic flow represents the interaction between vehicles, drivers and infrastructure. Traffic flow can be either free or constrained (Helbing, 2001; and Nagatani, 2002). In free flow conditions, drivers can choose their own speed or constrained to car-following system. Kerner (2004) classified the congestion regime into two distinct phases: synchronized flow and wide moving jams. In synchronized flow, the speeds of the vehicles are low and vary quite a lot between vehicles, but the traffic flow remains close to free flow. In wide moving jams, vehicle speeds are more equal and lower, and time delays can be quite large. Traffic congestion is a road condition characterised by speeds slower than free flow speeds, resulting in longer travel times and increased queuing (Aworemi *et al.*, 2009; Hook 1995). It occurs when traffic demand is greater than the capacity of a road (Lee *et al.*, 2008). Traffic jam is extreme traffic congestion where vehicles are fully stopped for periods of time (Abul-Magd, 2007).

Traffic congestion is considered one of the main urban transportation problems, particularly in developing countries where vehicle ownership is growing geometrically without corresponding sustainable land use patterns and transportation schemes (Tugbobo, 2009). Traffic congestion leads to increased travel time, air pollution and fuel consumption. Providing additional lanes to existing highways and building new ones have been the traditional response to congestion (FHW 2005). However, the data collection effort for this exercise is great. Consequently, transportation engineers and researchers are increasingly developing simulation models to analyse traffic flows on highways.

Capacity expansion is one of the strategies usually adopted in both developed and developing countries to mitigate traffic congestion. Expanded highways improve traffic flow and reduce congestion. Capacity is the maximum number of vehicles that can pass a given point on a roadway or in a designated lane during one hour without the traffic density being so great as to cause unreasonable delay, hazard, or restriction to the drivers' freedom to manoeuvre under the prevailing roadway and traffic conditions (TRB, 2000). Major attention has been given to capacity analysis methodology, because capacity estimates have a central role in the estimation of other highway performance measures (Luttinen, 2004). False estimation pollutes other reasonable traffic studies. Errors caused by inaccurate or wrong estimation of highway capacity can easily affect the results of other studies (Hwang *et al.*, 2005).

Zang (2010) developed an improved highway capacity model that is feasible and can reflect the actual traffic flow characteristics; Yao *et al.* (2009) developed optimisation procedure that produced good estimates of the roadway capacity and other traffic stream parameters. Tanyel *et al.* (2005) showed that further studies should be made to develop a more reliable capacity and performance models for Turkey. Chang and Kim (2000) presented a quantitative method for highway capacity determination by evaluating alternative approaches in developing capacity from the statistical distribution of observed headways of traffic flow in Korea. Approximated headway distribution models of free-flowing traffic on Ohio Freeways was developed by Zwahlen *et al.* (2007) to simulate queue buildup and delay times under congested traffic conditions.

Traffic flow is a complex phenomenon and quite difficult to completely understand. Over the last fifty years, several modelling methods have been developed for vehicular traffic flow and categorised based on applicability, generability and accuracy (Hoogendoorn and Bovy, 2001). Lu (1990) also emphasised the importance of the accuracy of models for traffic flow simulation. Brockfield *et al.* (2004) reported that the most difficult stage in the development and use of traffic flow models is the calibration and validation stage. Validation errors of some models are as high as 60 %. The difficulty is due to lack of suitable methods for adapting the models to empirical data.

Headway modelling is useful in the analysis of flow in a traffic stream (Chandra & Kumar, 2001). Highway capacity is usually determined by the minimum acceptable mean headway (Zhang *et al.*, 2007 and Arasan and Koshy, 2003).

Headway is defined as the time between successive vehicles as they pass a point on a lane (Banks, 2003; Kyte & Teplay, 1999; Owolabi and Adebisi, 1996). It is usually measured in seconds. Headway measurement can be performed manually with a stopwatch and automatically with any presence-type detector or with video image processors (Salter, 1990). Headways are affected by such factors as traffic volume, ratio of large sized vehicles, road structure, daytime or night-time, and weather (Daisuke *et al.*, 1999).

Several studies have been carried out using headway modelling to analyse and solve specific traffic problems on highways (Akintayo and Agbede, 2009); Onibere *et al.* (1987); and Ovuworie (1980). Hoogendoorn (2005) presented a new approach to estimating the distribution of free speeds using a composite time headway distribution model. Haight *et al.* (1961) proposed a new statistical method for describing headway distribution of cars by classifying them as random, regular (equally spaced) or intermediate. Hossain and Iqbal (1999) found that in the flow range of 200-640 vph the exponential and log-normal distributions can best describe the headway pattern on two-lane, two-way highways. Owolabi and Adebisi (1993) found the composite exponential model to be a sound descriptor of observed headways along Zaria-Sokoto Road, Nigeria for flows ranging from 170 vph to 750 vph irrespective of whether or not motorcycles were in the traffic stream. Dawson and Chimini (1968) developed a generalised type headway model for single lane traffic flows on two-lane, single carriageways. Bham and Ancha (2006) proposed two shifted continuous distribution models, the lognormal and gamma models for preferred time headway and time headway of drivers in steady state car-following. Yuichi and Shizuma (1989) presented a practical method for estimating the headway distribution based on the experimentally observed data of the number of vehicles passing in a certain time interval theoretically as a general case of gamma-type headway distribution model.

Parameters of headway distribution models are usually estimated from the field data. The field data must be reliable and the parameters must be properly estimated before the models can be applied. Hagrang (2000) highlighted three techniques usually employed in headway parameters estimation: the method of moments, the maximum-likelihood method and the least-squares method. As highlighted earlier, several researchers have used these techniques to develop simple mathematical models based on Poisson and Erlang distributions to estimate headway parameters for flows at low levels. Complex mathematical headway distribution models such as Log-

normal, Pearson Type III and Hyperlang have been employed in parameter estimation of moderate and high traffic flow levels. However, for cases in which the random traffic-based Poisson does not hold or other mathematical headway distributions require great field measurements or do not fit the real-world data closely, researchers are increasingly developing simulation models to analyse and solve complex flow problems in engineering (Agbede, 1995; Kosonen, 1999). Brockfield *et al.* (2007) reported that simulation models are becoming increasingly important tools in modelling transportation systems. Metcalfe (1997) explained that simulation techniques are useful in complex situations for which appropriate formulae are not known although they are far less convenient than mathematical models. It is also important to apply appropriate and reasonable initial and boundary conditions to the simulation models to ensure reliability of output results (Agbede and Adegbola, 2003)

Lee *et al.* (2008) developed a simulation tool using stand-alone application which adopts object-oriented approach and JAVA as the main application programming interface (API) to forecast traffic congestion level. Zwahlen *et al.* (2007) suggested that it would be advantageous to convert hourly traffic counts into corresponding cumulative headway using the least-squares method. They employed this method to generate hyperbolic fit models to approximate headway distributions of free-flowing traffic on Ohio Freeways for work zone traffic simulations.

1.2 Research Problem

In spite of the global economic recess, vehicle ownership is continuing to increase in cities of the world including Nigeria. The consequences of this in Ibadan metropolis, where there is no corresponding sustainable land use patterns and transportation schemes is traffic congestion. Dynamic traffic data capturing and analysis systems are necessary to assist the civil engineers on the improvement schemes to ameliorate the problem. However, the challenges and cost of these systems are enormous for Oyo State and the eleven Local Government Areas constituting the Ibadan metropolis.

Previous studies have shown that several mathematical traffic flow models developed to analyse congestion cannot be easily generalised or adapted to varying roadway, traffic and control conditions. In addition, validation errors of some models are as high as 60.0 %. In pursuit of the objective of minimising traffic congestion in

parts of the Ibadan metropolis, headway simulation models were developed for the analysis of flow on some selected two-lane highways characterised by heavy traffic.

1.3 Study Area

Nigeria is connected by a network of roads as shown in Fig. 1.1. The two-lane roads form its major component particularly in Oyo State. Ibadan is the capital of Oyo State, one of the thirty-six states in Nigeria. The metropolitan area of Ibadan is approximately on Latitudes $7^{\circ} 15'$ and $7^{\circ} 30'$ North of the Equator; and Longitudes $3^{\circ} 45'$ and $4^{\circ} 00'$ East of the Greenwich Meridian (Ayeni, 2002).

The road network connecting the eleven Local Government Areas in the metropolis (Fig. 1.2) is vast and central to the socioeconomic activities of the people. A network of the roads studied (Total Garden-Agodi Gate, J Allen-Oke Bola and Odo Ona-Apata) and some other principal roads in the metropolis are shown in Fig. 1.3. Two of the roads studied, J Allen-Oke Bola and Odo Ona-Apata are sections of Obafemi Awolowo (formerly Lagos By-pass) and Ibadan-Abeokuta roads respectively. These roads are under the jurisdiction of the federal government. The Odo Ona-Apata road serves as a link to the Nigerian National Petroleum Corporation (NNPC) depot in Ibadan. The road also connects Ibadan to Abeokuta, the Ogun State capital.

The J Allen-Oke Bola is a link road to the Central Business District (CBD) of the metropolis (Dugbe and environs). The third road, Total Garden-Agodi Gate is under the purview of the Oyo State government. It links some areas in the metropolis with the University Teaching Hospital (UCH) and the Oyo State Secretariat.

Traffic streams on J Allen-Oke Bola and Odo Ona-Apata roads are shown in Plates 1.1 and 1.2 respectively.

1.4 Aim and Objectives

The aim of this study is to formulate a rational procedure for minimising highway traffic congestion using germane traffic parameters such as headway and flow.

The objectives of this study are as follows:

- i. To determine the parameters that contribute to congestion of purposively selected roads in Ibadan metropolis.
- ii. To develop models for representing and replicating the parameters.

- iii. To evolve mechanisms for traffic flow enhancement and congestion reduction on the roads under study.

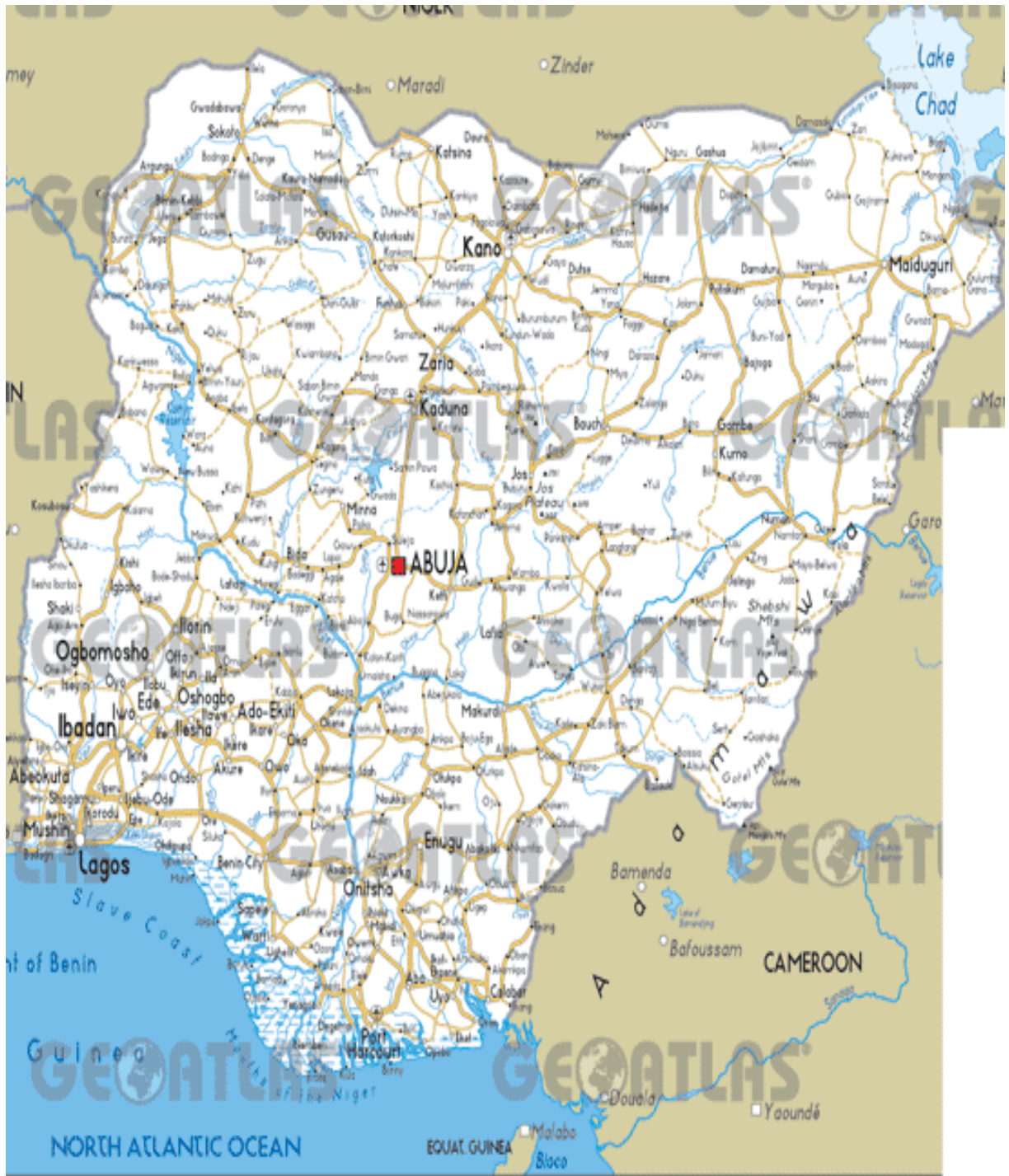

Fig. 1.1. Nigeria's road network
Source: GEOATLAS (2011)

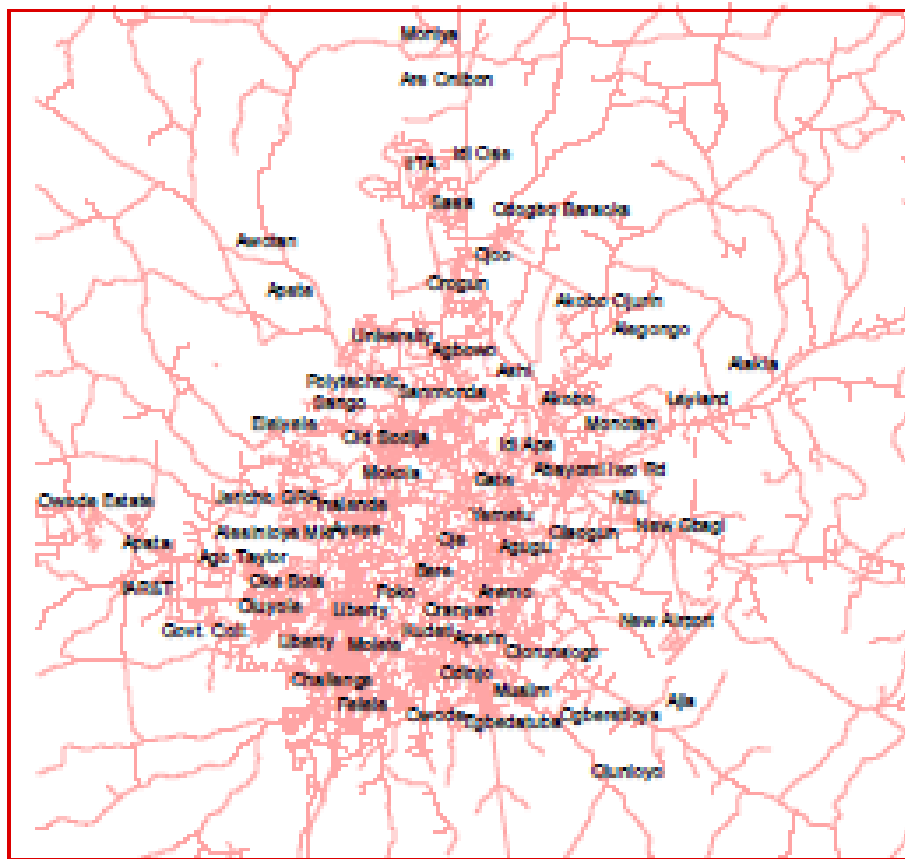

Fig. 1.2. Ibadan metropolitan area's road network
 Source: Ayeni (2002)

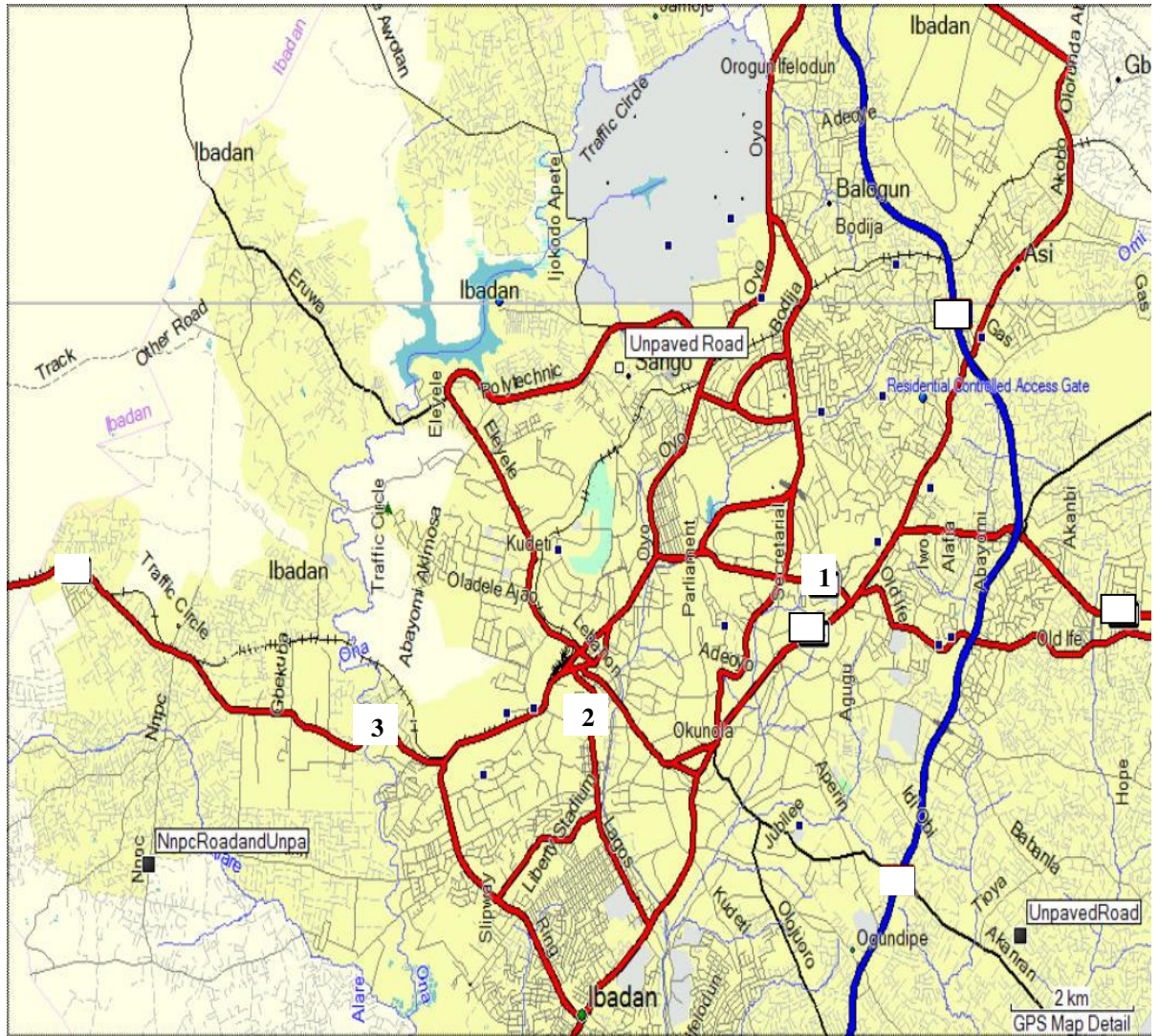

Fig. 1.3. Network of some principal roads in Ibadan metropolis
 Source: Tele Atlas Africa (2007)

- 1** Total Garden-Agodi Gate road
- 2** J Allen-Oke Bola road
- 3** Odo Ona-Apata road



Plate 1.1. Traffic stream on J Allen-Oke Bola road
(14 January, 2009; before dualisation of the road)



Plate 1.2. Traffic stream on Odo Ona-Apata road
(23 April, 2009; 10:12 a.m.)

1.5 Justification

Traffic congestion is a common feature on highways in many cities of the world including Ibadan, Nigeria. Previous studies have shown that several mathematical traffic flow models developed to analyse congestion cannot be easily generalised or adapted to varying situations. In addition, validation errors of some models are as high as 60.0 %. There is therefore a need to formulate a rational procedure for minimising highway traffic congestion using germane traffic parameters such as headway and flow. The mechanisms should be able to enhance traffic flow and reduce congestion on the two-lane highways under study in Ibadan, Nigeria. The system should also be replicable and adaptable for efficient and effective management of other two-lane highways in many cities of the world.

CHAPTER 2

LITERATURE REVIEW

2.1 Traffic Flow

The scientific study of traffic flow had its beginning in the 1930s with the application of probability theory to the description of road traffic (Adams, 1936). However, the evolving discipline now known as traffic flow theory was instigated in the 1950s by the works of many researchers: Wardrop (1952), Pipes (1953), Lighthill and Whitham (1955), Newell (1955), Webster (1957), Edie and Foote (1958) and Chandler *et al.* (1958). With the advent of personal computers, the research and application of traffic flow theory continues: Bagchi and Maarseveen (1980); Cremer and Papageorgiou (1981); Junevicius and Bogdevicius (2009); Arasan and Arkatkar (2010); Mallikarjuna and Rao (2010).

Traffic flow phenomena are associated with a complex dynamic behaviour of spatiotemporal traffic patterns. A spatiotemporal traffic pattern is a distribution of traffic flow variables in space and time. As a result, measurement of the variables of interest for traffic flow theory is in fact the sampling of a random variable (Hall, 1997). Therefore, only through a spatiotemporal analysis of real measured traffic data the understanding of features of real traffic is possible (Kerner, 2009).

Traffic flow theories seek to describe in a precise mathematical way the interactions between the vehicles and their operators and the infrastructure. The inclusion of human factors into road traffic flow modelling equations has further increased the complexity associated with traffic flow analysis (Maerivoet and Moor, 2005); Akanbi *et al.*, 2009). The theories are an indispensable construct for all models and tools that are being used in the design and operation of highways (Gartner *et al.*, 1997).

2.1.1 Traffic Flow Parameters

Traffic flow can generally be described in terms of three parameters: the mean speed v , the traffic flow rate q , and the traffic density k (Payne, 1979; Wu, 2002). The three parameters are associated with each other by the equilibrium relationship:

$$q = vk \tag{2.1}$$

The speed and the density describe the quality of service experienced by the traffic stream while the flow rate (often shortened as flow) measures the quantity of the

stream and the demand on the highway facility (Salter and Hounsell, 1996; May, 2001).

2.1.2 Measurement of Traffic Flow

Measurement at a point, by hand tallies or pneumatic tubes, was the first procedure used for traffic data collection. This method is easily capable of providing volume counts and therefore flow rates directly, and with care can also provide time headways. The technology for making measurements at a point on freeways changed over 30 years ago from using pneumatic tubes placed across the roadway to using point detectors (May et al. 1963; Athol 1965). The most commonly used point detectors are based on inductive loop technology, but other methods in use include microwave, radar, photocells, ultrasonics, and television camera.

Traffic flow rate, often shortened as flow, is simply defined as the number of vehicles passing some designated highway point in a given time interval (Mannering and Kilareski, 1997). It is typically expressed as an hourly rate, that is, in number of vehicles per hour. Flow rates are collected directly through point measurements, and by definition require measurement over time. They cannot be estimated from a single snapshot of a length of road. Flow rates are usually expressed in terms of vehicles per hour, although the actual measurement interval can be much less. Concern has been expressed, however, about the sustainability of high volumes measured over very short intervals (such as 30 seconds or one minute) when investigating high rates of flow. The 1985 Highway Capacity Manual (HCM 1985) suggests using at least 15-minute intervals, although there are also situations in which the detail provided by five minute or one minute data is valuable.

2.1.3 Traffic Flow Regimes

Flow regimes (phases and states) are used to describe operational characteristics of flow in a traffic stream. The regimes are generally classified into two (Colombo, 2002):

1. Free-flow traffic occurs at low densities and as such vehicles are able to freely travel at their desired speed. The traffic flow is unrestricted, that is, no significant delays are introduced due to possible overtaking manoeuvres. The flow is said to be stable since the effects of small and local disturbances in the temporal and spatial patterns of the traffic stream are insignificant.

2. Congested flow is characterized by the decrease in speed, the increase in travel time and the increase of vehicle's queue on the road (Lee *et al.*, 2008). The congested flow may further be classified into two phases based on the empirical findings of Kerner and Rehborn (1996):
 - i. Synchronised flow, also called capacity flow by Maerivoet and Moor (2005). It is characterised by low speed but high continuous flow. In this state, the average headway is minimal and maximum flow is attained.
 - ii. Wide-moving jam describes low speeds and low flows.

2.2 Traffic Congestion

Generally, traffic congestion occurs when traffic demand is greater than the capacity of the road. Traffic congestion is considered to be at extreme level when vehicles are fully stationary for long periods of time (Lee *et al.*, 2008). Traffic congestion can be characterised based on three factors:

- Slower speed of vehicles
- Longer travel times
- Increased queuing

2.2.1 Causes of Traffic Congestion

The US Federal Highway Administration (FHWA, 2005) has classified seven main causes of traffic congestion as:

- physical bottlenecks/ capacity
- traffic incidents
- work zones
- weather
- traffic control devices
- special events and
- fluctuation in normal traffic

2.2.2 Negative impacts of Traffic congestion

Andrew (2004) opined that traffic congestion has a number of negative effects which include:

- i. Wasting time of motorists and passengers ("opportunity cost"). As a non-productive activity for most people, congestion reduces regional economic health.
- ii. Delays, which may result in late arrival for employment, meetings, and education, resulting in lost business, disciplinary action or other personal losses.
- iii. Inability to forecast travel time accurately, leading to drivers allocating more time to travel "just in case", and less time on productive activities.
- iv. Wasted fuel increases air pollution and carbon dioxide emissions (which may contribute to global warming) owing to increased idling, acceleration and braking. Increased fuel use may also in theory cause a rise in fuel costs.
- v. Wear and tear on vehicles as a result of idling in traffic and frequent acceleration and braking, leading to more frequent repairs and replacements.
- vi. Stressed and frustrated motorists, encouraging road rage and reduced health of motorists.
- vii. Emergencies: blocked traffic may interfere with the passage of emergency vehicles travelling to their destinations where they are urgently needed.
- viii. Spill over effect from congested main arteries to secondary roads and side streets as alternative routes are attempted ('rat running'), which may affect neighbourhood amenity and real estate prices.

2.2.3 Congestion reduction strategies

Aworemi *et al.* (2009) came up with the following strategies to ameliorate traffic congestion on Nigerian roads.

- i. Enhanced transport coordination: the various modes of public transport including intermediate public transport have to work in tandem. They should complement rather than involve themselves in cutthroat competition. Therefore there is an urgent need for a transportation system that is seamlessly integrated across all modes in Lagos State. Since the ultimate objective is to provide an adequate and efficient transport system, there is a need to have a coordinating authority with the assigned role of coordinating the operations of various modes (Sanjay, 2005). This coordinating authority may be appointed by the state or federal government and may have representatives from various stakeholders such as private taxi operators, bus operators, railways and the government. The key objective should be to attain the integration of different modes of transport to improve the efficiency of service delivery and comfort for commuters, which in turn can

- dissuade the private car owners from using their vehicles and thereby reducing the number of cars on the roads which can eventually lead to congestion reduction.
- ii. Road Capacity Expansion: road widening is often advocated as ways to reduce traffic congestion. However it tends to be expensive and may provide only modest congestion reduction benefits over the long run, since a significant portion of added capacity is often filled with induced peak period vehicle traffic. A large amount of additional capacity would be needed to reduce urban traffic congestion. Some research indicates that roadway capacity expansion provides only slight reductions in urban traffic congestion (Texas Transportation Institute, 2009).
 - iii. Improved road infrastructure: this include,
 - Junction improvement
 - Grade separation using bridges (or, less often tunnels) freeing movements from having to stop for other crossing movement
 - Reversible lanes, where certain sections of highway operate in the opposite direction on different times of the day or days of the week, to match asymmetric demand. This may be controlled by variable message signs or by movable physical separation.
 - Bus lanes, for example, the Bus Rapid Transit (BRT)
 - Separate lanes for specific user groups (usually with the goal of higher people throughput with fewer vehicles).
 - iv. Supply and demand: congestion can be reduced by either increasing road capacity (supply) or by reducing traffic (demand). Capacity can be increased in a number of ways, but needs to take account of latent demand otherwise it may be used more strongly than anticipated (Hermann, 2006). Increased supply can include, adding more capacity over the whole of a route or at bottlenecks, creating new routes, and traffic management improvements. Reduction of demand can include, parking restriction, park and ride, reduction of road capacity, congestion pricing, road space rationing, and incentives to use public transport, telecommuting, and online shopping.
 - v. Intelligent transportation system: intelligent transportation systems include the application of a wide range of new technologies, including traffic reporting via

radio or possibly mobile phones, parking guidance and information, automated highway systems, traffic counters, navigation systems, transit improvement and electronic charging. These can provide great reduction in congestion as well as variety of transportation improvements. (Ogilvie *et al.*, 2004).

- vi. Encouraging “Green Modes”: any traffic congestion reduction strategy in Lagos should encourage development of “green modes” such as bicycles, cycle rickshaws and pedestrians (Sanjay, 2005). First of all, the safety concerns of cyclists and pedestrians have to be addressed adequately. For this purpose, there has to be a segregated right-of-way for bicycles and pedestrians. Apart from reducing congestion, it will also help improve safety, increase the average speed of traffic and reduce emissions resulting from slow speeds. To enable longer trip lengths on bicycles, bicycle technology should be improved.
- vii. Drivers’ enlightenment: there should be proper and adequate enlightenment for the drivers on the dangers inherent in congestion, and also dissuading them from certain congestion-causing habit such as wrong overtaking, one way driving, disobey of traffic signals and traffic wardens.

2.2.4 Analysis of Congested Flow

Traffic congestion can be measured in various ways, including roadway Level of Service (LOS), average traffic speed, and average congestion delay compared with free-flowing traffic (Litman, 2005). Some researchers however claimed that there is no standard way of measuring road congestion. They described traffic congestion as a subjective quantity as perceived by road users. In the same road condition, some may feel that the road is heavily congested, while some others may feel that the road is only slightly congested (Pongpaibool *et al.*, 2007).

Kerner (2004) distinguished several congestion patterns with respect to traffic flows as: Synchronised (SP) which is further subdivided into Moving Synchronised (MSP), Widening Synchronised (WSP), Localised Synchronised (LSP). A General Pattern (GP) contains both synchronised flow and wide –moving jams. The different types of GP are Dissolving GP (DGP), a GP under weak congestion, and a GP under strong congestion. An Expanded Pattern (EP) occurs when two bottlenecks are spatially close to each other. In order to accurately estimate, automatically track, and reliably predict the above identified congested traffic patterns, Kerner *et al.* (2001)

have developed two models: Forecasting of Traffic Objects (FOTO) and Automatische StauDynamik Analyse (ASDA)

Posawang *et al.* (2009) used artificial neural network (ANN) model that classify velocity and traffic flow into three congestion levels: light, heavy, and jam in service in the Bangkok Metropolitan Area. Duan *et al.* (2009) used floating car data to analyse the spatio-temporal characteristics of Shanghai traffic congestion. Aworemi *et al.* (2009) employed research questions to design ameliorative measures of road traffic congestion in Lagos metropolis.

2.3 Traffic Flow Modelling

Generally, models are tools designed to represent a simplified version of reality (Wang and Anderson, 1982; Ackoff and Sasieni, 1986). Neelamkavil (1987) defined a model as a simplified representation of a system intended to enhance our ability to understand, explain, change, preserve, predict, and possibly control, the behaviour of a system. Eisner (1988) described models as quantitative representative of a system. A model is also regarded as an object or concept which is used to represent something else that is reality converted to a comprehensive form (Meyer, 1985).

2.3.1 Types of Models

According to Ackoff and Sasieni (1986), three types of models are commonly used in science and engineering: iconic, analogue, and symbolic.

- i. Iconic models are images of the physical system they represent. They are either scale down (photographs, drawings, maps) or scaled up as in molecular structures. Iconic models are generally specific, concrete, and difficult for experimental purposes.
- ii. Analogue models are dynamic in character. Analogues use one set of properties to represent another set of properties. For example, contour lines on a map are analogues of elevation, and graphs are analogues that use geometrical magnitude and location to represent a wide variety of variables and the relationships between them. Analogue models are less concrete, but easier to manipulate than iconic models.
- iii. Symbolic (Mathematical) models use letters, numbers, and other types of symbols to represent variables and the relationships between them. They are the

most general and abstract type of models and the easiest to manipulate experimentally. Symbolic models take the form of mathematical relationships that reflect the structure of thta which they represent. When the relationships are given for steady state only, the model has static character and is described with algebraic equations only. However, dynamic mathematical models include transient as well as the steady state behaviour of a system, and are described by set of differential equations and by a set of boundary conditions.

2.3.2 Criteria for Model Selection

For models to be very useful, Wilson (1968) suggested that they should be:

- Small
- Modular
- Well documented
- Use very common languages
- Deal with specific rather than generalised problems. Generalised models are rarely suitable or efficient for specific use.
- Avoid complex techniques, except in the case of most technical problems having little social or political content.
- Provide for substantial user ability to see intermediate results, to modify the data prior to the next step, and generally intervene in the overall process of model use.

Agbede (1996) also suggested the following criteria in the choice of the most appropriate model for any given system.

- i. It should be sufficiently simple so as to be amenable to mathematical treatment.
- ii. It should not be too simple so as to exclude those features which are of interest to the system under study.
- iii. There must be information available for model calibration.
- iv. The model should be the most economic one for solving the problem.

A flow chart showing model usage for any typical engineering system is shown in figure 2.1. An overview of traffic flow models by Hoogendoorn and Bovy (2001) is presented in Table 2.1.

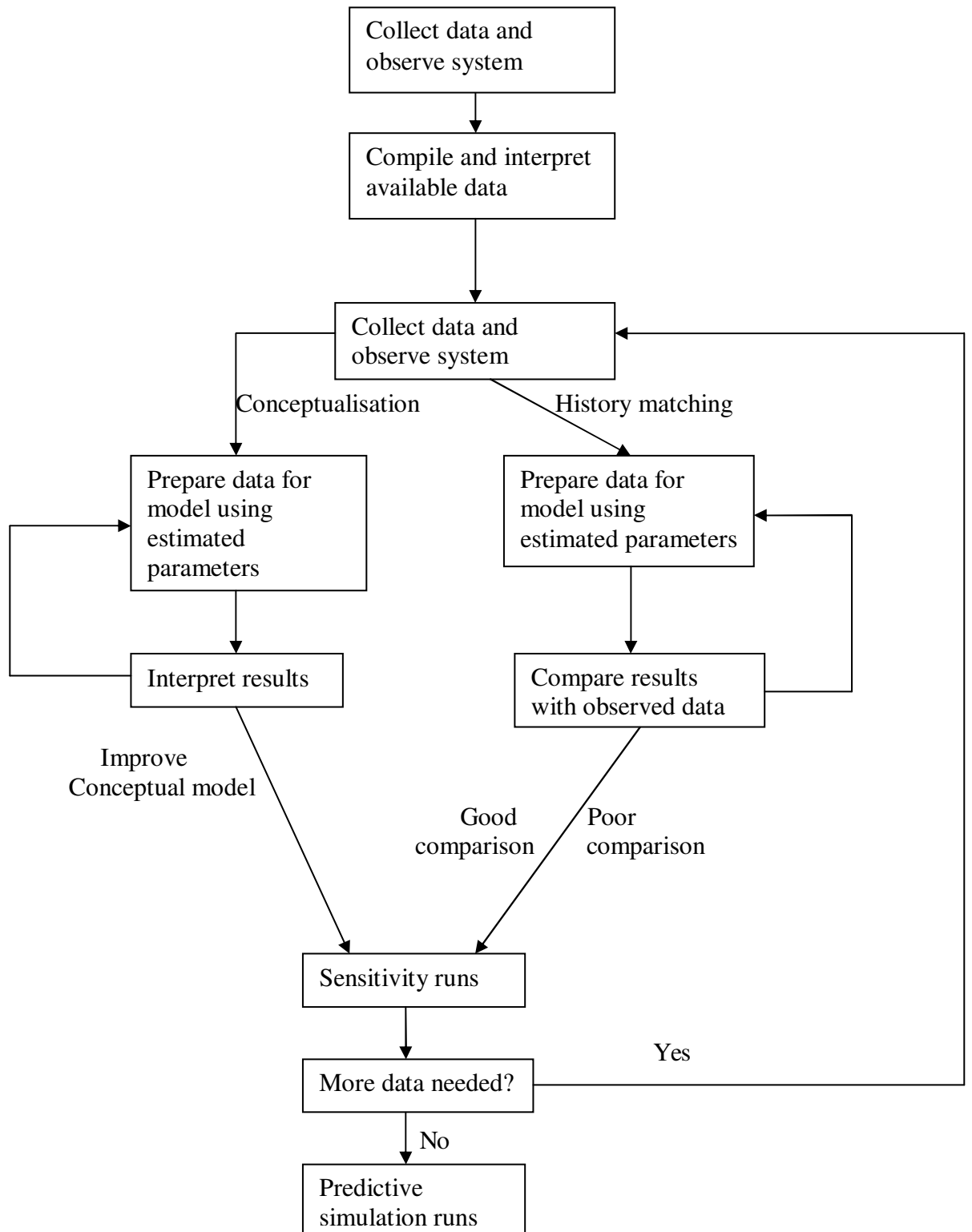

Fig 2.1: Model usage flow chart
Source: Agbede (1996)

Table 2.1: Overview of traffic flow models

detail level	MODEL NAME / REF.	DI				SC	RE	OP	AR
		v	v ⁰	y	o				
(sub-) microscopic models	MIXIC (Van Arem and Hogema (1995))	+		+	+	d	s	s	ml
	SIMONE (Minderhoud (1999))	+	+	+	+	d	s	s	ml, d
	PELOPS (Ludmann (1998))	+		+	+	d	s	s	ml
	safe-distance models (May (1990))	+				c	d	a	sl
	stimulus-response models (Leutzbach (1988), May (1990))	+				c	d	a	sl
	psycho-spacing models (Wiedemann (1974))	+	+	+		c	s	s	ml
	FOSIM (Vermijs <i>et al.</i> (1995))	+	+	+	+	d	s	s	ml, d
	CA-models (Nagel (1996,1998), Wu and Brilon (1999), Esser <i>et al.</i> (1999))	+	+			d	s	s	n, u
	Particle pedestrian model (Hoogendoorn and Bovy (2000a))	+	+	+	+	d	s	s	o
	INTEGRATION (Van Aerde (1994)).	+				d	d	s	n
mesoscopic models	headway distr. models (Hoogendoorn and Bovy (1998a))			+	+	c	s	a	c
	reduced gas-kinetic model (Prigogine and Herman (1971))	+				c	d	a	al
	improved gas-kinetic model (Paveri-Fontana (1975))	+	+			c	d	a	al
	multilane gas-kinetic model (Helbing (1997b))	+	+		+	c	d	a	ml, d
	multiclass gas-kinetic model (Hoogendoorn and Bovy (2000b))	+	+	+	c	d	a	al	
	multiclass multilane model (Hoogendoorn (1999))	+	+	+	c	d	a	al	ml, d
macroscopic models	cluster models (Botma (1978))	+	+			c	d	a	al
	LWR model (Lighthill and Whitham (1955))	+				c	d	a	al
	Payne-type models ((Payne (1971,1979))	+				c	d	a	al
	Helbing-type models (Helbing (1996,1997))	+			+	c	d	a	al
	Cell-Transmission Model (Daganzo (1994a,b,1999))	+				d	d	s	n
	METANET (Kotsialos <i>et al.</i> (1998,1999))	+				d	d	s	n
	semi-discrete model (Smulders (1990))					sd	s	a	al, d
	FREFLO (Payne (1979))	+				d	d	s	n
MASTER (Treiber <i>et al.</i> (1999))	+				d	d	a	ml	

DI: dimension (other than time / space): velocity v , desired velocity v^0 , lateral position y (lanes), and other
 SC: scale (continuous, discrete, and semi-discrete);
 RE: process representation (deterministic, stochastic);
 OP: operationalisation (analytical, simulation);

AR: area of application (cross-section, single lane stretches, multilane stretches, aggregate lane stretches, discontinuities, motorway network, urban network, and other).

Source: (Hoogendoorn and Bovy, 2001)

2.3.3 Traffic Simulation

Simulation is a particular type of modelling approach. It is quantitative and usable in place of the real system in order to represent the behaviour of that system (Eisner, 1988). Simulation is more of an art; it does not have specific theory that can be applied to solve problems. It is mastered more by practice, by actually modelling and simulating small systems (Hira, 2001).

Simulation modelling is usually associated with complex processes which cannot be readily described in analytical terms. It is increasingly being used in traffic flow studies to satisfy a wide range of requirements such as:

- Highway capacity estimation (Dey *et al.*, 2008)
- Intelligent transportation and intelligent vehicle simulations (Yin *et al.* 2009)
- Evaluation of alternative treatments in traffic management
- Design and testing of new transportation facilities (e.g., geometric designs)
- Operational flow models serving as a sub-module in other tools (e.g. model-based traffic control and optimisation, and dynamic traffic assignment)
- Training of traffic managers
- Safety Analysis (Lieberman & Rathi, 1997; Hoogendoorn & Bovy, 1998).

2.3.4 Traffic Simulation Models

Traffic simulation models are designed to emulate the behaviour of traffic in a transportation system over time and space to predict system performance. Simulation model runs can be viewed as experiments performed in the laboratory rather than in the field. The models include algorithms and logic to:

- generate vehicles into the system to be simulated.
- move vehicles into the system.
- model vehicle interactions.

Simulation models are becoming increasingly popular and effective tools for managing traffic flows (Gibson and Ross, 1977). Traffic flows are dynamic in nature and involve complex processes, which are difficult to characterise numerically (Radilat and Tiller, 1981). Traffic simulation models have unique characteristics because of the interactions among the drivers, vehicles, and roadway. Simulation modelling has evolved as a tool with the advent of the computer. Simulation models are mathematical/logical representations (or abstractions) of real-world systems, which take the form of software executed on a digital computer in an

experimental fashion (Lieberman and Rathi, 1997). Traffic flow simulations can be used to optimise traffic flows and capacity. Modelling gives the engineer the ability to inexpensively choose the best of alternatives before actually committing financial resources to the implementation of the improvement on the field (Kubel *et.al.*, 1978; Li *et al.* 2008).

During its more than forty years long history computer simulation in traffic analysis has developed from a research tool of limited group of experts to a widely used technology in the research, planning, demonstration and development of traffic systems (Pursula, 1999). In general, simulation is defined as dynamic representation of some part of the real world achieved by building a computer model and moving it through time (Drew 1968). The use of computer simulation started when D.L. Gerlough published his dissertation: "Simulation of freeway traffic on a general-purpose discrete variable computer" at the University of California, Los Angeles, in 1955 (Kallberg 1971). From those times, computer simulation has become a widely used tool in transportation engineering with a variety of applications from scientific research to planning, training and demonstration.

Several researchers have applied traffic flow theory to develop models to simulate traffic flows in many areas. Bandyopadhyay (2001) developed a computer simulation model for traffic flow on a city road in Calcutta having mixed traffic conditions by considering five types of vehicles: tram, double-decker bus, single-decker bus, minibus and car. A realistic and operational macroscopic traffic flow simulation model which requires relatively less data collection efforts was developed, calibrated and applied to simulate a section of the 1-64-40 corridor in the St. Louis metropolitan area by Haefner and Li (1998). Putcha *et al.* (2006) developed a new traffic flow model to predict the speed of the traffic in terms of the mean free flow speed and the density. Adebisi and Chiejina (1983) evaluated and calibrated some appropriate mathematical traffic flow models to demonstrate that a workable theoretical and empirical basis exists for characterising bus travel times which provided local bus transit planners in Kaduna an analytical framework.

2.3.5 Classifications of traffic simulation models

The availability of adequate mathematical models is a prerequisite to describe and solve traffic flow problems. Generally speaking, mathematical modelling of traffic flow results in a nonlinear dynamic system. The nonlinear and complicated characteristics of flow dynamics makes it difficult to have a universal traffic flow model that applies to all traffic situations at all times.

Generally, simulation models are classified into two as highlighted in the Federal Highway Administration (FHWA) Report on microsimulation process.

1. Classification based on the detail of the system

a. Microscopic Models: These models simulate the characteristics and interactions of individual vehicles. They essentially produce trajectories of vehicles as they move through the network. The processing logic includes algorithms and rules describing how vehicles move and interact, including acceleration, deceleration, lane changing, and passing manoeuvres.

Microscopic models are potentially more accurate than macroscopic simulation models. However, they employ many more parameters that require calibration.

b. Mesoscopic Models: These models simulate individual vehicles, but describe their activities and interactions based on aggregate (macroscopic) relationships. Typical applications of mesoscopic models are evaluations of traveller information systems. For example, they can simulate the routing of individual vehicles equipped with in-vehicle, real-time travel information systems. The travel times are determined from the simulated average speeds on the network links. The average speeds are, in turn, calculated from a speed-flow relationship. Most of the parameters of the microscopic models cannot be observed directly in the field (e.g., minimum distances between vehicles in car-following situations).

Chen *et al.* (2010) combined the mesoscopic headway distribution model and the microscopic vehicle interaction model to simulate different driving scenarios, including traffic on highways and at intersections. A mesoscopic approach with groups of vehicles is used in CONTRAM (Leonard *et al.* 1978), a tool for analysis of street networks with signalised and non-signalised intersections.

c. Macroscopic Models: These models simulate traffic flow, taking into consideration aggregate traffic stream characteristics (speed, flow, and density) and their relationships. Typically, macroscopic models employ equations on the conservation of flow and on how traffic disturbances (shockwaves) propagate in the system. They can be used to predict the spatial and temporal extent of congestion caused by traffic demand or incidents in a network; however, they cannot model the interactions of vehicles on alternative design configurations (Chakroborty, 2006).

Macroscopic traffic flow simulation models are easier and less costly to maintain. They are appropriate if the model development time and resources are limited,

although, they carry a risk that their representation of the real-world may be less accurate, less valid or inadequate (Lieberman and Rathi, 1997). Also, the parameters of the macroscopic models (e.g., capacity) are observable in the field.

Most of the well known macroscopic applications in traffic flow analysis area originate from the late 1960's or the early 1970's. The British TRANSYT-program (Byrne *et al.* 1982) is an example of macroscopic simulation of urban arterial signal control coordination and the American FREQ- and FREFLO-programs (Byrne *et al.* 1982) plus the corresponding German analysis tool (Cremer, 1979) are related to roadway applications.

2. Classification based on randomness in traffic flow

a. Deterministic Models: These models have no random variables; all entity interactions are defined by exact relationships (mathematical, statistical or logical). For example, it is assumed that all drivers have a critical gap of 5 s in which to merge into a traffic stream, or all passenger cars have a vehicle length of 4.9 m.

b. Stochastic Models: These models have processes which include probability functions. Stochastic simulation models have routines that generate random numbers. The sequence of random numbers generated depends on the particular method and the initial value of the random number (random number seed). Changing the random number seed produces a different sequence of random numbers, which, in turn, produces different values of driver-vehicle characteristics.

Stochastic models require additional parameters to be specified (e.g., the form and parameters of the statistical distributions that represent the particular vehicle characteristic). More importantly, the analysis of the simulation output should consider that the results from each model run vary with the input random number seed for otherwise identical input data. Deterministic models, in contrast, will always produce the same results with identical input data.

2.3.6 Traffic simulation model building

Lieberman & Rathi (1997) highlighted the basic steps in traffic simulation model development process as the following:

- Define the problem and model objectives
- Define the system
- Develop the model

- Calibrate the model - calibration is the process of quantifying model parameters using real-world data. It is often a difficult and costly undertaking.
- Model verification - verification is a structured regimen to provide assurance that the model performs as intended.
- Model validation - validation establishes that the model behaviour accurately and reliably represents real world system being simulated, over a range of conditions anticipated. Model validation involves the following activities.
 - Acquiring real world data which, to the extent possible, extends over the model’s domain.
 - Reducing and structuring these empirical data so that they are in the same format as the data generated by the model.
 - Establishing validation criteria, stating the underlying hypotheses and selecting the statistical tests to be applied.
 - Developing the experimental design of the validation study, including a variety of scenarios to be examined.
 - Performing the validation study.
 - Identifying the causes for any failure to satisfy the validation tests and repairing the model accordingly.

The validation activity is iterative. As differences between the model results and real world data emerge, the developer must “repair” the model, then revalidate. Considerable skill and persistence are needed to successfully validate a traffic simulation model.
- Documentation - traffic simulation models, as is the case for virtually all transportation models, are data intensive. To make good use of these models, users must invest effort in data acquisition.

2.3.7 Vehicle generation algorithm

Jia (2008) generated uniform random variables to simulate poisson arrival of cars on a freeway during a period of heavy flow. The probability density function of X is

$$f(x) = 0.15e^{-0.15(x-0.5)} \quad \text{for } x \geq 0.5 \quad (2.2)$$

Let X = the time headway for two randomly chosen consecutive cars.

(0.5 s is regarded as the minimum average time headway between the two cars).

After generating uniform random variables $U_i \in (0,1)$

$$U_i = 0.15e^{-1.5(x-0.5)} \quad (2.3)$$

$$X_i = \left(\ln \frac{U_i}{0.15} \right) / (-0.15) + 0.5 \quad (2.4)$$

Depending on a random number between (0.1) with uniform distribution, the vehicles generated were assigned into different routes.

Vehicle generation algorithm can also be developed by considering the mean headway (H) of vehicles (as given in equation 2.4) to generate vehicles at the beginning of the simulation run.

$$H = 3600/V \quad (2.5)$$

If the model uses the shifted negative exponential distribution to simulate the arrival of vehicles at the network entry node instead of the uniform distribution, then vehicles will be generated as time intervals:

$$h = (H - h_1) [\ln(1 - R_n)] + H - h_1 \quad (2.6)$$

where:

h = headway (in seconds) separating each generated vehicle

h_1 = specified minimum headway (e.g., 1.0 s)

R_n = random number (0 to 1.0)

2.4 Headway Distribution Models

Headway is the time interval between two consecutive vehicles passing an observation point (Luttinen, 2004). It has been described as the fundamental building blocks of traffic flow, because the inverse of the mean headway is the rate of flow (Dawson and Chimini, 1968; Salter and Hounsell, 1996). The traffic flow reaches its maximum value at the minimum value of headway.

At any period of time, the individual values of headway vary greatly. The extent of these variations depends largely on the highway and the traffic conditions. At low flow regimes, headway values vary from zero between overtaking

Hagring (1996) listed three requirements that headway distributions need to fulfil: they must fit the observed data well, describe driver behaviour adequately, and be useful for prediction. Most headway distribution models are probability distribution models (Abdul-Magd, 2007; Chakraborty, 2006; Salter, 1990). These

models are generally categorised into two classes: free traffic models and constrained traffic flow models (Helbing, 2001; and Nagatani, 2002). Free traffic models assume random arrival of vehicles, examples are negative exponential distribution, displaced negative exponential distribution (or shift negative exponential distribution), log-normal distribution, Pearson Type III distribution and Erlang distribution. The second is probability distribution models developed for both free traffic flow and constrained traffic flow. Although these models are more practical in urban transportation system, the parameters of the models are complicated (Zhang *et al.*, 2007). Examples are bunched exponential distribution and double displaced negative exponential distribution (Cowan, 1975).

2.4.1 Headway Distribution Models for Free Flow

Negative exponential distribution model (M1): This is the basic model for free flow distribution models. It assumes poisson arrivals of vehicles and it is valid when traffic flows are light. Detail descriptions of negative exponential distribution are given by many researchers: Kinzer (1933), Tolle (1971), Cowan (1975), Leuzbach (1988), Arasan and Koshy (2002).

$$\text{M1: } f(x) = 0 \quad (x < 0) \quad (2.7)$$

$$f(x) = 1 - e^{-\lambda x} \quad (x \geq 0) \quad (2.8)$$

λ is the flow rate (vehicles per time unit).

$$\text{M2: } f(x) = 0 \quad (x < \tau) \quad (2.9)$$

$$f(x) = 1 - e^{-\lambda(x-\tau)} \quad (x \geq \tau) \quad (2.10)$$

M3 (Erlang Distribution):

$$f(x) = 0 \quad (x < 0) \quad (2.11)$$

$$f(x) = \int_0^x \frac{(k\lambda)^k}{(k-1)!} x^{k-1} e^{-k\lambda x} dx \quad (x \geq 0) \quad (2.12)$$

M4 (Pearson Type III Distribution - Gamma Distribution):

$$f(x) = 0 \quad (x < 0) \quad (2.13)$$

$$f(x) = \int_0^x \frac{\lambda^k}{\Gamma(k)} x^{k-1} e^{-\lambda x} dx \quad (x \geq 0) \quad (2.14)$$

M5 (Log-normal Distribution):

$$f(x) = 0 \quad (x < 0) \quad (2.15)$$

$$f(x) = \int_0^x \frac{1}{\sqrt{2\pi\sigma}} \exp\left[-\frac{(\ln x - \mu)^2}{2\sigma^2}\right] dx \quad (x \geq 0) \quad (2.16)$$

where

$$\mu = \frac{\sum_{i=1}^n \ln x_i}{n}; \sigma^2 = \frac{\sum_{i=1}^n (\ln x_i - \mu)^2}{n-1} \quad (2.17)$$

2.4.2 Headway Distribution Models for Constrained Flow

M6 (Bunched Negative Exponential Distribution): It was first proposed by Cowan (1975). This model overcomes the shortcomings of negative exponential distribution and the displaced negative exponential distribution in predicting headway probabilities for small headways and for high arrival flow rates. The model assumes that a proportion of vehicles, θ , are tracking behind preceding vehicles at headway of τ . These vehicles are bunched. The rest are travelling at headways greater than τ and are described as free vehicles. The formula is as follows:

$$f(x) = 0 \quad (x < \tau) \quad (2.18)$$

$$f(x) = 1 - (1 - \theta)e^{-\gamma(x-\tau)} \quad (x \geq \tau) \quad (2.19)$$

Akcelik and Chung (1994) gave a detail description of the model in detail and gave the results of its calibration using real-life data for single-lane traffic streams and simulation data for multilane traffic streams. The traffic streams of the study sites are all unqueued.

M7 (General Bunched Exponential Distribution): This model is also developed by Cowan (1975). It is a further generalisation of the bunched exponential model and gives the tracking headway a general distribution as well. This model is certainly more realistic but more complex.

$$f(x) = 0 \quad (x < 0) \quad (2.20)$$

$$f(x) = \theta B(x) + (1 - \theta) \int_0^x B(x-u) \gamma e^{-\gamma u} du \quad (x \geq 0) \quad (2.21)$$

M8 (Double Displaced Negative Exponential Distribution (DDNED)): This model is developed by Griffiths and Hunt (1991).

$$f(x) = 0 \quad (x < \tau) \quad (2.22)$$

$$f(x) = \phi \lambda_1 e^{\lambda_1(x-\tau)} + (1 - \phi) \lambda_2 e^{\lambda_2(x-\tau)} \quad (x \geq \tau) \quad (2.23)$$

Where $0.5 \geq \phi > 0$.

The parameter Φ is weighting factor, τ is the displacement parameter, and λ_1, λ_2 are constants associated with the traffic flow. Sullivian (1994) observed that DDNED can model smaller headways more accurately than the Bunched Negative Exponential model.

M9 (Composite Distribution):

$$f(x) = 0 \quad (x < 0) \quad (2.24)$$

$$f(x) = (1 - \theta)F_1(x) + \theta F_2(x) \quad (x \geq 0) \quad (2.25)$$

where

θ is the proportion of the followers

$F_1(x)$ is the distribution for leaders, usually a negative exponential distribution

$F_2(x)$ is the distribution for followers.

Although the models above can fit the real traffic situation well, the derivation of unknown parameters is complicated.

In Table 2.2, a comparison of headway distribution models is presented.

2.4.3 Parameter estimation and calibration of headway models

The process of headway model development consisted of testing the field data by using a number of existing simple models and progressing with increasing degrees of complexity until an acceptable match between the field data and the model output is obtained (Khasnabis & Heimbach, 1980). Several researchers have employed simple mathematical models based on Poisson and Erlang distributions to estimate headway parameters for flows at low levels. Complex mathematical headway distribution models such as Log-normal, Pearson Type III and Hyperlang are however employed in parameter estimation of high flows.

Parameters of headway distribution models must be properly estimated before the models can be applied. Their goodness of fit is significantly affected by the quality of the estimated parameters (Zhang *et al.*, 2007). Hagrind (2000) highlighted three methods usually employed in headway parameters estimation: the method of moments, the maximum-likelihood method and the least-squares method. Zwahlen *et.al*, (2007) employed the least-squares method to generate hyperbolic fit distributions to approximate headway distributions of free-flowing traffic on Ohio Freeways.

Table 2.2: Comparison of headway distribution models

Distribution Model	Equations	Research Objective or Character of Study Site	Addition
M1: Negative Exponential Distribution	$f(x) = 0$ $f(x) = 1 - e^{-\lambda x}$	Random arrival under light traffic volume.	-
M2: Displaced Negative Exponential Distribution	$f(x) = 0 (x < \tau)$ $f(x) = 1 - e^{-\gamma(x-\tau)} \quad (x \geq \tau)$	Random arrival under light traffic volume.	-
M3: Erlang Distribution	$f(x) = 0 \quad (x < 0)$ $f(x) = \int_0^x \frac{(k\lambda)^k}{(k-1)!} x^{k-1} e^{-k\lambda x} dx$ $(x \geq 0)$	Random arrival under light traffic volume.	-
M4: Pearson Type III	$f(x) = 0 \quad (x < 0)$ $f(x) = \int_0^x \frac{\lambda^k}{\Gamma(k)} x^{k-1} e^{-\lambda x} dx$ $(x \geq 0)$	Random arrival under light traffic volume. Data collected from highway of U.S.A. were tested. Volumes from 551 to 1369 vph. Not fit well.	-
M5: Log-normal Distribution	$f(x) = 0 \quad (x < 0)$ $f(x) = \int_0^x \frac{1}{\sqrt{2\pi\sigma}} \exp\left[-\frac{(\ln x - \mu)^2}{2\sigma^2}\right] dx$ $(x \geq 0)$ where $\mu = \frac{\sum_1^n \ln x_i}{n}; \sigma^2 = \frac{\sum_1^n (\ln x_i - \mu)^2}{n-1}$	Random arrival under light traffic volume. Data collected from highway of U.S.A. were tested. Volumes from 551 to 1369 vph. Fit better than M4.	-
M6: Bunched Negative Exponential Distribution	$f(x) = 0 \quad (x < \tau)$ $f(x) = 1 - (1 - \theta)e^{-\gamma(x-\tau)} \quad (x \geq \tau)$	Tested in single lane and multi-lane road in Australia. Widely used for estimating capacity and performance of roundabouts and other unsignalised junctions.	Different sites with different location of lane.

<p>M7: General Bunched Exponential Distribution</p>	$f(x) = 0 \quad (x < 0)$ $f(x) = \theta B(x) + (1 - \theta) \int_0^x B(x-u) \gamma e^{-\gamma u} du \quad (x \geq 0)$	<p>Constrained Traffic Flow</p>	<p>No application presented in the literature.</p>
<p>M8: Double Displaced Negative Exponential Distribution</p>	$f(x) = 0 \quad (x < \tau)$ $f(x) = \phi \lambda_1 e^{-\lambda_1(x-\tau)} + (1-\phi) \lambda_2 e^{-\lambda_2(x-\tau)} \quad (x \geq \tau)$ <p>where $0.5 \geq \phi > 0$.</p>	<p>Study site: traffic stream in single lane in busy urban area in U.K. Fit well with the small headway as well as large headway.</p>	<p>Using a hybrid method of maximum likelihood method and method of moments to derive unknown parameters</p>
<p>M9: Composite Distribution</p>	$f(x) = 0 \quad (x < 0)$ $f(x) = (1-\theta)F_1(x) + \theta F_2(x) \quad (x \geq 0)$	<p>A test was carried out at single lane and two-lane signalized junctions, traffic flow level from 500 to 2000 vph on Tokyo Expressway.</p>	<p>Result of through + left turn lane was given.</p>

2.5 Highway Capacity

Highway capacity can be described as the ability of a roadway to respond to drivers and vehicles. The ability of roadway is revealed as a vehicle's speed and time headway (Hwang *et al*, 2005). In HCM2000 (Transportation Research Board, 2000) capacity is described as maximum sustainable flow rate at which vehicles or persons reasonably can be expected to traverse a point or uniform segment of a lane or roadway during a specified time period under given roadway, geometric, traffic, environmental, and control conditions; usually expressed as vehicles per hour, passenger per hour, or persons per hour. The HCM method consists of three major steps. The first step is to find the capacity of highway facilities under ideal conditions. Second, the levels of service are selected to represent different operating qualities and to determine the maximum flow rates under these different levels of service. Finally, adjustment factors due to prevailing roadway and traffic conditions are applied to the ideal conditions to obtain the maximum flow rates at different levels of service. Capacity of a road is the major aspect for dimensioning the carriageway.

The capacity corresponds to the maximum traffic volume that can be achieved by a traffic stream at a specific junction under given road and traffic conditions. For highways operating under ideal conditions, the general expression for capacity is given in equation 2.26

$$C = q_{\max} \quad (2.26)$$

where q_{\max} is the maximum traffic volume. However, for any segment of highways operating under non-ideal conditions, its practical capacity will normally be smaller than the basic capacity as given by equation 2.27

$$C_p = C \times \prod_j f_j \quad (2.27)$$

where C_p = practical capacity

C = basic capacity

f_j = adjustment factor for the condition j

2.5.1 Factors affecting capacity

Highway capacity is affected by many factors as given by Wright (1996). The factors include: desired speed, number of lanes, separation of directions, vertical grade, composition of traffic, peak traffic factor and capacity of intersections.

Many of the procedures described in the HCM are based on simple tables or graphs for specified standard conditions, which must be adjusted to account for prevailing conditions different from those specified. The conditions so defined are often described in terms of ideal conditions.

Ideal conditions for uninterrupted flow facilities include:

- 3.65 m lane widths
- 1.8 m clearance between the edge of travel lanes and the one roadside obstructions
- all passenger cars in the traffic stream
- a driver population comprised predominantly of regular and familiar i of the facility

An ideal signalized intersection approach has

- 3.65 m lane widths
- level grade
- no curb parking allowed on the intersection approaches
- all passenger cars in the traffic stream
- no turning movements at the intersection
- intersection located outside the central business district
- green signal available at all times

Since prevailing conditions are seldom ideal, computations of capacity must be adjusted to account for departure from ideal (Oglesby and Hicks, 1982; Wright and Dixon, 2004). Prevailing conditions may be grouped into three categories: roadway, traffic or control conditions.

Roadway factors include:

- the type of facility and its development environment
- lane widths
- shoulder widths and/or lateral clearances
- design speed
- horizontal and vertical alignments

Traffic conditions refer to the types of vehicles using the facility and how traffic flow is distributed by lane use and direction. It is well known that and heavier vehicles have an adverse effect on traffic flow in a number of ways. In addition to the distribution of vehicle types, the effects of two other

characteristics on capacity, service flow rates, and level of service must be considered.

2.5.2 Need for highway capacity analysis

Generally, highway capacity analysis serves three purposes (Khisty and Lall, 2006; Kadiyali, 2007):

- i. To assess the adequacy or sufficiency of existing highway networks and to estimate when traffic growth is likely to exceed capacity;
- ii. To assist in the selection of the highway type and the dimensional needs of the network
- iii. To prepare estimates of operational improvements that are likely to be expected in the future from prospective changes in traffic control or highway geometry.

In urban centres, capacity analysis is prerequisite to the development of appropriate highway development schemes (Osula, 2010). According to Coombe and Chua (1990), the subsequent improvements will have multiple effects on the highway system as follows:

- i. People may reschedule the timing of their trips to take advantage of the improved conditions at peak periods (peak contraction);
- ii. People may divert to use the improved part of the network (reassignment);
- iii. People switch from public transport to use their vehicles more (modal choice);
- iv. Improved road accessibility may encourage trips to be made to destinations further afield (redistribution);
- v. Improved levels of service on the road system may lead to increased rates of trip making for any given level of income, car ownership, population and employment (trip generation);
- vi. Improved road accessibility may lead to people buying more cars for any given income level; and
- vii. Improved roads may encourage land use to change, leading to population and employment changes in their vicinity.

2.5.3 Capacity analysis methods

Capacity analysis is a procedure used to estimate the traffic carrying ability of a facility over a range of defined operational conditions. It also aids in providing tools for the analysis and improvement of existing facilities, and for planning and design of future facilities (Oguara, 2006). A principal objective of capacity analysis is the estimation of the maximum number of people or vehicles that can be accommodated by a given facility in reasonable safety within a specified time period. Planning, design, dimensioning and operation of highway infrastructures depend on the functions of the highway facility. Capacity analysis of a highway facility should furnish an answer to the question whether a road facility will be operational for a given or forecasted travel demand. A capacity analysis result should produce a yes/no statement indicating whether the facility will work (demand lower than capacity) or fail (demand higher than capacity).

Two widely used highway capacity estimation methods are the Highway Capacity Manual (HCM) method and the statistical method.

2.5.3.1 The Highway Capacity Manual method

This method is based on speed-volume-density relationship. The HCM is the authoritative guide for the performance of highway capacity analyses. The manual reflects over 40 years of comprehensive research by a number of research agencies. This document was prepared under the guidance of the Transportation Research Board's Committee on Highway Capacity and Quality of Service.

The procedures described in the HCM cover a wide range of facilities, including streets and highways as well as facilities for transit, pedestrians, and bicyclists. Capacity analyses are performed for two general categories of facilities, those with uninterrupted flow and those with interrupted flow. Uninterrupted flow facilities include two-lane highways, freeways, and other multilane highways. The traffic flow conditions on such facilities result from interactions among vehicles in the traffic stream as well as between vehicles and the physical and ambient characteristics of the roadway (Wright, 1996).

Hwang *et.al* (2005) pointed that whenever HCM is published, highway capacity is increased; 1,800pc/h/l (HCM, before 1986), 2,000pc/h/l (HCM, 1986), 2,200pc/h/l (HCM, 1994), 2,400pc/h/l (HCM, 2000). They claimed that previous results are due to two main reasons: previous research has not given much consideration to road conditions, traffic conditions, control conditions, technology

factors, which affect highway capacity. Second, previous research has used rough 15-min base traffic data.

2.5.3.2. The British Standard Approach

This method is based upon empirical British research studies related to different discrete aspects of road operation and analysis. As a result of these studies, practical capacity design standards for use in rural and urban roads have evolved (May, 2001).

In Table 2.3 below, the recommended design flows for two-way urban roads is shown.

Table 2.3: Recommended design flows for two-way urban roads

Road Type	Peak flows (veh/h) for carriageways of width (m)											
	Single carriageways*								Dual carriageways			
	2-lane*		4-lane+		6-lane+		2-lane+	3-lane+				
	6.1	6.75	7.3	9	10	12.3	13.5	14.6	18	6.75	7.3	11
A Urban motorway, no frontage access, grade-separation at intersections										3600	5700	
B All-purpose road, no frontage access, no standing vehicles, negligible cross-traffic			2000	3000		2550	2800	3050		2950*	3200*	4800*
C All-purpose road frontage Development, side roads, pedestrian crossings, bus stops, waiting restrictions throughout the day, loading restrictions at peak hours	1100	1400	1700		2200	2500	1700	2100	2700			

*Total for both directions of flow; 60/40 directional split can be assumed; + for one direction of flow; • includes division by line of refuges as well as central reservation; effective carriageway width excluding refuge width is used.

Source: O’Flaherty (2001)

2.5.3.3 Statistical method

The statistical method makes use of observed traffic volume distribution. The summary of the method are:

- detecting peak hour 1 minute base volume and average speed
- transferring 1 minute base data to 15 minute base one
- finding time headway distribution using average volume
- determining highway capacity when confidence intervals are 99%, 95% and 90%.

With this method, Chang and Kim (2000) found that the estimated highway capacity is 2200pc/h/l at the 95% confidence interval.

2.5.3.4 Dynamic highway capacity estimation method

This method was developed by Hwang *et al.* (2005). In this method a roadway capacity is assumed to be a function of the driver and vehicle conditions, vehicle speed, and time headway, as defined by equation 2.28

$$C_i = f(d, v_c, s, h) \quad (2.28)$$

where C = capacity of roadway i. d = driver condition

v_c = vehicle condition s = vehicle speed

h = time headway (seconds)

Unit time of highway capacity estimation is one hour, equation 2.29 can be drawn

$$C = \left\{ \frac{3600}{h} \mid h = g(d, v_c, s) \right\} \quad (2.29)$$

2.5.3.5 Safety-based capacity analysis

developed by Yi *et al.* (2004) for Chinese highways. The development was prompted by the claim of the researchers that none of the existing capacity analysis can be readily used on Chinese highways. Numerical approach through simulation was used to find a simplified mathematical form of free flow speed based on distance headway.

2.5.4 Level of Service (LOS)

The Level of Service (LOS) is a qualitative concept that has been developed to characterise acceptable degrees of congestion as perceived by motorists (O'Flaherty, 2001). It is commonly accepted as a measure of the restrictive effects of increased volume (Oglesby and Hicks, 1982). In metropolitan areas, the capacity of the road networks affects the level of service, ranging from flow conditions to congested

conditions on roads, and high to low frequency of services on public transport (Oluwoye, 2009).

Six levels of service (Levels A through F) define the full range of operating conditions with LOS A representing the best or ideal to LOS F being the worst or forced flow condition as shown in Table 2.4. The appropriate degree of congestion to be used in planning and designing highway improvements is determined by considering a variety of factors. These factors include the desires of the motorists, adjacent land use type and development intensity, environmental factors, and aesthetic and historic values. The factors must be weighed against the financial resources available to satisfy the motorists' desires.

The service flow rate for a designated LOS is the maximum hourly rate at which vehicles reasonably can be expected to traverse a point or uniform section of a lane or roadway during a given time period under prevailing roadway, traffic, and control conditions.

Table 2.4: Level-of-Service Characteristics

Level of Service	Description
A	Free flow with low volumes and high speeds.
B	Reasonably free flow, but speeds beginning to be restricted
	traffic conditions.
C	In stable flow zone, but most drivers are restricted in the freedom to select their own speeds.
D	Approaching unstable flow; drivers have little freedom to
	select their own speeds.
E	Unstable flow; may be short stoppages
F	Unacceptable congestion; stop-and-go; forced flow.

Source: Adapted from the AASHTO Green Book. ¹ 1995 Highway Capacity Manual (Special Report 209), Transportation Research Board, Washington, DC, Third Edition, updated 1994

Table 2.5 presents the relationship between highway type and location and the level of service appropriate for design as suggested by the AASHTO Green Book. Taking into consideration specific traffic and environmental conditions, the responsible highway agency should attempt to provide a reasonable and cost-effective level of service.

It has been claimed that the LOS is more of an engineering tool useful for assessing and planning operational analyses. This is because it is difficult to calculate as the defined standards at which the different levels are set always depend on the specific type of traffic situation that is studied (Maerivoet and De Boor, 2005). However, Polus and Cohen (2009) have proposed a new level-of-service variable that can be easily estimated from the field data to measure the quality of the flow both inside and between platoons.

2.5.5 Acceptable Degrees of Congestion

AASHTO (2001) suggests some principles to aid in deciding on the acceptable degree of congestion.

- Traffic demand should not exceed the capacity of the highway even during short intervals of time.
- The design traffic volumes per lane should not exceed the rate at which traffic can dissipate from a standing queue.
- Motorists should be given some latitude in the choice of speeds (speeds could be related to the length of the trip).
- Operating conditions should provide a degree of freedom from driver tension that is consistent with trip length and duration.
- There are practical limitations to having an ideal roadway.
- The attitude of motorists toward adverse operating conditions is influenced by their awareness of the construction and right-of-way costs necessary to improve service.

Table 2.5: Guide for Selection of Design Levels of Service

Highway Type	Type of Area and Appropriate Level of Service			
	Rural Level	Rural Rolling	Rural Mountainous	Urban and Suburban
Freeway	B	B	C	C
Arterial	B	B	C	C
Collector	C	C	D	D
Local	D	D	D	D

Source: Adapted from the AASHTO Green Book. ¹ 1995 Highway Capacity Manual (Special Report 209), Transportation Research Board, Washington, DC, Third Edition, updated 1994

2.5.6 Design hourly volume

The design hourly volume is one-hour vehicular volume in both directions of travel in the design year selected for travel. The capacity analysis is based on the idea that for economic reasons a transport facility will never be designed to accommodate the highest possible traffic volume. In fact a certain congestion frequency is accepted. For this reason, the design hourly volume is defined as the traffic volume which occurs during the 30th largest peak hour within a year. The 30th peak hour is determined by sorting, in a descending order, the hourly traffic volumes of all 8760 hours of a year. From this list the value number 30 is Capacity selected as hourly traffic volume. It is accepted that during these 30 hours the level of service of the facility will be low. However for the rest of the time period the facility will accommodate the traffic at a required level.

2.5.7 Capacity of two-lane highways

A two-lane highway is an undivided highway having one lane for use by traffic in each direction, and over-taking of slower vehicles requires the use of the opposing lane when sight distance and gaps in the opposing traffic stream permit (Salter, 1990). The principal function of two-lane highways is efficient mobility (Khisty and Lall, 2006). With a low traffic volume, the vehicle operator has wide latitude in selecting the speed at which he wishes to travel. As traffic volume

increases, the speed of each vehicle is influenced in a large measure by the speed of the slower vehicles. As traffic density increases, a point is finally reached where all vehicles are travelling at the speed of the slower vehicles. This condition indicates that the ultimate capacity has been reached.

Capacity expansion is one way of reducing traffic congestion, although some studies indicate that this approach provide only slight reductions in urban traffic congestion (TTI, 2009). Capacity expansion is one of the approaches suggested by Aworemi *et al.* (2009) in addressing the consistent traffic congestion experienced by motorists on Lagos roads.

2.5.8 Capacity analysis of two-lane highways

Two-lane highways can be analysed either as two-way segments obtaining traffic performance measures for both direction of travel combined or as directional segments, with each direction of travel considered separately. The following presents the simplified procedure for conducting a capacity analysis for the highway mainline:

1. Select the design year.
2. Determine the DHV.
3. Select the target level of service.
4. Identify and document the proposed highway geometric design (e.g. lane width, clearance to obstructions, number and width of approach lanes at intersections).
5. Using the HCM, analyse the capacity of the highway element for the proposed design:
 - (a) Determine the maximum flow rate under ideal conditions (MSF);
 - (b) Identify the adjustments for prevailing roadway, traffic and control conditions; and
 - (d) Calculate the service flow rate (SF) for the selected level of service.

The service flow rate for two-lane highways (Wright, 1996; and Oguara, 2006) is given by equation 2.30. The maximum service volume under ideal conditions is given in Table 2.6.

$$SF_i = 2800 \times (v/c)_i \times f_d \times f_w \times f_{Hv} \quad (2.30)$$

where

$$(v/c)_i = \text{maximum volume-to- capacity ratio associated with level of service } i$$

- f_d = adjustment factor for directional distribution of traffic
- f_w = adjustment factor for lane width and/or lateral clearance restrictions
- f_{Hv} = adjustment factor for the presence of heavy vehicle in the traffic

stream

Table 2.6: Maximum service volumes under ideal conditions

Level of Service	Passenger cars per hour per lane in one direction				
	Design speed = 113 km/h		Design speed = 97 km/h		
	Freeway	Multi-lane	Freeway	Multi-lane	Two-lane*
A	700	700	-	650	420
B	1100	1100	1000	1000	756
C	1550	1400	1400	1300	1204
D	1850	1750	1700	1600	1792
E	2000	2000	2000	2000	2800
F	**	**	**	**	**

* For both directions: level terrain segment with ideal geometries

** Unstable, highly variable

Source: Adapted from Oguara (2006)

CHAPTER 3

METHODOLOGY

3.1 Traffic Survey

In line with the objectives of this study, Traffic survey was conducted on three purposively selected heavily-trafficked two-lane highways (Total Garden-Agodi Gate, J Allen-Oke Bola and Odo Ona-Apata) in the Ibadan metropolis. The selection was based on the regular traffic congestion usually experienced on some segments of these roads during morning peak period (7.00 am and 8.30 am) and evening peak period (4.00 pm and 6.00 pm). Traffic survey was conducted on the roads between February 2008 and April 2009 to capture the stream characteristics and road features. These include traffic composition, average speed of travel, location of bus-stops and notable features along the routes of study.

3.2 Traffic Data Collection

Video camera technology was employed to capture headway data for this study. Early studies used pneumatic tubes for traffic data collection. This method is easily capable of providing volume counts and therefore flow rates directly, and with care can also provide time headways (Garner and Uren, 1973; Hall, 1997). More recent systems have used paired presence detectors, such as inductive loops spaced about five to six meters to provide direct measurement of volume and of time headways, as well as of speed when pairs of them are used. Owolabi and Adebisi (1993) employed these methods to collect headway data along Zaria-Samaru Road using a pen recorder instrument connected to an automatic traffic counter and simultaneously monitored flows with the same device.

Video camera technology is a more recent method of traffic data collection (Hall, 1997). In its earliest application, video cameras were used to acquire data in the field, which was then subsequently played back in the laboratory for analysis. In these early implementations lines were literally drawn on the video monitor screen for data reduction. This procedure has been automated and the data reduction can now be conducted simultaneously with data acquisition.

The video camera used for this study is SONY HDR-HC3 camcorder. The detail operation of the camera is given in Appendix A1.

3.2.1 Headway data capturing and extraction

At various times within the period of traffic survey, some sections of the roads were focused in the field of a Sony HDR-HC3 Camcorder (Plate 3.1). Headway data were captured during morning peak period (7.00 am and 8.30 am) and evening peak period (4.00 pm and 6.00 pm) from Monday to Friday of each week.

The video data recorded in Digital 8 camera tapes was transferred to compact discs in mpeg format. The compact discs were played on a computer using Media Player software, which allowed for variable play speed settings at normal, slower or faster speed. The media player also had enhancement option to move the video forward or backward one frame at a time. This made it a little easy to record times successive vehicles pass the selected reference line on the screen for the exercise. The headway data was partitioned into 15-minute time intervals. The vehicle counts for each 15-minute time period were multiplied by 4 to obtain the hourly traffic volume (HCM 2000).

3.3 Headway Modelling Process

3.3.1 Theoretical Headway Generation Algorithm

The following steps were employed to generate theoretical headways of traffic streams based on the composition of observed headways.

1. Define headway group G_i .

$$(i) \quad h_i \in G_i \quad (3.1)$$

$$(ii) \quad d_i \leq h_i < e_i \quad (3.2)$$

i is the group number, d_i and e_i are lower and upper boundary limits respectively, h_i are headways in G_i for a specified traffic volume V .

A necessary boundary condition is

$$(iii) \quad d_{i+1} = e_i \quad (3.3)$$

for G_{i+1} , to avoid overlapping.

2. Group composition factor $k_1, k_2, k_3 \dots k_i$ was assigned to each group respectively

$$\text{where} \quad \sum_1^i k_i = 1 \quad (3.4)$$

3. Random variates h_n were generated such that

$$(i) \quad d_i \leq h < e_i \quad (3.5)$$

$$(ii) \quad \sum h = k_i T \quad (3.6)$$

$$(iii) \quad \sum_1^i k_i T = T$$

(3.7)

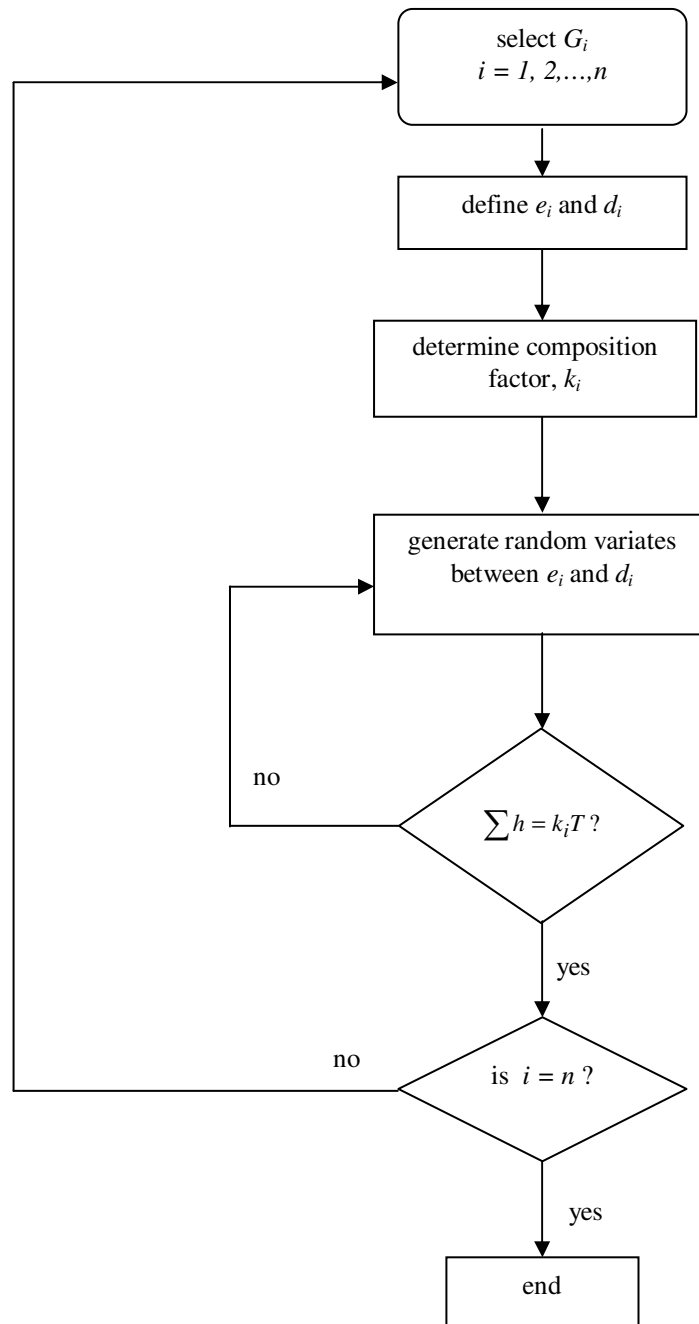

Fig. 3.1.Theoretical headway generation algorithm (THEGA) flowchart

3.3.2 Hyperbolic headway distribution models

The stepwise procedure employed here was based on the methodology described in the work of Zwahlen *et al.* (2007).

1. The database of the theoretical headways for each traffic flow regime starting from 700 in steps of 10 till 1200 based on the algorithm developed in Section 3.3.1 was prepared with electronic spreadsheets.
2. 18 cumulative percentiles of the theoretical headways were extracted at 1, 2, 3, 4, 5, 10, 20, 30, 40, 50, 60, 70, 80, 90, 95, 98, 99 and 100% at each flow regime. The purposively selected percentiles appeared to be adequate for capacity analysis of the highways studied. Cumulative percentages were used in determining the headways distributions since they are best suited for statistical tests such as Kolmogorov-Smirnov goodness-of-fit test.
3. Hyperbolic fit headway distribution model of the form was generated at each percentile.

$$H = a/V + b \quad (3.8)$$

Coefficients a and b were determined by the least-squares method. R^2 (coefficient of correlation) provided a measure of the quality of fit.

4. Preparation of extracted cumulative headway values from the hyperbolic models for specified range of traffic volumes (700 – 1200 vph).
5. Computation of adjustment factor, A . A was computed as the ratio of the average headways from the hourly traffic volumes and the weighted average for the hyperbolic fit models at each traffic flow.

$$A = \frac{3600}{V} \div \sum_{j=1}^m \left[(P_{j+1} - P_j) * \frac{1}{2} (H_{j+1} + H_j) \right] \quad (3.9)$$

where P_j is the cumulative percentage value from the hyperbolic fit table and H_j the corresponding headway, m is the number of cumulative percentiles extracted.

6. Fine-tuning the hyperbolic fit table prepared in No.4 above by multiplying headways at each percentile by the adjustment factor, A .
7. For a specified traffic volume V within the range of generated hourly traffic volumes, headway distribution, H , was obtained by linear interpolation.

$$H = H_1 + [(V - V_1)/(V_2 - V_1)] * (H_2 - H_1) \quad (3.10)$$

where

V_1 and V_2 were the traffic volumes at lower and upper values of traffic volume interval where V lies,

H_1 and H_2 were cumulative headway values at V_1 and V_2 respectively.

8. The steps highlighted in Nos. 1 to 6 above were used to prepare a cumulative headway distribution spreadsheet for the 2-lane highways studied.

3.4 Traffic Flow Simulator (TRAFLOS)

The results of the preliminary traffic study showed that the two-lane highways studied were not operating under ideal roadway, traffic and control conditions. A Traffic Flow Simulator (TRAFLOS) was subsequently developed for two-lane highways operating under such non-ideal conditions. Flows were simulated based on the preselected minimum and maximum headways between consecutive vehicles.

3.4.1 TRAFLOS Algorithm

The procedure for simulating flow on TRAFLOS is as follows:

1. Specify observation period, T to simulate traffic congestion scenario.
2. For a particular scenario, specify h_1 and h_2 as the minimum and maximum headways respectively. h_1 and h_2 were approximated percentile values obtained from the modelling process in Section 3.4
3. Generate random variates h_n such that

$$(i) \quad h_1 \leq h_n < h_2 \quad (3.11)$$

$$(ii) \quad V_R = \sum_{n=1}^{k_c} h_n \quad (3.12)$$

where;

V_R = number of vehicles (n) released per simulation run

k_c = congestion factor

T = the total headway in seconds.

The flow chart for the steps above is shown in Fig. 3.2. The algorithm developed above was coded in JAVA programming language. It has Graphical User Interface (GUI) that provides the user with text fields for the experiment parameters and a button to initiate the experiment. An “exit” button is also provided to close the application. The progress of the experiment is shown on a white pad in the interface

which shows headways as they are generated and the vehicle releases with the time each vehicle was released (Plate 3.2). Another white pad shows the summary of the experiment at the end of each run.

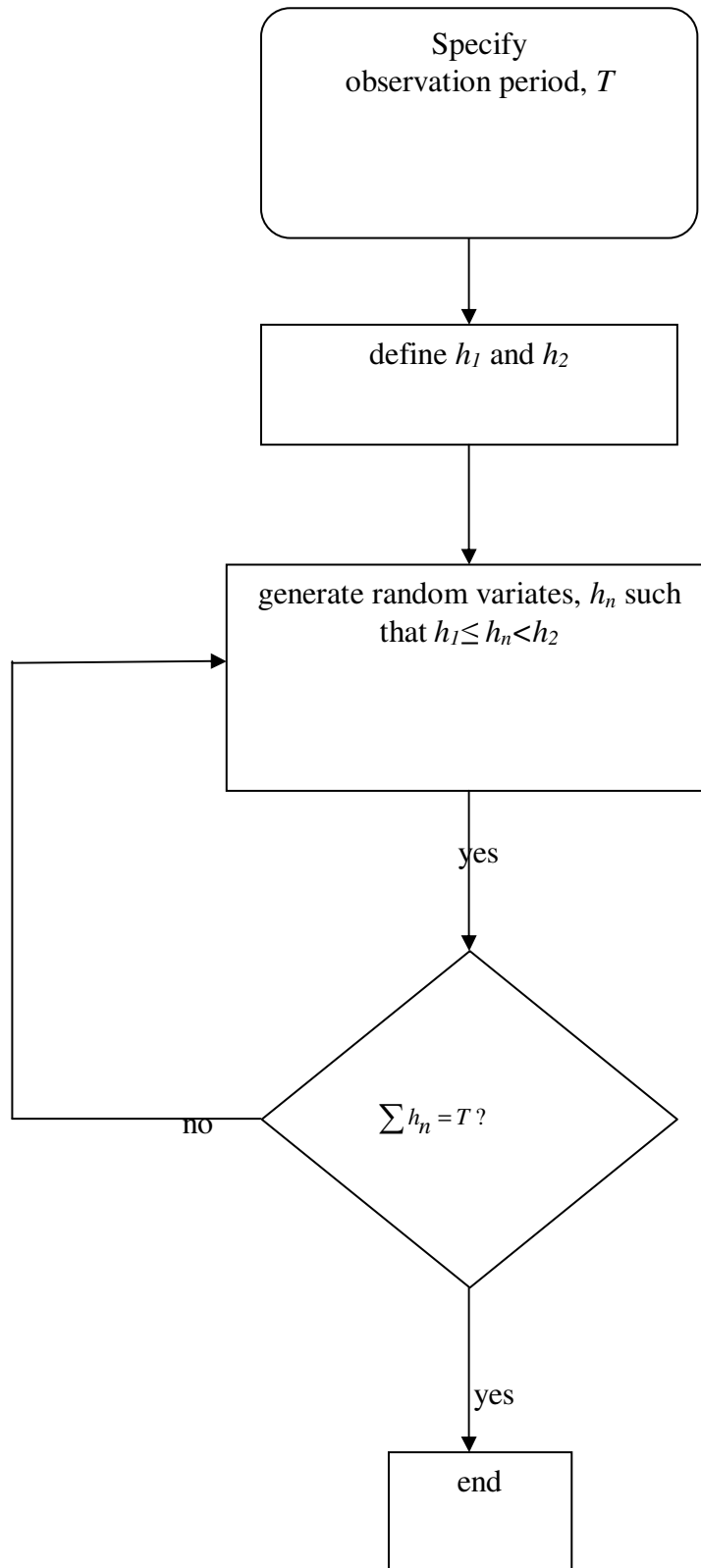

Fig. 3.2. Traffic flow simulator flowchart

3.5 Experimental Design of Congestion Scenarios

Based on the preliminary traffic study, the different congestion scenarios were simulated with TRAFLOS by varying the minimum and maximum headways between 1 and 18 seconds as shown in Table 3.1. The observation period was set at 15 minutes (900 seconds) for each scenario. A total of 171 experimental runs were carried out over a period of 2,565 minutes. The maximum service flow rate for each run was computed by equation 3.13 below:

$$V = 4 * V_R \quad (3.13)$$

where V_R = number of vehicles released at each experimental run.

Table 3.1: Congestion Scenarios Design Template

		Maximum Headway (seconds)																			
		1	2	3	4	5	6	7	8	9	10	11	12	13	14	15	16	17	18		
Minimum Headway (seconds)	1	*	*	*	*	*	*	*	*	*	*	*	*	*	*	*	*	*	*		
	2		*	*	*	*	*	*	*	*	*	*	*	*	*	*	*	*	*	*	
	3			*	*	*	*	*	*	*	*	*	*	*	*	*	*	*	*	*	*
	4				*	*	*	*	*	*	*	*	*	*	*	*	*	*	*	*	*
	5					*	*	*	*	*	*	*	*	*	*	*	*	*	*	*	*
	6						*	*	*	*	*	*	*	*	*	*	*	*	*	*	*
	7							*	*	*	*	*	*	*	*	*	*	*	*	*	*
	8								*	*	*	*	*	*	*	*	*	*	*	*	*
	9									*	*	*	*	*	*	*	*	*	*	*	*
	10										*	*	*	*	*	*	*	*	*	*	*
	11											*	*	*	*	*	*	*	*	*	*
	12												*	*	*	*	*	*	*	*	*
	13													*	*	*	*	*	*	*	*
	14														*	*	*	*	*	*	*
	15															*	*	*	*	*	*
	16																*	*	*	*	*
	17																		*	*	*
	18																				*

3.6 Practical Capacity of Selected Roads

It was observed from the traffic survey that other factors such as the highway conditions, traffic stream characteristics, traffic control devices and roadside activities contributed significantly to congestion on the highways. In computing the effect of these factors on the capacity of the road per lane in any direction of travel, equation 2.27 in Chapter 2 was modified to give equation 3.14 below.

$$C = V \left[\prod_i f_i - \frac{3}{80} (1 - k_c) \right] \quad (3.14)$$

where

C = Practical capacity

V = flow rate

k_c = congestion factor

f_i = adjustment for factor i

3.5.1 Determination of Adjustment Factors

1. Adjustment factor for highway conditions (f_1)

$$f_1 = W_e / W_d \quad (3.15)$$

W_e = effective lane width

This was the average width of each lane actually available for use by the motorists.

W_d = designed lane width

The designed lane width for all the roads was 3.65 m

2. Adjustment factor for traffic stream characteristics (f_2)

$$f_2 = 1 - (M + T) / 100 \quad (3.16)$$

M = percentage of motor-cycles in the traffic stream

T = percentage of tankers (3-axle or more) in the traffic stream

4. Adjustment factor for adequacy of traffic control devices (f_3)

A maximum value of 1 is assigned when effective and efficient traffic control devices are provided on the road.

$$f_3 = \begin{cases} 1 & \rightarrow \text{Adequate} \\ 0 < f_3 < 1 & \rightarrow \text{Inadequate/Few} \end{cases} \quad (3.17)$$

5. Adjustment factor for roadside activities including on-street parking (f_4)

A maximum value of 1 is assigned when there are no roadside activities such as mobile shops and on-street parking on the roadway.

$$f_4 = \begin{cases} 1 & \rightarrow \text{None} \\ 0 < f_4 < 1 & \rightarrow \text{activities} \end{cases} \quad (3.18)$$

3.7 Statistical Analysis

Non-parametric tests for differences between hyperbolic fit distributions of the observed and simulated headways were carried out using Kolmogorov-Smirnov goodness-of-fit test. The Kolmogorov-Smirnov test (KS-test) tries to determine if two data sets differ significantly (Oyawale, 2005). The KS-test has the advantage of making no assumption about the distribution of data. It is non-parametric and distribution free. Kolmogorov-Smirnov test is preferred because it is more efficient than the Chi-square test for small samples (Metcalf, 1997; Johnson, 2001).

Analysis of Variance (ANOVA) of the simulation results versus the field data were carried out with suitable statistical packages. The validation error was computed with equation 3.19.

$$e = \frac{\sum |c^{(sim)} - c^{(field)}|}{\sum c^{(field)}} \quad (3.19)$$

where C^{sim} and C^{field} are simulated and field capacities respectively. Brockfeld *et al.* (2004) and proposed that the absolute error a model produces is related to difference in simulated and observed traffic flow variable.



Plate 3.1. Sony HDR-HC3 Camcorder

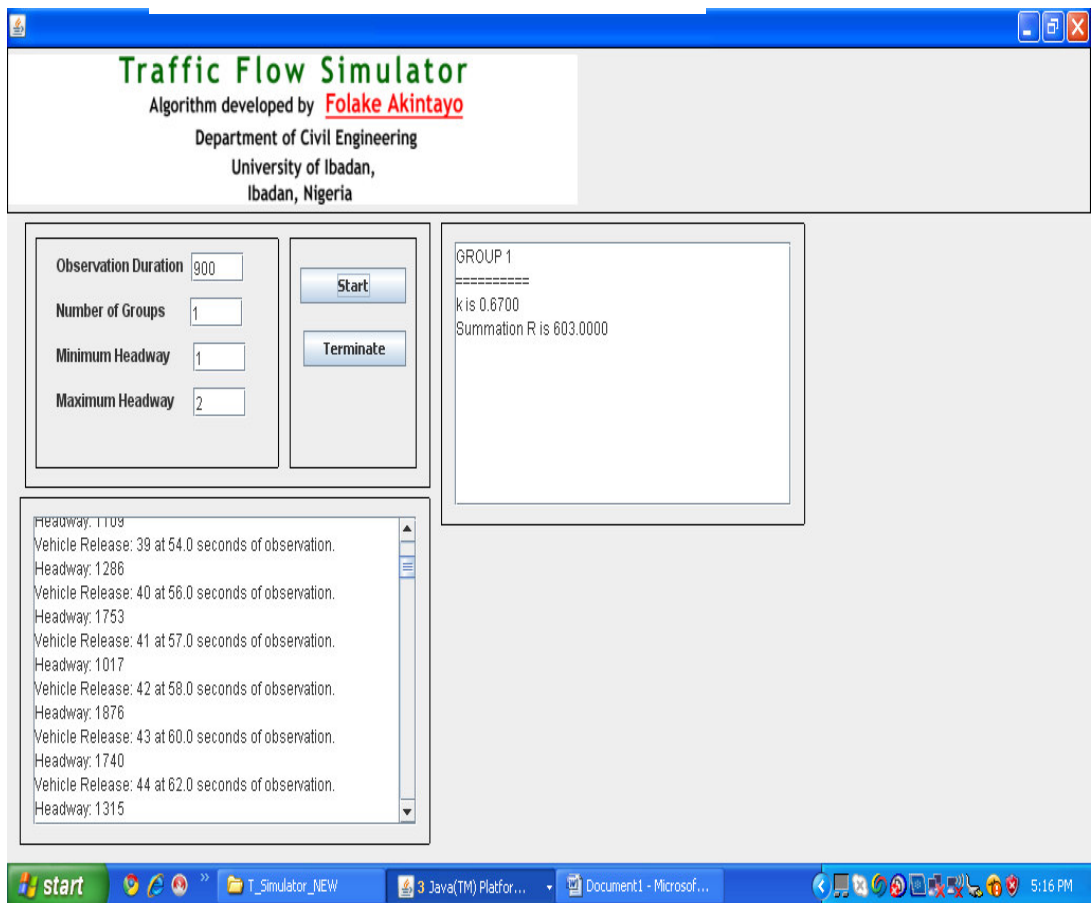

Plate 3.2. Traffic Flow Simulator Screen

CHAPTER 4

RESULTS AND DISCUSSIONS

4.1 Traffic Survey Results

4.1.1 General Summary

The summary of preliminary traffic survey has been categorised into three: roadway conditions; traffic stream compositions; and control devices as shown in Table 4.1. The visual assessment of the horizontal and vertical alignments of the roads under study showed no technical defects. The correctness of this assessment was demonstrated in the improvement scheme carried out on J Allen-Oke Bola after the conduct of the traffic survey: the horizontal alignment was maintained and; the new profile was kept close to the existing profile.

Road side activities such as on-road marketing, vulcanising and mobile shops for small businesses were visible on the shoulders of all the roads. On-street parking were also noticed on the three roads. Traffic streams consisted mainly of passenger cars although the proportion of motor cycles (11 %) is considered appreciable on J Allen-Oke Bola road. Traffic control was done mainly by the traffic wardens. Many of the road users disregarded the information conveyed by other traffic regulatory devices (markings and signs) on the roads.

Table 4.1: Summary of preliminary traffic survey

	Road	Name:	
	Total Garden- Agodi Gate	J Allen-Oke Bola	Odo Ona-Apata
Roadway Conditions:			
Number of Lanes	2	2	2
Lane width (m)	3.55	3.65	3.65
Effective lane width (m)	3.30	3.65	3.65
Shoulder width (m)	1.5	1.5	1.5
Lateral clearance	1.5	1.5	1.5
Design speed (km/h)	80	80	80
Horizontal alignment	OK	OK	OK
Vertical alignment	OK	OK	OK
Traffic stream composition (%):			
Motor-cycles	5	33	6
Cars	70	50	55
Commercial Buses	23	15	35
Tankers	2	2	4
Control Devices:			
Traffic light	None	None	None
Traffic signs	Few	Few	Few
Traffic markings	Few	Few	Few
Traffic regulations	Traffic Warden	Traffic Warden	Traffic Warden
Roadside activities:			
On-street business	Few	Few	Few
On-street parking	Few	Few	Few

4.1.2 Average traffic flow

The average vehicular flow was 715 ± 3 , 970 ± 5 and 1118 ± 9 vph per lane as shown in Table 4.2 for Total Garden-Agodi Gate, J Allen-Oke Bola and Odo Ona-Apata roads respectively.

Table 4.2: Average traffic flow on selected roads in vph

Period	Total Garden-Agodi Gate	J Allen-Oke Bola	Odo Ona-Apata
October 2008	712	970	1127
Nov. 2008	718	965	1105
Jan. 2009	716	977	1110
Feb. 2009	713	972	1123
March 2009	718	963	1125
April 2009	711	974	1120
Average Flow	715	970	1118
Standard Deviation	3	5	9

Generally, vehicular movements approached unstable state for traffic flows above 650 vph per lane for the three roads. In this state, drivers had little freedom to select their own speeds and there were frequent short stoppages. The unstable flows could be said to be fluctuating between LOS D and E as described in previous Table 2.4 in Chapter 2.

4.1.3 Field Headways

The minimum headway of field data ranged between 0.31 s and 0.40 s for approximated traffic flows between 700 and 1200 vph respectively. Average headway of 5.16 s was recorded at 700 vph and the lowest value of 2.98 s at 1200 vph as shown in Table 4.3. (See Appendix A2 for a typical set of extracted field headway data).

Table 4.3: Minimum and maximum values of field headway

Approximated Traffic flow (vph)	Minimum headway (s)	Maximum headway (s)	Average headway (s)
700	0.40	44.02	5.16
800	0.37	39.27	4.48
900	0.35	36.22	4.02
1000	0.34	35.17	3.61
1100	0.33	30.42	3.28
1200	0.31	22.11	2.98

The percentage compositions of the field headways are shown in Table 4.4. Five headway composition groups identified are:

- a. Group 1 - ($0.3 \leq h < 1$)
- b. Group 2 - ($1 \leq h < 2$)
- c. Group 3 - ($2 \leq h < 4$)
- d. Group 4 - ($4 \leq h < 10$)
- e. Group 5 - ($10 \leq h < 45$)

The percentage composition of each headway group per flow regime is as shown in Table 4.4. High percentage compositions of short headways were observed for all the flow regimes: 31.6 %, 31.7 % and 32.0 % for 700, 1000 and 1200 vph respectively for G2 ($1 < h < 2$). The same trend was observed in G3 and G4. Increased interaction between vehicles existed for G2, G3 and G4 due to the high percentage composition of short headways.

A representative headway distribution for the three roads is shown in Fig. 4.1.

Table 4.4: Percentage composition field headway per flow regime

Flow (vph)	$0.3 \leq h < 1$	$1 \leq h < 2$	$2 \leq h < 4$	$4 \leq h < 10$	$10 \leq h < 45$
700	12.4	27.1	31.5	19.8	9.1
800	12.2	31.2	25.4	22.2	9.0
900	8.8	30.9	24.5	27.5	8.3
1000	19.3	31.7	18.5	22.6	7.9
1100	8.9	36.4	26.7	21.8	6.2
1200	15.0	32.0	20.2	26.3	6.5

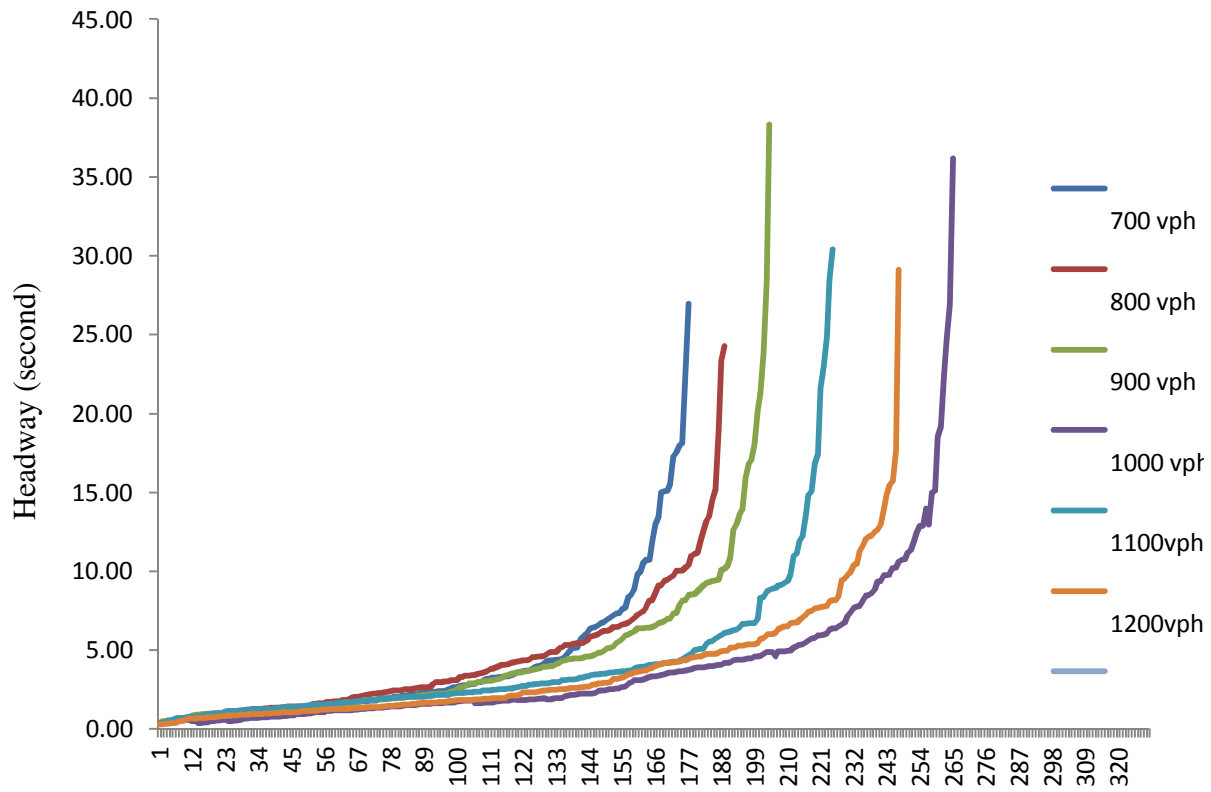

15-minute time interval data set

Fig. 4.1. Distribution field headway for flows between 700 to 1200 vph

4.2 Headway Modelling Output

4.2.1 Vehicular interaction

Following the stepwise procedure in Chapter 3, Sections 3.3.1 and 3.3.2, eighteen hyperbolic headway models to describe various percentiles of vehicular interactions for traffic flows ranging from 700 to 1200 vph for the three selected roads are shown in Table 4.5. The model was set at 0.1 second at zero percentile to indicate the minimum measurable value of headway with the equipment used in this study. As shown in Table 4.5, the highest coefficient of correlation ($R^2=0.92$) was recorded at 90 percentile while 0.18, 0.36, 0.50, 0.71, 0.82, and 0.79 were obtained at 1, 10, 30, 50, and 100 percentile respectively.

The adjustment factor, A at each flow level computed with equation 3.9 is shown in Table 4.6. Its value decreases with increasing flow rate: 0.9982, 0.9941, 0.9901, 0.9861, 0.9822 and 0.9783 for 700, 800, 900, 1000, 1100 and 1200 vph respectively. The developed cumulative headway spreadsheet for traffic flows ranging from 700 to 1200 vph for two-lane highways is shown in Table 4.7 and the cumulative graph in fig. 4.2.

Detail output of the modelling process is in Appendix B.

Table 4.5: Hyperbolic headway simulation models

	Cumulative Percentage	Hyperbolic Model	Coefficient of Correlation (R²)
-	0	0.1	0
1	1	$H=91.263/V+0.2627$	0.1799
2	2	$H=125.86/V+0.2718$	0.2159
3	3	$H=196.67/V+0.2552$	0.2245
4	4	$H=246.41/V+0.2577$	0.2629
5	5	$H=291.56/V+0.2712$	0.2811
6	10	$H=398.2/V+0.4201$	0.3572
7	20	$H=278.9/V+0.8835$	0.4292
8	30	$H=424.03/V+1.0777$	0.5002
9	40	$H=581.48/V+1.1976$	0.6024
10	50	$H=1416.8/V+0.8055$	0.7118
11	60	$H=1173.9/V+1.8482$	0.7652
12	70	$H=823.78/V+2.8909$	0.8234
13	80	$H=3423.1/V+2.7752$	0.9038
14	90	$H=2967.5/V+5.7599$	0.9164
15	95	$H=39530/V-25.205$	0.8753
16	98	$H=41819/V-21.36$	0.8462
17	99	$H=44435/V-19.172$	0.8254
18	100	$H=37993/V-9.8272$	0.7947

Table 4.6: Hyperbolic model adjustment factors

Volume	Av_hrly Vol headway	Av_Hyperbolic Headway	Adjustment Factor
700	5.1429	5.1521	0.9982
710	5.0704	5.0816	0.9978
720	5.0000	5.0131	0.9974
730	4.9315	4.9464	0.9970
740	4.8649	4.8816	0.9966
750	4.8000	4.8185	0.9962
760	4.7368	4.7570	0.9958
770	4.6753	4.6971	0.9954
780	4.6154	4.6388	0.9950
790	4.5570	4.5820	0.9945
800	4.5000	4.5265	0.9941
810	4.4444	4.4725	0.9937
820	4.3902	4.4197	0.9933
830	4.3373	4.3682	0.9929
840	4.2857	4.3180	0.9925
850	4.2353	4.2689	0.9921
860	4.1860	4.2210	0.9917
870	4.1379	4.1742	0.9913
880	4.0909	4.1284	0.9909
890	4.0449	4.0837	0.9905
900	4.0000	4.0400	0.9901
910	3.9560	3.9972	0.9897
920	3.9130	3.9553	0.9893
930	3.8710	3.9144	0.9889
940	3.8298	3.8743	0.9885
950	3.7895	3.8351	0.9881
960	3.7500	3.7967	0.9877
970	3.7113	3.7590	0.9873
980	3.6735	3.7222	0.9869
990	3.6364	3.6861	0.9865
1000	3.6000	3.6507	0.9861
1010	3.5644	3.6184	0.9851
1020	3.5294	3.5820	0.9853
1030	3.4951	3.5487	0.9849
1040	3.4615	3.5159	0.9845
1050	3.4286	3.4839	0.9841
1060	3.3962	3.4524	0.9837
1070	3.3645	3.4215	0.9833
1080	3.3333	3.3912	0.9829
1090	3.3028	3.3614	0.9826
1100	3.2727	3.3322	0.9822
1110	3.2432	3.3058	0.9811
1120	3.2143	3.2753	0.9814
1130	3.1858	3.2477	0.9810
1140	3.1579	3.2205	0.9806
1150	3.1304	3.1937	0.9802
1160	3.1034	3.1675	0.9798
1170	3.0769	3.1417	0.9794
1180	3.0508	3.1163	0.9790
1190	3.0252	3.0913	0.9786
1200	3.0000	3.0665	0.9783

Table 4.7: Cumulative headway distribution spreadsheet for traffic flows between 700 and 1200 vph

Traffic Volume Interval	Traffic Volume	Cumulative Percentage																		
		0	1	2	3	4	5	10	20	30	40	50	60	70	80	90	95	98	99	100
700-710	705	0.10	0.43	0.52	0.56	0.62	0.71	0.99	1.34	1.71	2.13	2.90	4.00	4.96	7.14	11.26	15.85	26.92	34.75	41.64
711-720	715	0.10	0.43	0.51	0.55	0.62	0.71	0.99	1.33	1.70	2.11	2.87	3.94	4.90	7.04	11.09	15.64	26.39	34.04	40.93
721-730	725	0.10	0.42	0.51	0.55	0.62	0.71	0.98	1.33	1.69	2.10	2.84	3.89	4.85	6.95	10.93	15.43	25.88	33.35	40.23
731-740	735	0.10	0.42	0.50	0.55	0.61	0.70	0.98	1.32	1.67	2.08	2.80	3.84	4.79	6.86	10.77	15.22	25.38	32.68	39.56
741-750	745	0.10	0.42	0.50	0.54	0.61	0.70	0.97	1.31	1.66	2.06	2.77	3.79	4.74	6.77	10.62	15.02	24.89	32.02	38.90
751-760	755	0.10	0.42	0.50	0.54	0.61	0.70	0.96	1.30	1.65	2.05	2.75	3.75	4.69	6.68	10.47	14.82	24.41	31.39	38.26
761-770	765	0.10	0.41	0.49	0.54	0.60	0.69	0.96	1.30	1.63	2.03	2.72	3.70	4.64	6.59	10.32	14.64	23.95	30.77	37.64
771-780	775	0.10	0.41	0.49	0.53	0.60	0.69	0.95	1.29	1.62	2.01	2.69	3.65	4.59	6.51	10.18	14.45	23.50	30.17	37.03
781-790	785	0.10	0.41	0.49	0.53	0.60	0.69	0.95	1.28	1.61	2.00	2.66	3.61	4.54	6.43	10.04	14.27	23.06	29.58	36.44
791-800	795	0.10	0.41	0.48	0.53	0.60	0.68	0.94	1.28	1.60	1.98	2.64	3.57	4.50	6.35	9.90	14.09	22.63	29.00	35.86
801-810	805	0.10	0.41	0.48	0.53	0.59	0.68	0.94	1.27	1.59	1.97	2.61	3.53	4.45	6.27	9.77	13.92	22.21	28.45	35.30
811-820	812	0.10	0.40	0.48	0.52	0.59	0.68	0.93	1.26	1.58	1.96	2.59	3.50	4.42	6.22	9.68	13.80	21.93	28.06	34.91
821-830	825	0.10	0.40	0.47	0.52	0.59	0.68	0.93	1.26	1.57	1.94	2.56	3.44	4.36	6.12	9.52	13.59	21.41	27.37	34.22
831-840	835	0.10	0.40	0.47	0.52	0.59	0.67	0.92	1.25	1.56	1.93	2.54	3.41	4.32	6.05	9.40	13.43	21.02	26.85	33.69
841-850	845	0.10	0.40	0.47	0.52	0.58	0.67	0.92	1.24	1.55	1.91	2.51	3.37	4.28	5.98	9.28	13.28	20.64	26.35	33.18
851-860	852	0.10	0.40	0.46	0.51	0.58	0.67	0.92	1.24	1.54	1.90	2.50	3.34	4.25	5.93	9.20	13.17	20.39	26.00	32.83
861-870	865	0.10	0.39	0.46	0.51	0.58	0.67	0.91	1.23	1.53	1.89	2.47	3.30	4.20	5.84	9.05	12.98	19.92	25.37	32.20
871-880	875	0.10	0.39	0.46	0.51	0.58	0.66	0.91	1.23	1.52	1.88	2.45	3.26	4.16	5.78	8.94	12.83	19.56	24.90	31.73
881-890	885	0.10	0.39	0.45	0.51	0.57	0.66	0.90	1.22	1.51	1.86	2.43	3.23	4.13	5.71	8.83	12.69	19.22	24.44	31.26
891-900	900	0.10	0.39	0.45	0.50	0.57	0.66	0.90	1.21	1.49	1.85	2.40	3.17	4.07	5.62	8.67	12.48	18.72	23.77	30.58
901-910	905	0.10	0.39	0.45	0.50	0.57	0.66	0.89	1.21	1.49	1.84	2.39	3.16	4.05	5.59	8.62	12.42	18.56	23.55	30.37
911-920	915	0.10	0.39	0.45	0.50	0.57	0.65	0.89	1.20	1.48	1.83	2.37	3.13	4.02	5.53	8.52	12.29	18.23	23.12	29.93
921-930	925	0.10	0.38	0.44	0.50	0.57	0.65	0.89	1.20	1.47	1.82	2.35	3.09	3.98	5.47	8.42	12.16	17.92	22.70	29.51
931-940	935	0.10	0.38	0.44	0.49	0.56	0.65	0.88	1.19	1.46	1.81	2.33	3.06	3.95	5.41	8.32	12.03	17.61	22.29	29.09
941-950	945	0.10	0.38	0.44	0.49	0.56	0.65	0.88	1.19	1.45	1.80	2.31	3.03	3.92	5.36	8.23	11.91	17.31	21.89	28.69
951-960	955	0.10	0.38	0.44	0.49	0.56	0.64	0.88	1.18	1.45	1.79	2.29	3.00	3.88	5.30	8.13	11.78	17.02	21.49	28.29
961-970	965	0.10	0.38	0.43	0.49	0.56	0.64	0.87	1.18	1.44	1.78	2.27	2.97	3.85	5.25	8.04	11.66	16.73	21.11	27.90

Traffic Volume Interval	Traffic Volume	0	1	2	3	4	5	10	20	30	40	50	60	70	80	90	95	98	99	100
971-980	975	0.10	0.38	0.43	0.49	0.56	0.64	0.87	1.18	1.43	1.77	2.25	2.95	3.82	5.20	7.95	11.55	16.45	20.73	27.52
981-990	988	0.10	0.37	0.43	0.48	0.55	0.64	0.86	1.17	1.42	1.75	2.23	2.91	3.78	5.13	7.84	11.40	16.09	20.25	27.03
1011-1020	1015	0.10	0.37	0.42	0.48	0.55	0.63	0.86	1.16	1.40	1.73	2.19	2.84	3.70	4.99	7.61	11.10	15.37	19.29	26.06
1021-1030	1025	0.10	0.37	0.42	0.48	0.55	0.63	0.85	1.15	1.39	1.72	2.17	2.81	3.68	4.95	7.53	11.00	15.12	18.95	25.73
1031-1040	1035	0.10	0.37	0.42	0.48	0.55	0.63	0.85	1.15	1.39	1.71	2.16	2.79	3.65	4.90	7.45	10.90	14.87	18.62	25.39
1041-1050	1045	0.10	0.37	0.42	0.47	0.54	0.63	0.85	1.15	1.38	1.70	2.14	2.76	3.62	4.86	7.38	10.79	14.62	18.29	25.06
1051-1060	1055	0.10	0.36	0.41	0.47	0.54	0.63	0.84	1.14	1.37	1.69	2.13	2.74	3.60	4.81	7.30	10.70	14.38	17.97	24.73
1061-1070	1065	0.10	0.36	0.41	0.47	0.54	0.62	0.84	1.14	1.37	1.68	2.11	2.71	3.57	4.77	7.22	10.60	14.15	17.66	24.41
1071-1080	1075	0.10	0.36	0.41	0.47	0.54	0.62	0.84	1.13	1.36	1.68	2.10	2.69	3.54	4.72	7.15	10.50	13.92	17.35	24.10
1081-1090	1085	0.10	0.36	0.41	0.47	0.54	0.62	0.83	1.13	1.35	1.67	2.08	2.67	3.52	4.68	7.08	10.41	13.69	17.04	23.80
1091-1100	1095	0.10	0.36	0.40	0.46	0.54	0.62	0.83	1.13	1.35	1.66	2.06	2.64	3.48	4.62	6.98	10.27	13.36	16.61	23.35
1101-1110	1108	0.10	0.36	0.40	0.46	0.53	0.62	0.83	1.12	1.34	1.65	2.05	2.61	3.46	4.58	6.90	10.18	13.13	16.30	23.04
1111-1120	1115	0.10	0.36	0.40	0.46	0.53	0.62	0.83	1.12	1.34	1.64	2.04	2.60	3.45	4.56	6.87	10.13	13.03	16.16	22.90
1121-1130	1125	0.10	0.36	0.40	0.46	0.53	0.61	0.82	1.12	1.33	1.64	2.03	2.58	3.42	4.52	6.80	10.05	12.82	15.89	22.62
1131-1140	1135	0.10	0.36	0.40	0.46	0.53	0.61	0.82	1.11	1.32	1.63	2.02	2.56	3.40	4.48	6.74	9.96	12.62	15.61	22.34
1141-1150	1145	0.10	0.35	0.40	0.46	0.53	0.61	0.82	1.11	1.32	1.62	2.00	2.54	3.38	4.44	6.67	9.88	12.41	15.34	22.07
1151-1160	1155	0.10	0.35	0.39	0.46	0.53	0.61	0.82	1.11	1.31	1.62	1.99	2.52	3.36	4.40	6.61	9.80	12.21	15.07	21.80
1161-1170	1165	0.10	0.35	0.39	0.45	0.53	0.61	0.81	1.10	1.31	1.61	1.98	2.50	3.33	4.37	6.55	9.71	12.02	14.81	21.53
1171-1180	1175	0.10	0.35	0.39	0.45	0.53	0.61	0.81	1.10	1.30	1.60	1.97	2.48	3.31	4.33	6.49	9.63	11.83	14.55	21.27
1181-1190	1185	0.10	0.35	0.39	0.45	0.52	0.60	0.81	1.10	1.30	1.59	1.95	2.46	3.29	4.29	6.43	9.56	11.64	14.30	21.02
1191-1200	1195	0.10	0.35	0.39	0.45	0.52	0.60	0.81	1.09	1.29	1.59	1.94	2.44	3.27	4.26	6.37	9.48	11.45	14.05	20.76

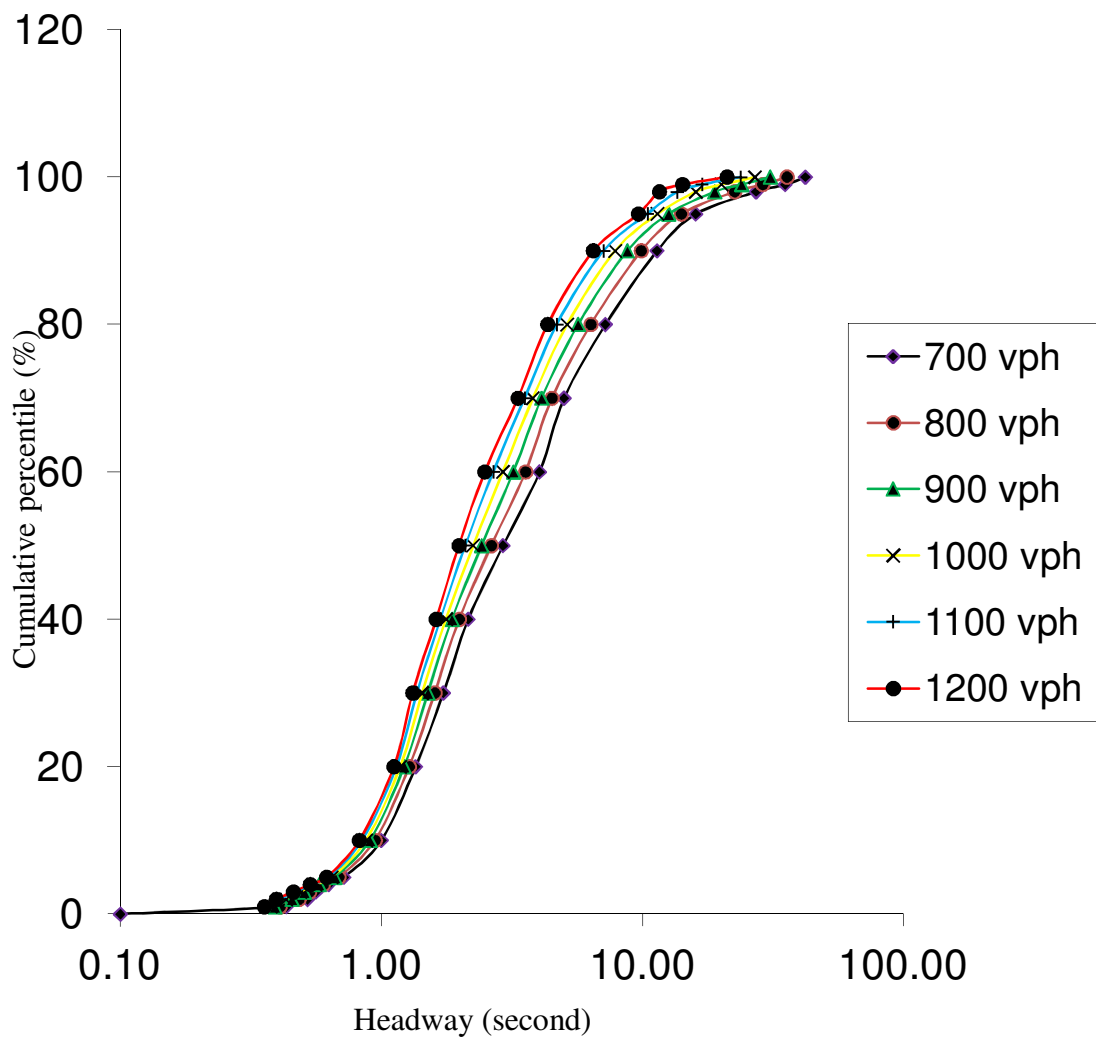

Fig. 4.2. Cumulative headway distributions of traffic flows between 700 to 1200 vph

4.2.2 Comparison of theoretical and field headways

The field and simulation headway results extracted from Table 4.7 for the three roads were compared using Kolmogorov-Smirnov (KS) test. The detail of the statistical analysis with Kolmogorov-Smirnov (KS) test is given in Appendix C and the summary shown in Table 4.8. The graphical illustrations of the comparison are shown in figs. C1.2 to C1.5.

The maximum difference between the cumulative distributions (D) was 0.16 and corresponding probability of acceptance (P) being equal to 1.00 for flow rate of 900 vph. The minimum value of D was 0.05 and $P = 1.00$ for flow rate of 1000 vph. The KS test showed that the distributions of headways on the roads were consistent with log normal distributions.

The result of the test showed that Table 4.7 can be used (with adjustments if necessary) to generate design parameters for two-lane highways of traffic stream characteristics as the roads studied.

Table 4.8: Kolmogorov-Smirnov test result

Approximate field flow	D observed	Probability of Acceptance	Remarks
700	0.1053	1.000	Accept
800	0.1053	1.000	Accept
900	0.1579	0.956	Accept
1000	0.0526	0.949	Accept
1100	0.0526	1.000	Accept

4.3 Traffic Flow Analysis

4.3.1 Simulated traffic flows

The simulated traffic flows generated with the traffic flow simulator (TRAFLOS) are shown in Table 4.8 using the experimental design of Table 3.1 in Chapter 3. The detailed output of flows simulated with minimum and maximum headways of 1 and 2 seconds; 1 and 3 seconds respectively are contained in Appendix D.

The service flow rates computed with equation 3.13 are shown in Table 4.10. The simulated flow distribution is logarithmic as illustrated in figs. 4.3 for scenarios generated with minimum headway of 1 second.

Table 4.9: Simulated Traffic Volume for Different Congestion Scenarios

		Maximum Headway (seconds)																	
		1	2	3	4	5	6	7	8	9	10	11	12	13	14	15	16	17	18
Minimum Headway (seconds)	1	900	594	450	360	305	250	242	204	172	174	150	145	136	120	104	104	105	92
	2	0	450	358	297	255	222	201	177	167	155	141	142	116	113	109	98	88	91
	3	0	0	300	254	225	193	179	174	149	134	131	116	112	105	102	89	91	85
	4	0	0	0	225	195	176	163	147	142	126	114	110	106	98	98	89	83	85
	5	0	0	0	0	180	163	149	135	128	115	115	104	102	93	86	82	83	80
	6	0	0	0	0	0	150	138	128	120	110	107	106	91	88	81	82	81	74
	7	0	0	0	0	0	0	128	119	112	105	99	93	88	84	82	79	76	69
	8	0	0	0	0	0	0	0	112	106	99	94	90	86	80	78	74	70	68
	9	0	0	0	0	0	0	0	0	100	95	88	86	83	79	76	72	68	68
	10	0	0	0	0	0	0	0	0	0	90	85	81	78	75	71	69	66	61
	11	0	0	0	0	0	0	0	0	0	0	81	78	75	71	68	66	65	61
	12	0	0	0	0	0	0	0	0	0	0	0	75	71	68	67	63	62	61
	13	0	0	0	0	0	0	0	0	0	0	0	0	69	66	66	62	59	57
	14	0	0	0	0	0	0	0	0	0	0	0	0	0	64	61	59	58	56
	15	0	0	0	0	0	0	0	0	0	0	0	0	0	0	60	57	55	54
	16	0	0	0	0	0	0	0	0	0	0	0	0	0	0	0	56	54	53
	17	0	0	0	0	0	0	0	0	0	0	0	0	0	0	0	0	52	51
	18	0	0	0	0	0	0	0	0	0	0	0	0	0	0	0	0	0	50

Table 4.10: Computed flow rates for different congestion scenarios

		Maximum Headway (seconds)																	
		1	2	3	4	5	6	7	8	9	10	11	12	13	14	15	16	17	18
Minimum Headway (seconds)	1	3600	2376	1800	1440	1220	1000	968	816	688	696	600	580	544	480	416	416	420	368
	2	0	1800	1432	1188	1020	888	804	708	668	620	564	568	464	452	436	392	352	364
	3	0	0	1200	1016	900	772	716	696	596	536	524	464	448	420	408	356	364	340
	4	0	0	0	900	780	704	652	588	568	504	456	440	424	392	392	356	332	340
	5	0	0	0	0	720	652	596	540	512	460	460	416	408	372	344	328	332	320
	6	0	0	0	0	0	600	552	512	480	440	428	424	364	352	324	328	324	296
	7	0	0	0	0	0	0	512	476	448	420	396	372	352	336	328	316	304	276
	8	0	0	0	0	0	0	0	448	424	396	376	360	344	320	312	296	280	272
	9	0	0	0	0	0	0	0	0	400	380	352	344	332	316	304	288	272	272
	10	0	0	0	0	0	0	0	0	0	360	340	324	312	300	284	276	264	244
	11	0	0	0	0	0	0	0	0	0	0	324	312	300	284	272	264	260	244
	12	0	0	0	0	0	0	0	0	0	0	0	300	284	272	268	252	248	244
	13	0	0	0	0	0	0	0	0	0	0	0	0	276	264	264	248	236	228
	14	0	0	0	0	0	0	0	0	0	0	0	0	0	256	244	236	232	224
	15	0	0	0	0	0	0	0	0	0	0	0	0	0	0	240	228	220	216
	16	0	0	0	0	0	0	0	0	0	0	0	0	0	0	0	224	216	212
	17	0	0	0	0	0	0	0	0	0	0	0	0	0	0	0	0	208	204
	18	0	0	0	0	0	0	0	0	0	0	0	0	0	0	0	0	0	200

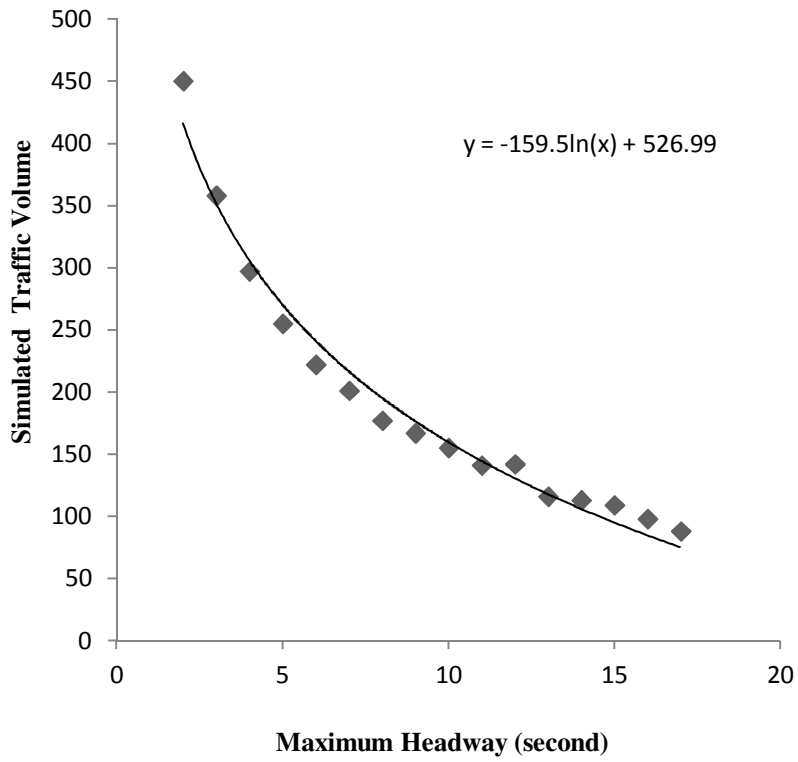

Fig. 4.3. Distribution of simulated flows with minimum headway of 1 second

4.3.2 Congestion factors

The congestion factor for each scenario was computed with equation 3.13 and tabulated as shown in Table 4.11. The highest congestion factor ($k_c=1$) was computed for Scenario_{1,1}. This was a case of traffic jam, a scenario where vehicles arrived bumper to bumper at the observation point. For $S_{1,2}$; $S_{1,3}$; $S_{1,4}$; and progressively to $S_{1,18}$; k_c reduced to 0.66, 0.50, 0.40 and 0.10 respectively. This was the pattern of the scenarios at any level of minimum or maximum headway.

The congestion factor increased linearly with increased flow rate as illustrated in fig. 4.4. The congestion factor corresponding to different level of service based on the traffic survey conducted is shown in Table 4.12.

Table 4.11: Computed Congestion Factors for Different Congestion Scenarios

Scenario	Congestion factor, k_c :																	
	1	2	3	4	5	6	7	8	9	10	11	12	13	14	15	16	17	18
1	1.00	0.66	0.50	0.40	0.34	0.28	0.27	0.23	0.19	0.19	0.17	0.16	0.15	0.13	0.12	0.12	0.12	0.10
2		0.50	0.40	0.33	0.28	0.25	0.22	0.20	0.19	0.17	0.16	0.16	0.13	0.13	0.12	0.11	0.10	0.10
3			0.33	0.28	0.25	0.21	0.20	0.19	0.17	0.15	0.15	0.13	0.12	0.12	0.11	0.10	0.10	0.09
4				0.25	0.22	0.20	0.18	0.16	0.16	0.14	0.13	0.12	0.12	0.11	0.11	0.10	0.09	0.09
5					0.20	0.18	0.17	0.15	0.14	0.13	0.13	0.12	0.11	0.10	0.10	0.09	0.09	0.09
6						0.17	0.15	0.14	0.13	0.12	0.12	0.12	0.10	0.10	0.09	0.09	0.09	0.08
7							0.14	0.13	0.12	0.12	0.11	0.10	0.10	0.09	0.09	0.09	0.08	0.08
8								0.12	0.12	0.11	0.10	0.10	0.10	0.09	0.09	0.08	0.08	0.08
9									0.11	0.11	0.10	0.10	0.09	0.09	0.08	0.08	0.08	0.08
10										0.10	0.09	0.09	0.09	0.08	0.08	0.08	0.07	0.07
11											0.09	0.09	0.08	0.08	0.08	0.07	0.07	0.07
12												0.08	0.08	0.08	0.07	0.07	0.07	0.07
13													0.08	0.07	0.07	0.07	0.07	0.06
14														0.07	0.07	0.07	0.06	0.06
15															0.07	0.06	0.06	0.06
16																0.06	0.06	0.06
17																	0.06	0.06
18																		0.06

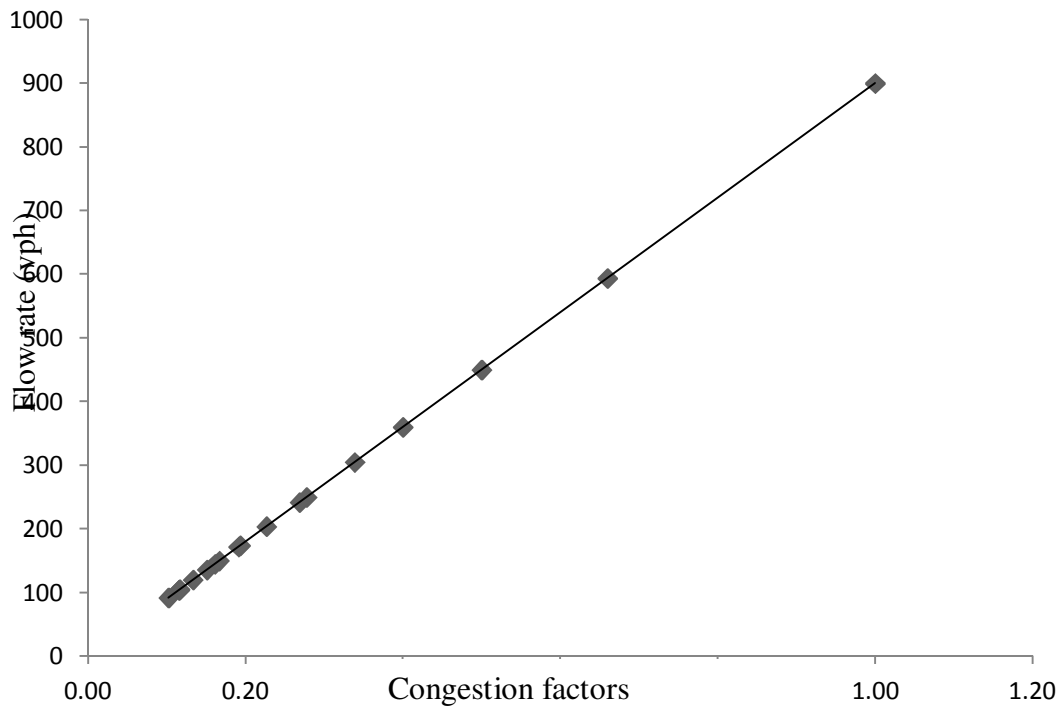

Fig. 4.4 Congestion factors for simulated flows

Table 4.12: Congestion factors and equivalent level of service

Congestion Factor, k_c	Level of Service
0.1	A
0.2	B
0.3	C
0.4	D
0.5	D
0.6	D
0.7	E
0.8	E
0.9	F
1.0	F

4.3.3 Capacity adjustment

The capacity adjustment factors for each road based on the prevailing conditions at the time of this study are shown in Table 4.12. Odo Ona-Apata had the highest overall performance value of approximately 0.801 which is equivalent to 20 % congestion. The high percentage of motor-cycles on J Allen Oke Bola road (12 %) contributed to impedance of vehicular traffic flow.

Table 4.13: Capacity adjustment factors

	Total Garden- Agodi Gate	J Allen-Oke Bola	Odo Ona-Apata
Adjustment factors: f_1	0.97	1.00	1.00
f_2	0.93	0.87	0.90
f_3	0.92	0.95	0.91
f_4	0.93	0.96	0.98
$\prod_i f_i$	0.771	0.796	0.801

4.3.4 Capacity Analysis for different congestion scenarios

The traffic flows at different percentiles of vehicular interaction were evaluated with predefined congestion factors depicting different scenarios of congestion. Starting from 30 to 100 percentile, approximated headways for average flow rate of each road were extracted from Table 4.7. Equivalent simulated flows were extracted from Table 4.10. The analysis at the highest congestion level, $k_c = 1$ (see Table 4.11) for the three roads are shown in Tables 4.14 to 4.16.

The capacity of Total Garden-Agodi Gate was evaluated with headway of 3 seconds corresponding to the highest percentage of field headway (31.5 %) in the traffic stream as shown in Table 4.4. The analysis was carried out with headway of 2 seconds having highest percentage composition of 31.2 % and 36.4 % for J Allen-Oke Bola and Odo Ona-Apata respectively.

The capacity analysis produced approximated maximum flow rates of 1850, 2865 and 2881 vph in the two directions of travel for Total Garden-Agodi Gate, J Allen-Oke Bola and Odo Ona-Apata roads respectively. The capacity of Total Garden-Agodi Gate was within the recommended maximum value of 2800 vph (see Chapter 2, Table 2.6) in the two directions of travel for two-lane highways.

Table 4.14: Capacity Analysis of Total Garden-Agodi Gate Road for $k_c = 1$

Percentile Interaction	Approximated Headway (s)	Simulated Flow (vph)	Capacity
30	2	1800	1388
40	2	1800	1388
50	3	1200	925
60	4	900	694
70	5	720	555
80	7	512	395
90	11	324	250
95	16	224	
98	27		
99	35		
100	42		

Road capacity per lane = 925

= 1850 in the two directions of travel.

Table 4.15: Capacity Analysis of J Allen-Oke Bola Road for $k_c = 1$

Percentile	Approximated	Simulated	Capacity
Interaction	Headway (s)	Flow (vph)	
30	1	3600	2866
40	2	1800	1432
50	2	1800	1432
60	3	1200	955
70	4	900	716
80	5	720	573
90	8	448	357
95	12	300	239
98	17	208	166
99	21		
100	28		

Road capacity per lane = 1432

= 2865 in the two directions of travel.

Table 4.16: Capacity Analysis of Odo Ona-Apata Road for $k_c = 1$

Percentile Interaction	Approximated Headway (s)	Simulated Flow (vph)	Capacity
30	1	3600	2884
40	2	1800	1441
50	2	1800	1441
60	3	1200	961
70	3	900	721
80	5	720	577
90	7	512	410
95	10	360	288
98	13	276	221
99	16	224	179
100	23		

Road capacity per lane = 1441

= 2881 in the two directions of travel.

The simulated and field capacities for the three roads at different congestion levels are given in Table 4.17 to 4.19.

Table 4.17: Simulated capacities at different congestion levels for Total Garden-Agodi Gate

Congestion factor, kc	Simulated Capacity	Field Capacity
0.1	1769	1587
0.2	1778	1668
0.3	1787	1724
0.4	1796	1751
0.5	1805	1799
0.6	1814	1822
0.7	1823	1901
0.8	1832	1927
0.9	1841	1954
1	1850	2101

Table 4.18: Simulated capacities at different congestion levels for J Allen-Agodi Gate road

Congestion factor, kc	Simulated Capacity	Field Capacity
0.1	2743	2730
0.2	2757	2741
0.3	2770	2681
0.4	2784	2749
0.5	2797	2762
0.6	2811	2815
0.7	2824	2843
0.8	2838	2867
0.9	2851	2875
1	2865	2887

Table 4.19: Simulated capacities at different congestion levels for Odo Ona-Apata road

Congestion factor, kc	Simulated Capacity	Field Capacity
0.1	2760	2732
0.2	2773	2766
0.3	2787	2741
0.4	2800	2788
0.5	2814	2811
0.6	2827	2837
0.7	2841	2855
0.8	2854	2867
0.9	2868	2872
1	2881	2890

4.3.5 Results of the Analysis of Variance (ANOVA) test

The One-Way ANOVA test established that there was no significant difference between the field capacity and the capacity generated by the models developed in this study. The summary of the test is given in Table 4.18 below and the details in Appendix E. The highest probability of acceptance ($P = 0.84$) of the models was recorded for the analysis of traffic flow on Odo Ona-Apata road which also had the highest overall performance of 0.80 as shown in Table 4.13. The models also performed well for Total Garden-Agodi Gate and J Allen-Oke Bola roads with $P = 0.78$ and 0.73 respectively.

Table 4.20: ANOVA test result for differences in simulated and field capacities

	Total Garden- Agodi Gate	J Allen- Oke Bola	Odo Ona- Apata
Average capacity:			
(Models)	1810	2804	2821
(Field)	1823	2795	2816
F	0.08	0.11	0.04
F_{cr}	4.41	4.41	4.41
P	0.78	0.73	0.84

4.3.6 Validation of Models for J Allen-Oke Bola Road

The dualisation of Obafemi Awolowo road was completed in year 2010. Validation data for the models developed in this study were collected in February 2011 on J Allen-Oke Bola Road (a segment of Obafemi Awolowo road).

The performance value of the road had increased to about 1.55 and reduced traffic congestion by about 55 % as shown in Table 4.19. It was assumed that the two lanes in each direction of flow acted as one lane of width 7.30 m since the lanes were undivided. In this case the adjustment for highway conditions (lane width) was computed to be 2. The percentage of motor-cycles in the traffic stream had increased to 14 %. Road side activities reduced slightly due to the presence of the Oyo State Road Management team.

Table 4.21: Capacity adjustment factors for dualised J Allen-Oke Bola road

Adjustment factors: f_1	2.00
f_2	0.84
f_3	0.95
f_4	0.97
$\prod_i f_i$	1.55
Congestion Reduction = (1.55-1.0)	
= 55 %	

4.3.7 Validation errors

The validation error at each congestion level was computed with equation 3.19. A maximum validation error of 35.0 % was obtained with congestion factor of 1 as shown in Table 4.20.

Table 4.22: Capacity Analysis of dualised J Allen-Oke Bola Road

Congestion Factor	Simulated	Field	Error (%)
0.1	2726	2240	21.7
0.2	2732	2249	21.5
0.3	2739	2207	24.1
0.4	2746	2186	25.6
0.5	2753	2164	27.2
0.6	2759	2162	27.6
0.7	2766	2144	29.0
0.8	2773	2099	32.1
0.9	2780	2078	33.8
1	2786	2064	35.0

CHAPTER 5

CONCLUSION AND RECOMMENDATION

5.1 Conclusion

The specific contribution to knowledge in this study is the formulation of a rational procedure for minimising highway traffic congestion using germane traffic parameters such as headway and traffic flow. The hyperbolic models developed to represent and replicate these parameters showed fairly good fits near the minimum, the middle and the maximum range of traffic volumes ranging from 700 to 1200 pcu per lane on two-lane highways characterised by heavy traffic. The mechanisms for traffic flow enhancement and congestion reduction on two-lane highways were also evolved.

The following conclusion can be drawn from the application of the rational procedure formulated in this study on the selected three roads studied in the Ibadan metropolis:

- The hyperbolic models approximated headway distribution of the traffic flows.
- The cumulative headway distribution spreadsheet developed for traffic flow ranging between 700 to 1200 vph can also be used for traffic flow analysis of other roads in the metropolis with similar traffic stream characteristics.
- The traffic flow simulator developed successfully simulated the traffic situations on the selected roads.
- Quantification of the conditions of the roads and integrating them into capacity evaluation models.
- The capacity analysis of the flow yielded results that could ameliorate traffic congestion on the roads.

In addition, information derived from the headway data collected for the roads are useful in predicting arrival patterns of vehicles at strategic points on the roadways, testing the randomness of traffic flow, and for the overall efficient and effective management of traffic on the roads.

5.2 Recommendation

There is a need for a computerised traffic data collection system to improve the quality of traffic flow researches in Nigeria.

REFERENCES

- Abul-Magd, A.Y. 2007. Modelling highway-traffic headway distributions using superstatistics. *Physical Review E* 76.5:1-30
- Ackoff, R. L. and Sasieni, M. W. 1986. *Fundamentals of Operations Research*. New Delhi: Wiley Eastern Limited.
- Adams, W. F. 1936. Road traffic considered as a random series. *Journal of Institution of Civil Engineers* 4: 121-130.
- Adebisi, O. and Chiejina, E. 1983. Travel time characteristics of conventional intr-urban bus in Kaduna. *The Nigerian Engineer* 18.3: 81-88.
- Agbede, O. A. 1996. Groundwater modelling - an overview. *Journal of Mining and Geology* 32.2:10-112.
- Agbede, O. A. and Adegbola, A. A. 2003. Application of the numerical modelling techniques to the simulation of groundwater flow in the Gwandu formation of the north-western Nigeria basin. *Journal of Applied Science and Technology* 3.1: 13-18.
- Akanbi O. G., Charles-Owaba O. E. and Oluleye A. E. 2009. Human factors in traffic accidents in Lagos, Nigeria. *Disaster Prevention and Management* 18.4:397-409.
- Akcelik, R. and Chung, E. 1994. Calibration of the bunched exponential distribution of arrival headways. *Road and Transport Research* 3.1: 42-59.
- Akintayo, F. O. and Agbede O. A. 2009. Headway distribution modelling of free-flowing traffic on two-lane single carriageways in Ibadan. *Proceedings of the 1st International Conference on the Role of Engineering and Technology in Achieving Vision 20:2020 –RETAV 2009* (17– 19 Nov., 2009), Obafemi Awolowo University, Ile-Ife, Nigeria: 240-246.
- Andrew, D., 2004. The world's worst traffic jams. *Time magazine*. Retrieved on 10/06/2009
- Arasan, V. T. and Arkatkar, S. S. 2010. Modelling heterogeneous traffic flow on upgrades of intercity roads. *Transport* 25.2: 129-137.
- Arasan, V. T. and Koshy, R. Z. 2003. Headway distribution of heterogeneous traffic on urban arterials. *Journal of the Institution of Engineers (India)* 84: 210-215.

- Asalor, J. O., Onibere, E. A. and Ovuworie, G. C. 1986. Road traffic accidents in developing countries. *Proceedings of the 1st International Conference (4– 6 August, 1986) held at the University of Benin, Benin City, Nigeria.*
- Athol, P. (1965). Interdependence of certain operational characteristics within a moving traffic stream. *Highway Research Record 72: 58-87.*
- Aworemi, J. R., Abdul-Azeez, I. A., Oyedokun, A. J. and Adewoye, J. O. 2009. A study of the causes, effects and ameliorative measures of road traffic congestion in Lagos Metropolis. *European Journal of Social Science 11.1: 119-128.*
- Ayeni, B. 2002. An application of GIS to the analysis of maternal and child healthcare delivery in Ibadan, Nigeria.
- Bagchi, A. and Maarseveen, M. 1980. Modelling and estimation of traffic flow- a martingale approach. *International Journal of Systems Science 11.4: page.*
- Bandyopadhyay, S. N. 2001. A computer simulation model for traffic flow. *Journal of the Institution of Engineers 82: 119-124.*
- Banks, J. H. 2003. Average time gaps in congested freeway flow. *Transportation Research Part A 37.6: 539-554.*
- Barcellos, C., Feitosa, P., Damacena, G. N. and Andreazzi, M. A. 2010. Highways and outposts: economic development and health threats in the central Brazilian Amazon region. *International Journal of Health Geographics 9: 1-30*
- Brockfield, E., Kuhne R. D. and Wagner P. 2004. Calibration and validation of microscopic flow models. *Transportation Research Record 1876: 62-70.*
- Brown, J. K. M. 2010. *Experimental Design Generator and Randomiser (EDGAR).* Retrieved on 15 December 2010 from www.edgarweb.org.uk/2FactorRCB.xls.
- Byrne, A., de Laski, A., Courage, K. And Wallace, C. 1982. *Handbook of computer models for traffic operations analysis.* Technology Sharing Report FHWA-82-213, Washington, D.C.
- Chakroborty, P. 2006. Models of vehicular traffic: an engineering perspective. *Physica A: Statistical Mechanics and its Applications 372.1: 151-161.*
- Chandler, R. E., Herman R. and Montroll E. W. 1958. Traffic dynamics: studies in car following. *Operations Research 6: 165-183.*
- Chang, M. and Kim, Y. 2000. Development of capacity estimation method from statistical distribution of observed traffic flow. *Transportation Research Board: 299-309.*

- Chen, X., Li, L. and Zhang, Y. 2010. A markov model for headway/spacing distribution of road traffic. *Intelligent Transportation Systems, IEEE Transactions* 99: 1-13.
- Colombo, R. M. 2002. Hyperbolic phase transitions in traffic flow. *Society for Industrial and Applied Mathematics* 63.2: 708-721.
- Cowan, R. J. 1975. Useful headway models. *Transportation Research* 9.6: 371-375.
- Cremer, M. 1979. *Der Verkehrsfluss auf Schnellstrassen. Modelle, Überwachung, Regelung*. Fachberichte Messen, Steuern, Regeln. Berlin: Springer-Verlag.
- Cremer, M. and Papageorgiou, M. 1981. Parameter identification for a traffic flow model. *Automatica* 17: 837-843.
- Daisuke S., Izumi O. and Fumihiko, N. 1999. On estimation of vehicular time headway distribution parameters. *Traffic Engineering* 34.6: 18-27.
- Dawson, R. F. And chimini, L. A. 1968. The hyperlang probability distribution – a generalised traffic headway model. *Highway Research Record* 230: 1-14.
- Dey, P. P., Chandra, S. and Gangopadhyay, S. 2008. Simulation of mixed traffic flow on two-lane roads. *Journal of Transportation Engineering* 134.9: 361-369.
- Drew, D. R. 1968. *Traffic Flow Theory and Control*. New York: McGraw-Hill.
- Duan, Z., Liu, L. and Sun, W. 2009. Traffic congestion analysis based on Shanghai road network based on floating car data. *Proceedings of the Second International Conference on Transportation Engineering: 2731-2736*.
- Edie, L. C. and Foote, R. S. 1958. Traffic flow in tunnels. *Proceedings of Highway Research Board* 37: 334-344.
- Eisner, H. 1988. *Computer-Aided Systems Engineering*. New ersey: Prentice-Hall.
- estimates and implications”, Victoria Transport Policy Institute.
- Federal Highway Administration (FHWA). *Appendix A: Traffic Microsimulation Fundamentals*. Retrieved on 22 January 2010, from http://ops.fhwa.dot.gov/trafficanalysisistools/tat_vol3/sectapp_a.htm.
- Garner J. B. and Uren J. 1973. The use of photographic methods for traffic data collection. *The Photogrammetric Record* 7.41: 555-567.
- Gartner, N. H. Messer, C. J and Rathi, A. R. (Eds.). 1997. Introduction: *Monograph on Traffic Flow Theory*: 309-330. Retrieved 15 February 2008, from <http://www.tfhrc.gov/its/tft/tft.htm>.

- Gibson, D. and Ross, P. 1977. Simulation of traffic in streets networks. *Public Roads* 41.2: 80-90.
- GEOATLAS. 2011. Retrieved on 30 January 2011, from <http://www.business-travel-nigeria.com/map-of-nigeria.html>.
- Greenberg, H. 1959. An analysis of traffic flow. *Operations Research* 7.1:79-85.
- Greenshields, B. D. 1935. A study of traffic capacity. *Proceedings of Highway Research Board* 14: 448-474.
- Griffiths, J. D. and Hunt, J. G. 1991. Vehicle headway in urban areas. *Traffic Engineering and Control* 458-462.
- Haefner, L. E. and Li, M. S. 1998. Traffic flow simulation for an urban freeway corridor. *Transportation Research Conference Proceedings*. Retrieved on 10 January, 2007 from <http://www.ctre.iastate.edu/edu/pubs/crossroads/1traffic.pdf>.
- Hagring, O. 1996. The use of Cowan m3 distribution for modelling roundabout flow. *Traffic Engineering and Control* 37.5: 328-332.
- Hagring, O. 2000. Calibration of headway distributions. *Proceedings of the 9th Mini-Euro Conference on Handling Uncertainty in the Analysis of Traffic and Transportation Systems* http://www.iasi.cnr.it/ewgt/13conference/59_hagring.pdf retrieved on 4 March, 2008.323-328.
- Haight F. A., Whisler B. F. And Mosher W. W. 1961. New statistical method for describing highway distribution of cars. *Proceedings of Highway Research Board* 40: 557-564.
- Hall F. L. 1997. Traffic stream characteristics. In N. H. Gartner, C. J. Messer, & A. R. Rathi (Eds.). *Monograph on Traffic Flow Theory*: 309-330. Retrieved 15 February 2008, from <http://www.tfrc.gov/its/tft/tft.htm>.
- Helbing D. 2001. Traffic and related self-driven many particle systems. *Rev. Model Physics* 73: 1067-1141.
- Helbing, D. and Treiber, M. 1999. Numerical simulation of macroscopic traffic equations. *Computing in Science and Engineering* 1.5: 89-99.
- Hermann, K. 2006. A new way to organize parking: the key to a successful sustainable transport system for future. *Environment and Urbanisation* 18: 387 - 400.

- Homburger, K., Kell P., and Perkin, J. 1992. *Fundamentals of traffic engineering*. Institute of Transportation Studies, UBC.
- Hoogendoorn, S. P. and Bovy, P. H. L. 1998. A new estimation technique for vehicle-type-specific headway distributions. *Journal of the Transportation Research Board* 1646: 18-28.
- Hoogendoorn, S. P. and Bovy, P. H. L. 2001. State-of-the-art of vehicular traffic flow modelling. *Special Issue on Road Traffic Modelling and Control of the Journal of Systems and Control Engineering*: 1-46.
- Hook, W. 1995. *Urban congestion: the motorisation crisis in the world transport*. London: Sterling publishers.
- Hossain M. and Igbal G. A. 1999. Vehicular headway distribution and free speed characteristics on two-lane two way highways of Bangladesh. *Journal of the Institution of Engineers (India)* 80.2: 77-80.
- Hwang, Z., Kim, J. and Rhee, S. 2005. Development of a new highway capacity estimation method. *Proceedings of the Eastern Asia Society for Transportation Studies* 5:984-995.
- Ikya, S. G. 1993. *Urban Passenger Transportation in Nigeria*. Ibadan: Heinemann.
- Jia, M. 2009. Simulation for dynamic traffic flow. <http://www.infra.kth.se/tla/tlenet/meet5/papers/Jia.pdf> (retrieved on 22 February, 2009)
- Johnson, R. A. 2001. Miller and Freund's *Probability and statistics for engineers*. New Delhi: Prentice-Hall of India.
- Junevicius, R. and Bogdevicius, M. 2009. Mathematical modelling of network traffic flow. *Transport* 24.4: 333-338.
- Kadiyali, L. R. 2007. *Traffic Engineering and Transportation Planning*. Delhi: Khanna
- Kallberg, H. 1971. Traffic simulation (in Finnish). Licentiate thesis. Helsinki, University of Technology.
- Kerner, B. S. 2004. *The Physics of Traffic* Berlin: Springer.
- Kerner, B. S., Rehborn, H., Aleksic, M. and Haug, A. 2001. Methods for tracing and forecasting of congested traffic patterns on highways. *Traffic Engineering and Control* 42: 282-287.

- Khasnabis, S. and Heimbach, C. L. 1980. Headway-distribution models for two-lane rural highways. *Transportation Research Record: Traffic flow theory, characteristics, and capacity* 772:44-51.
- Khisty, C. J. and Lall, B. K. 2006. *Transportation Engineering – An Introduction*. New Delhi: Prentice Hall.
- Kinzer, J. P. 1933. Application of the theory of probability to problems of highway traffic. Unpublished Thesis, Polytechnic Institute of Brooklyn* *check*
- Kolowksy M. and Moshe K. 1993. On the relationship between commuting, stress, symptoms, and altitudinal measures. *Journal of Applied Behavioural Science* 485 – 492.
- Kosonen, H. 1999. HUTSIM – Urban traffic simulation and control model: principles and applications. *Transportation Engineering Publication 100* Espoo: Helsinki University of Technology.
- Kubel, L., Bloodgood G., Workmon F. and Gibson D.1978. What network simulation (NETSIM) can do for the traffic engineer. *Public Roads* 41.4: 62-168.
- Kyte, M. and Tepley, S. 1999. Traffic and flow characteristics. *Traffic Engineering Handbook*, 5th ed. (J. L. Pline, ed.). Institute of Transportation Engineers.
- Lee, W. P., Osman M. A., Talib A. Z. and Md.Ismail A. I. 2008. Dynamic traffic simulation for traffic congestion problem using an enhanced algorithm. *World Academy of Science, Engineering and Technology* 45: 271-278.
- Lenth, R. V. (2006-9). Java Applets for Power and Sample Size [Computer software]. Retrieved 14 December, 2010, from <http://www.stat.uiowa.edu/~rlenth/Power>.
- Leuzbach, W. 1988. *Introduction to the theory of traffic flow*. Heidelberg: Springer-Verlag.
- Lieberman. E. and Rathi, A.K. 1997. Traffic simulation. In N. H. Gartner, C. J. Messer, & A. R. Rathi (Eds.). *Monograph on Traffic Flow Theory*: 309-330. Retrieved 15February 2008, from <http://www.tfhrc.gov/its/tft/tft.htm>.
- Lighthill, M. J. and Whitham, G. B. 1955. On Kinematic Waves: II. A theory of traffic flow on long crowded roads. *Proceedings of the Royal Society A*229: 317- 347.
- Litman, T. 2005. “Congestion costs, transportation cost and benefit analysis, techniques,

- Lu, J. 1990. Prediction of traffic flow by an adaptive prediction system. *Transportation Research Record* 1287: 54-61
- Luttinen, R. T. 2004. Capacity and level of service at finnish unsignalised intersections. *Finnra Reports* (1/2004) Helsinki: Finnish Road Administration.
- Maerivoet S. and De Moor B. 2005. Traffic Flow Theory. *Technical Reports* ESAT-SCD (SISTA) / TR 05-154
- Mallikarjuna, C. and Rao, K. R. 2010. Heterogeneous traffic flow modelling: a complete methodology. *Transportmetrica* page..
- Mannering, F. L. and Kilareski, W. P. 1997. *Principles of Highway Engineering and Traffic Analysis* New Jersey: Wiley.
- May, A. D. 2001. Introduction to traffic flow theory. In C. A. O'Flaherty (Ed.). *Transport Planning and Traffic Engineering*. Bristol: Butterworth-Heinemann.
- May, A. D., Athol, P., Parker, W., and Rudden, J. B. 1963. Development and evaluation of congress street expressway pilot detection system. *Highway Research Record* 21: 48-70.
- Metcalf, A.V. 1997. *Statistics in civil engineering*. London: Arnold.
- Meyer , B. 1985. [On formalism in specifications](#). *IEEE Software*: 2: 6-26.
- Nagatani T. 2002. The physics of traffic jams. *Reports on Progress in Physics* 65: 1331-1386.
- Neelamkavil, F. 1987. *Computer Simulation and Modelling*. New York: John Wiley & Sons.
- Newell, G. F. (1955). Mathematical models for freely flowing highway traffic. *Operations Research* 3: 176-186.
- O'Flaherty, C. A. 2001. Road capacity and design-standard approaches to road design. In C. A. O'Flaherty (Ed.). *Transport Planning and Traffic Engineering*. Bristol: Butterworth-Heinemann.
- Ogilvie, D., Matt, E., Val, H., and Mark, P. 2004. Promoting walking and cycling as an alternative to using cars: systematic review. *British Medical Journal* 329.7469: 763.
- Oglesby, C. H. and Hicks, R. G. 1982. *Highway Engineering*. New York: John Wiley & Sons.
- Oguara, T. M. 2006. *Highway engineering: geometric design*. Lagos: Malthouse.

- Oluwoye, J. 2009. An empirical analysis of socio-economic impacts on traffic generation in metropolitan areas. *The International Journal of Technology, Knowledge and Society* 5.1:115-126
- Osula, D. O. A. 2010. *Transportation planning as a prerequisite for road infrastructural development*. Presented at the 3rd Lawrence Arokodare day lecture (27 April, 2010), Jogor Centre, Ibadan.
- Owolabi, A.O. and Adebisi, O. 1993. Mathematical models for headways in traffic streams. *NSE Technical Transactions* 31.4: 48-57.
- Owolabi, A.O. and Adebisi, O. 1996. Application of headway models. *NSE Technical Transactions* 28.4: 1-10.
- Oyawale, F. A. 2005. *Statistical methods: an introduction*. Ibadan: International Publishers.
- Payne, H. J. 1979. FREFLO: A macroscopic simulation model of freeway traffic. *Transportation Research Record* 722: 68-77.
- Pipes, L. A. 1953. An operational analysis of traffic dynamics. *Journal of Applied Physics* 24.3: 274-281.
- Polus, A. and Cohen, M. 2009. Theoretical and empirical relationships for the quality of flow and for a new level of service on two-lane highways. *Journal of Transportation Engineering* 135.6: 380-385.
- Pongpaibool, P., Tangamchit, P. and Noodwong, K. 2007. Evaluation of road traffic congestion using fuzzy techniques. *Proceeding of IEEE TENCON 2007*, Taipei, Taiwan.
- Posawang, P., Phosaard S., Pattara-Atikom, W. and Polnigongit, W. 2009. Perception-based Road Traffic Congestion Classification using Neural Networks. *Proceedings of the World Congress on Engineering, Vol. 1* (July 1 – 3, 2009), London, U.K.
- Pursula, M. 1999. Simulation of traffic systems - an overview. *Journal of Geographic Information and Decision Analysis* 3.1: 1-8.
- Putcha, C. S., Kreiner, J. H., Tadi, R. R. and [Charoensuphong](#), M. 2006. Development of a new traffic flow model. *Proceedings of the 17th IASTED international conference on Modelling and simulation*: 134-136.
- Radilat, G. and Tiller, G. 1981. A new system for traffic simulation. *Public Roads* 45.1: 19-26.

- Salter, R. J. 1990. *Highway traffic analysis and design*. Hampshire: ELBS/Macmillan.
- Salter, R. J. and Hounsell, N. B. 1996. *Highway Traffic Analysis and Design*, Macmillan: London.
- Sanjay, K. S. 2005. Review of Urban transportation in India, *Journal of Public Transport* 8.1:
- Singh, G. and Singh, J. 2006. *Highway Engineering*. Delhi: Standard.
- Sullivan, D. P. And Troutbeck, R. J. 1994. The use of Cowan M3 headway distribution for modelling urban traffic flow. *Traffic Engineering and Control* 35: 600- 603.
- Tanyel, S., Baran, T. and Ozuysal, M. 2005. Determining the capacity of single-lane roundabouts in Izmir, Turkey. *Journal of Transportation Engineering* 131.12: 953-956.
- Tele Atlas Africa. 2007. Nigeria Streetmaps (Topographical and Recreation). *PTY Limited*: Licence 1418-1.
- Texas Transportation Institute. 2009. Components of the congestion problem. 2005 urban areas totals. Retrieved on 10/06/2009.
- Tolle, J. E. 1971. The lognormal headway distribution model. *Traffic Engineering and Control* 13.1: 22-24.
- Transportation Research Board (TRB) 2000. *Highway Capacity Manual*. Washington D.C.: National Research Council. HCM2000, metric units.
- Treiber, M., Hennecke, A. and Helbing, D. 2000. Congested traffic states in empirical observations and microscopic simulations. *Physical Review E* 62: 1805-1824.
- Tugbobo, B. 2009. The traffic congestion problem in developing countries: study of Lagos State, Nigeria: causes, consequences, costs, and what can be done. *Transportation Research Forum*. www.trforum.org/forum/proceedings.php?year=2009 (retrieved on 21 February 2010).
- U.S. Federal Highway Administration. 2005. *Traffic Congestion and Reliability-Trends and Advanced Strategies for Congestion Mitigation*.
- Wang, H. F. and [Anderson, M. P.](#) 1982. *Introduction to groundwater modelling: Finite difference and finite element methods*. Freeman and Company.

- Wardrop J.G. 1952. Some theoretical aspects of road traffic research. In *Proceedings of the Institution of Civil Engineers Part II*, 1.2: 325-362.
- Webster, F. V. 1957. *Traffic Signal Settings*. Road Research Technical Paper No. 39. London: Road Research Laboratory.
- Wikipedia. 2010. <http://en.wikipedia.org/wiki/Highway> (retrieved on 30 September 2010).
- Wilson. A. 1968. *The Bomb and the Computer*. New York: Delacorte Press.
- Wright, P. W. 1996. *Highway Engineering*. New York: Wiley.
- Wright, P. W. and Dixon, K. K. 2004. *Highway Engineering*. New Jersey: Wiley.
- Wu, N. 2002. A new approach for modelling of fundamental diagrams. *Transportation Research Part A* 36: 867-884.
- Yao, J., Rakha, H., Teng, H., Kwigizile, V. and Kaseko M. 2009. Estimating highway capacity considering two-regime models. *Journal of Transportation Engineering* 135.9: 670-676.
- Yi, P., Zhang Y., Lu, J. and Lu, H. 2004. Safety-based capacity analysis for Chinese highways – a preliminary study. *IATSS RESEARCH* 28.1: 47-55.
- Yin, S., Li, Z. Zhang, Y., Yao, D., Su, Y. and Li, L. 2009. Headway distribution modelling with regard to traffic status. *Intelligent Vehicles Symposium, 2009 IEEE*: 1057 – 1062.
- Li, Z., Yin, S., Tian, Y., Li, L., Zhao, Z. and Ji, Y. 2008. Urban traffic flow volume modelling for Beijing using a mixed-flow model.
- Yuichi, K. and Shizuma Y. 1989. A practical method for estimating the headway distribution based on the observed data of the number of flowing vehicles: Gamma distribution model. *Journal of the Acoustical Society of Japan* 10.6: 357-361.
- Zang, X. 2010. Modelling and simulation for theoretic capacity model of highway. *Computer Modelling and Simulation* 1: 261-263.
- Zhang, G., Wang, Y., Wei, H. And Chen, Y. 2007. Examining headway distribution models with urban freeway loop event data. *Transportation Research Record* 1999: 141-149.
- Zwahlen, H. T., Oner, E. and Suravaram, K. R. 2007. Approximated headway distributions of free-flowing traffic on Ohio freeways for work-zone traffic simulations. *Transportation Research Record* 1999: 131-140.

APPENDICES

Appendix A1: SONY Camcorder Operating Guide

HDR-HC3

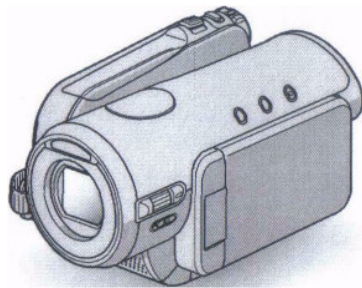

Additional information on this product can be found at
<http://www.sony.net>

Recording/Playback

Recording

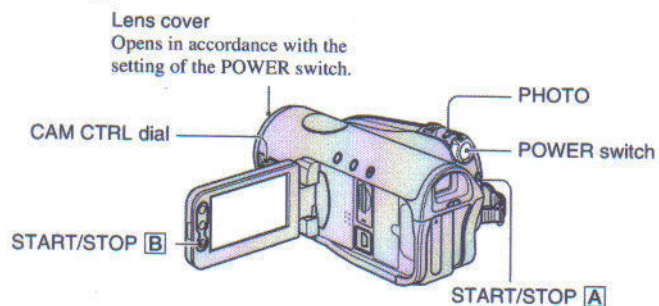

1 Slide the POWER switch in the direction of the arrow repeatedly to turn on the respective lamp to select a recording medium.

Movies on tape: The CAMERA-TAPE lamp lights up.

Still images on "Memory Stick Duo": The CAMERA-MEMORY lamp lights up.*

* The image size ratio is set by default to 4:3.

If the POWER switch is set to OFF (CHG), slide it while pressing the green button.

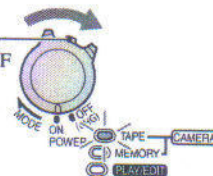

2 Start recording.

Movies

Press START/STOP **A** (or **B**).

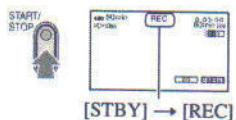

To stop the movie recording, press START/STOP again.

• The pictures are recorded in the HDV format in the default setting

Still images

Press and hold PHOTO lightly to adjust the focus (**A**), then press it fully (**B**).



A shutter sound is heard. When disappears, the image has been recorded.

Playback

- Slide the POWER switch in the direction of the arrow repeatedly to turn on the PLAY/EDIT lamp.

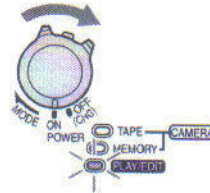

- Start playing back.

Movies

Touch to rewind the tape to the desired point, then touch to start playback.

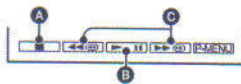

- A Stop
- B Play/Pause toggles as you touch it
 - Playback automatically stops if pause is engaged for more than 3 minutes.
- C Rewind/Fast forward
 - MEMORY is not displayed when a "Memory Stick Duo" is not inserted or no image files exist in it.

Still images

Touch MEMORY. The most recently recorded image is displayed.

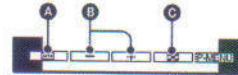

- A Tape playback
- B Previous/Next
- C Index screen display
 - When a "Memory Stick Duo" is inserted, MEMORY appears by touching .

Recording/Playback

To adjust the volume

Rotate the CAM CTRL dial to adjust the volume.

- You can also adjust the volume on the menu.

To search for a scene during playback

Touch and hold / during playback (Picture Search), or / while fast forwarding or rewinding the tape (Skip Scan).

- You can play back in various modes (VAR, SPD PB).

To display pictures on a "Memory Stick Duo" on the Index screen

Touch . Touch one of the pictures to back to the single display mode.

To view pictures in other folders, touch → [SET] → [PB FOLDER], select a folder with /, then touch [OK].

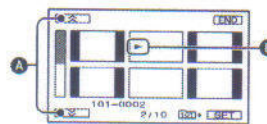

- A Previous/Next 6 pictures
- B The picture displayed before switching to the index screen.

Functions used for recording/playback, etc.

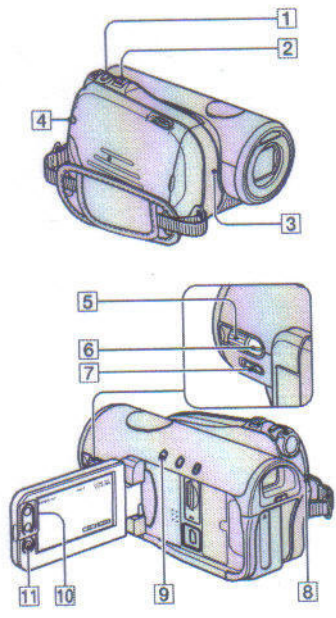

Recording

To use zoom 2 10

Move the power zoom lever 2 slightly for a slower zoom. Move it further for a faster zoom.

Wider range of view: (Wide angle)

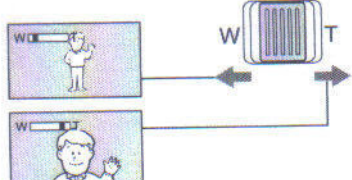

Close view: (Telephoto)

- You cannot change the zoom speed with the zoom buttons 10 on the LCD panel.
- The minimum possible distance between camcorder and subject while maintaining sharp

focus is about 1 cm (about 13/32 in.) for wide angle and about 80 cm (about 2 5/8 feet) for telephoto.

- You can set [DIGITAL ZOOM] (p. 57) if you want to zoom to a level greater than 10 x.
- Be sure to keep your finger on the power zoom lever. If you move your finger off the power zoom lever, the operation sound of the power zoom lever may also be recorded.

To record high quality still images during tape recording (Dual Rec)

..... 1 8 11

You can record high quality still images on the "Memory Stick Duo" during tape recording.

- 1 Press START/STOP 8, 11 to start tape recording.
- 2 Press PHOTO 1 fully.
For each separate time tape recording, up to 3 still images can be recorded.

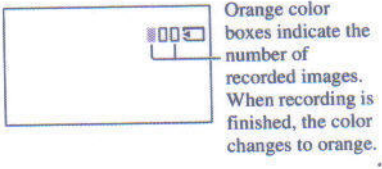

- 3 Press START/STOP 8, 11 to stop tape recording.

Stored still images appear one by one, and the images are stored onto the "Memory Stick Duo." When [||||] disappears, the image has been recorded.

- When the POWER switch is set to CAMERA-TAPE, still images will be recorded at image size 2.3M in the HDV format, 1.7M (4:3) or 2.3M (16:9) in the DV format.
- Do not eject the "Memory Stick Duo" before tape recording is finished and the still images are stored on the "Memory Stick Duo."
- You cannot use the flash during Dual Rec.
- During the standby mode, still images will be stored in the same way as when the POWER switch is set to CAMERA-MEMORY. You can use the flash.

To control the image settings manually with the dial (CAM CTRL dial/MANUAL button) [5] [6]

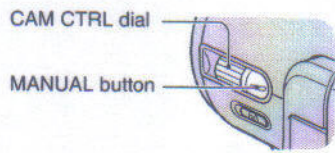

You can assign some of the camera settings to the CAM CTRL dial [5] such as focus adjustment (default setting) for details.

During playback, you can adjust the volume using the CAM CTRL dial [5] (p. 31).

- At the time of purchase, the [FOCUS] (p. 54) setting is assigned to the CAM CTRL dial [5]. If you press the MANUAL button [6], you can switch from the auto setting to the manual setting and adjust the focus manually.

To use the flash [4]

Press ⏏ (flash) [4] repeatedly to select an appropriate setting.

No indication (Auto flash): Automatically flashes when there is insufficient ambient light.



⏏ (Forced flash): Always uses the flash regardless of the surrounding brightness.



⏏ (No flash): Records without flash.

- The recommended distance to the subject when using the built-in flash is 0.5 to 2.5 m (1 5/8 to 8 feet).
- Remove any dust from the surface of the flash lamp before using it. Flash effect may be impaired if heat discoloration or dust obscures the lamp.
- The flash charge lamp flickers when charging the flash, and remains lit when the battery charge is complete. (In [STBY] of the CAMERA-TAPE mode, it takes a while to fully charge the flash lamp.)
- You cannot use the flash during tape recording.

- If you use the flash in bright places such as when shooting a backlit subject, the flash may not be effective.
- When attaching a conversion lens (optional) or a filter (optional) to your camcorder, the flash light does not emit light.
- You can change the brightness of the flash by setting [FLASH LEVEL], or you can prevent the redeye by setting [REDEYE REDUC], in [FLASH SET].

To record in dark places (NightShot) [7]

Set the NIGHTSHOT switch [7] to ON. (☑ and ["NIGHTSHOT"] appear.)

- To record an image brighter, use Super NightShot function (p. 55). To record an image more faithful to the original colors, use Color Slow Shutter function (p. 56).
- The NightShot and Super NightShot function use infrared light. Therefore, do not cover the infrared port [3] with your fingers or other objects and remove the conversion lens (optional).
- Adjust the focus manually ([FOCUS], p. 54) when it is hard to focus automatically.
- Do not use these functions in bright places. This may cause a malfunction.

To adjust the exposure for backlit subjects [9]

To adjust the exposure for backlit subjects, press BACK LIGHT [9] to display ⏏ . To cancel the back light function, press BACK LIGHT again.

- The setting you have made will return to the default setting if you set the POWER switch to OFF (CHG) for more than 12 hours.

Functions used for recording/playback, etc. (Continued)

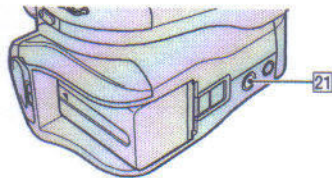
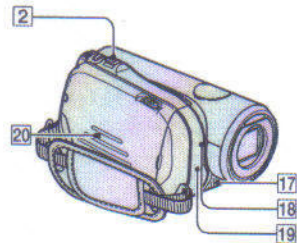
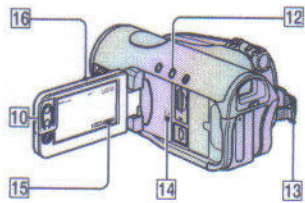

To record in mirror mode 16

Open the LCD panel 16 90 degrees to the camcorder (1), then rotate it 180 degrees to the lens side (2).

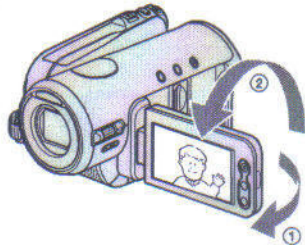

• A mirror-image of the subject appears on the LCD screen, but the picture will be normal when recorded.

To use a tripod 21

Attach the tripod (optional: the length of the screw must be less than 5.5 mm (7/32 in.)) to the tripod receptacle 21 using a tripod screw.

To use a Shoulder belt 13

Attach the Shoulder belt (optional) to its designated hook 13.

Playback

To use PB zoom 2 10

You can magnify images from about 1.1 to 5 times (from about 1.5 to 5 times in still images) the original size.

Magnification can be adjusted with the power zoom lever 2 or the zoom buttons 10 on the LCD panel.

- ① Play back the picture you want to magnify.
- ② Magnify the picture with T (Telephoto).
- ③ Touch the screen at the point you want to display in the center of the displayed frame.
- ④ Adjust the magnification with W (Wide angle)/T (Telephoto).

To cancel, touch [END].

• You cannot change the zoom speed with the zoom buttons 10 on the LCD panel.

Recording/playback

To check the remaining battery (Battery Info)..... 12

Set the POWER switch to OFF (CHG), then press DISP/BATT INFO 12. The approximate recordable time in the selected format and battery information appear for about 7 seconds. You can view the battery information for up to 20 seconds by

pressing DISP/BATT INFO again while the information is displayed.

Remaining battery (approx.)

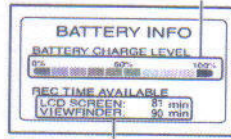

Recording capacity (approx.)

To turn off the operation confirmation beep (BEEP) 15

See [BEEP]

To initialize the settings (RESET) 20

Press RESET **20** to initialize all the settings, including the setting of the date and time.

(Menu items customized on Personal Menu are not initialized.)

Other part names and functions

- 14** Speaker
Playback sounds come out from the speaker.
 - For how to adjust the volume
- 17** Internal stereo microphone
An Active Interface Shoe compatible microphone (optional) will take precedence when connected.
- 18** REC lamp
The REC lamp lights up in red during recording.
The REC lamp flashes if the remaining tape or battery power is low.
- 19** Remote sensor
Point the Remote Commander () towards the remote sensor to operate your camcorder.

Indicators displayed during recording/playback

Recording movies

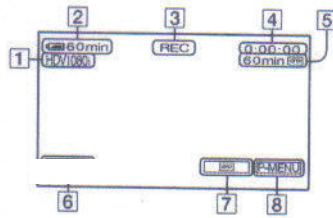

- 1 Recording format (HDV1080i or DV) (66)
Recording mode (SP or LP) is also displayed in the DV format.
- 2 Remaining battery (approx.)
- 3 Recording status ([STBY] (standby) or [REC] (recording))
- 4 During recording:
Tape counter (hour: minute: second)
During playback:
Time code (hour: minute: second: frame)
- 5 Recording capacity of the tape (approx.) (69)
- 6 Review button for still images on the "Memory Stick Duo" (32)
Appears when "Memory Stick Duo" is inserted.
- 7 ENL/PERSONAL/Rec review display switch button (39)
- 8 Personal Menu button (48)

Recording still images and recording (Dual Rec)

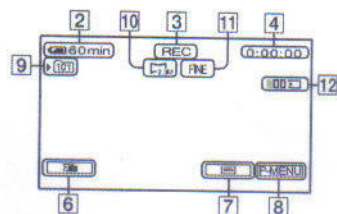

- 9 Recording folder (60)
- 10 Image size (58)
- 11 Quality ([FINE] or [STD]) (58)
- 12 Number of recorded still images (32)

Recording still images

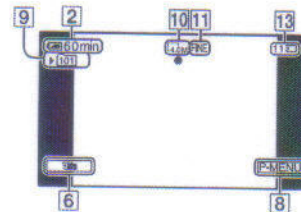

- 13 "Memory Stick Duo" indicator and the number of images that can be recorded (approx.)

Data code during recording

The date/time during recording and the camera setting data will be recorded automatically. They do not appear on the screen during recording, but you can check them as [DATA CODE] during playback.

Appendix A2: Extracted field headway data at different flow regimes

Headway (s) 740vph	Headway (s) 776vph	Headway (s) 812vph	Headway (s) 852vph	Headway (s) 900vph	Headway (s) 988vph	Headway(s) 1108vph
0.35	0.40	0.37	0.36	0.35	0.31	0.34
0.36	0.43	0.49	0.39	0.39	0.31	0.36
0.39	0.47	0.52	0.44	0.42	0.35	0.38
0.45	0.51	0.53	0.44	0.53	0.36	0.38
0.46	0.53	0.55	0.49	0.56	0.38	0.38
0.50	0.54	0.58	0.52	0.64	0.39	0.40
0.52	0.62	0.60	0.55	0.70	0.41	0.44
0.57	0.64	0.63	0.56	0.70	0.50	0.45
0.57	0.66	0.67	0.57	0.70	0.56	0.46
0.63	0.72	0.76	0.66	0.71	0.58	0.49
0.65	0.75	0.76	0.68	0.77	0.66	0.50
0.72	0.75	0.87	0.69	0.79	0.66	0.56
0.77	0.82	0.91	0.69	0.80	0.68	0.57
0.80	0.84	0.93	0.70	0.82	0.69	0.58
0.83	0.87	0.94	0.71	0.82	0.71	0.59
0.86	0.92	0.97	0.75	0.90	0.72	0.60
0.86	0.94	0.97	0.75	0.94	0.73	0.63
0.87	0.97	0.99	0.76	0.97	0.76	0.64
0.87	0.98	1.00	0.77	0.99	0.76	0.73
0.87	0.98	1.01	0.80	0.99	0.78	0.77
0.94	0.99	1.03	0.80	1.00	0.80	0.78
0.98	0.99	1.05	0.81	1.04	0.81	0.78
1.01	0.99	1.08	0.81	1.13	0.82	0.79
1.01	1.06	1.08	0.89	1.15	0.86	0.79
1.04	1.06	1.10	0.89	1.15	0.88	0.79
1.07	1.08	1.12	0.95	1.16	0.89	0.80
1.14	1.13	1.13	0.96	1.16	0.89	0.81
1.17	1.17	1.14	0.98	1.19	0.90	0.82
1.18	1.17	1.17	0.98	1.20	0.91	0.82
1.20	1.22	1.17	1.03	1.21	0.93	0.85
1.20	1.25	1.17	1.07	1.24	0.95	0.86
1.21	1.26	1.18	1.08	1.25	0.96	0.86
1.21	1.27	1.19	1.09	1.26	0.96	0.86
1.21	1.28	1.19	1.09	1.26	0.97	0.87
1.23	1.29	1.20	1.16	1.26	0.97	0.88
1.24	1.30	1.21	1.17	1.26	0.98	0.92
1.24	1.32	1.24	1.18	1.26	0.98	0.92
1.24	1.35	1.27	1.18	1.29	1.00	0.92
1.25	1.35	1.28	1.19	1.33	1.03	0.93
1.26	1.36	1.29	1.20	1.34	1.03	0.94
1.27	1.36	1.30	1.20	1.35	1.04	0.95
1.27	1.38	1.34	1.20	1.35	1.06	0.96

740vph	776vph	812vph	852vph	900vph	988vph	1108vph
1.28	1.40	1.36	1.20	1.35	1.07	0.97
1.28	1.42	1.38	1.22	1.38	1.08	0.97
1.33	1.42	1.38	1.22	1.38	1.09	0.99
1.35	1.42	1.41	1.28	1.40	1.09	1.04
1.35	1.44	1.41	1.29	1.43	1.09	1.04
1.35	1.44	1.43	1.30	1.44	1.10	1.04
1.39	1.45	1.43	1.30	1.45	1.14	1.05
1.43	1.49	1.45	1.30	1.46	1.16	1.06
1.47	1.49	1.47	1.34	1.51	1.17	1.07
1.50	1.58	1.48	1.36	1.55	1.17	1.10
1.51	1.58	1.48	1.37	1.56	1.17	1.10
1.51	1.63	1.48	1.38	1.56	1.19	1.11
1.51	1.64	1.49	1.41	1.56	1.23	1.11
1.52	1.65	1.49	1.43	1.56	1.24	1.12
1.53	1.71	1.52	1.44	1.58	1.24	1.12
1.54	1.72	1.52	1.44	1.60	1.27	1.12
1.57	1.77	1.59	1.45	1.61	1.27	1.12
1.58	1.77	1.60	1.46	1.66	1.27	1.13
1.63	1.78	1.61	1.50	1.67	1.28	1.13
1.64	1.83	1.61	1.50	1.69	1.29	1.15
1.66	1.83	1.61	1.51	1.72	1.29	1.16
1.67	1.88	1.62	1.53	1.73	1.29	1.16
1.67	1.99	1.66	1.56	1.74	1.30	1.18
1.68	2.05	1.66	1.60	1.75	1.33	1.19
1.73	2.06	1.70	1.62	1.76	1.33	1.19
1.75	2.07	1.78	1.62	1.79	1.35	1.19
1.75	2.12	1.83	1.62	1.80	1.37	1.20
1.78	2.18	1.85	1.63	1.81	1.38	1.20
1.80	2.21	1.85	1.64	1.84	1.38	1.22
1.81	2.23	1.85	1.64	1.86	1.40	1.22
1.81	2.24	1.86	1.66	1.86	1.41	1.23
1.90	2.27	1.87	1.66	1.91	1.41	1.23
1.92	2.28	1.87	1.67	1.92	1.43	1.23
1.93	2.33	1.87	1.68	1.92	1.44	1.24
1.96	2.39	1.93	1.70	1.94	1.46	1.24
1.96	2.43	1.94	1.70	1.96	1.46	1.24
2.03	2.45	1.97	1.75	1.97	1.47	1.26
2.03	2.46	1.97	1.78	1.99	1.52	1.26
2.04	2.46	1.98	1.79	2.00	1.52	1.27
2.12	2.48	2.00	1.80	2.01	1.54	1.28
2.13	2.52	2.01	1.81	2.03	1.55	1.30
2.17	2.52	2.05	1.85	2.04	1.57	1.30
2.18	2.53	2.06	1.87	2.04	1.59	1.30
2.20	2.56	2.06	1.87	2.05	1.59	1.30
2.22	2.63	2.13	1.90	2.06	1.65	1.30

740vph	776vph	812vph	852vph	900vph	988vph	1108vph
2.27	2.65	2.14	1.92	2.06	1.66	1.30
2.32	2.66	2.16	1.95	2.06	1.67	1.31
2.34	2.67	2.18	1.97	2.08	1.67	1.32
2.36	2.67	2.21	1.98	2.10	1.68	1.34
2.36	2.86	2.22	2.07	2.12	1.69	1.34
2.38	2.97	2.24	2.14	2.15	1.69	1.36
2.42	2.97	2.25	2.15	2.16	1.71	1.37
2.42	2.98	2.26	2.16	2.16	1.73	1.38
2.43	3.03	2.26	2.20	2.16	1.74	1.38
2.50	3.03	2.29	2.23	2.16	1.77	1.41
2.57	3.11	2.39	2.24	2.25	1.80	1.43
2.65	3.12	2.40	2.24	2.25	1.82	1.43
2.67	3.12	2.55	2.25	2.28	1.83	1.44
2.72	3.29	2.65	2.26	2.29	1.84	1.45
2.77	3.32	2.66	2.31	2.30	1.84	1.46
2.77	3.38	2.72	2.42	2.33	1.84	1.48
2.83	3.40	2.89	2.44	2.34	1.85	1.49
2.86	3.41	2.90	2.46	2.35	1.86	1.51
2.86	3.44	2.91	2.48	2.36	1.87	1.51
2.98	3.50	2.96	2.53	2.36	1.87	1.52
2.99	3.55	3.01	2.54	2.38	1.89	1.52
3.10	3.60	3.01	2.56	2.45	1.92	1.54
3.19	3.67	3.05	2.58	2.46	1.92	1.56
3.19	3.79	3.07	2.66	2.47	1.93	1.57
3.25	3.83	3.11	2.70	2.49	1.95	1.58
3.28	3.90	3.15	2.84	2.49	1.95	1.60
3.29	4.01	3.20	2.93	2.52	1.95	1.62
3.32	4.07	3.26	3.09	2.53	1.96	1.63
3.34	4.08	3.39	3.09	2.54	1.97	1.63
3.36	4.12	3.43	3.12	2.56	2.07	1.63
3.42	4.19	3.50	3.16	2.59	2.12	1.65
3.48	4.25	3.53	3.24	2.61	2.14	1.67
3.58	4.27	3.57	3.30	2.64	2.14	1.67
3.64	4.32	3.59	3.34	2.68	2.22	1.69
3.66	4.34	3.64	3.35	2.73	2.32	1.69
3.72	4.37	3.66	3.39	2.73	2.33	1.73
3.72	4.40	3.69	3.44	2.80	2.34	1.75
3.84	4.56	3.75	3.45	2.82	2.35	1.75
3.91	4.56	3.79	3.53	2.86	2.35	1.76
4.00	4.60	3.85	3.57	2.87	2.37	1.76
4.04	4.62	3.89	3.57	2.88	2.40	1.77
4.13	4.65	3.94	3.63	2.90	2.44	1.82
4.30	4.75	3.96	3.67	2.91	2.45	1.82
4.34	4.88	3.98	3.68	2.95	2.48	1.83

740vph	776vph	812vph	852vph	900vph	988vph	1108vph
4.37	4.89	4.00	3.70	2.96	2.48	1.85
4.38	4.90	4.12	3.77	2.96	2.50	1.86
4.41	5.07	4.20	3.78	2.97	2.52	1.87
4.62	5.32	4.37	3.90	3.11	2.54	1.90
4.85	5.33	4.43	3.90	3.13	2.59	1.91
5.04	5.34	4.43	3.93	3.13	2.60	1.95
5.12	5.41	4.47	3.96	3.16	2.63	1.95
5.19	5.44	4.50	3.99	3.17	2.63	1.95
5.66	5.47	4.50	4.00	3.27	2.64	1.96
5.81	5.47	4.54	4.05	3.27	2.65	1.96
6.04	5.56	4.61	4.06	3.34	2.68	1.96
6.32	5.76	4.62	4.07	3.35	2.71	1.98
6.37	5.85	4.64	4.18	3.43	2.81	2.03
6.46	5.96	4.71	4.19	3.47	2.83	2.05
6.61	6.01	4.86	4.23	3.47	2.89	2.06
6.73	6.16	4.86	4.37	3.51	2.91	2.11
6.80	6.21	4.98	4.39	3.51	2.95	2.12
6.97	6.22	5.15	4.40	3.56	2.95	2.14
7.06	6.30	5.15	4.41	3.57	3.00	2.17
7.21	6.46	5.20	4.45	3.59	3.19	2.18
7.31	6.48	5.44	4.48	3.63	3.20	2.19
7.37	6.52	5.57	4.48	3.64	3.24	2.22
7.59	6.58	5.71	4.59	3.65	3.28	2.23
7.67	6.68	5.96	4.93	3.66	3.34	2.26
8.37	6.76	5.99	4.94	3.72	3.48	2.27
8.50	6.88	6.06	4.94	3.73	3.50	2.30
8.85	7.02	6.20	4.96	3.84	3.59	2.41
9.78	7.25	6.37	4.98	3.90	3.62	2.42
9.98	7.37	6.37	5.17	3.96	3.65	2.42
10.54	7.45	6.39	5.27	3.97	3.69	2.44
10.72	7.74	6.41	5.33	4.00	3.73	2.47
10.74	8.13	6.44	5.37	4.08	3.85	2.53
11.83	8.17	6.46	5.48	4.08	3.89	2.55
12.95	8.62	6.54	5.60	4.10	3.98	2.55
13.44	9.11	6.72	5.74	4.11	4.07	2.58
15.01	9.12	6.75	5.76	4.13	4.12	2.59
15.09	9.39	6.82	5.95	4.19	4.18	2.60
15.13	9.46	6.99	5.96	4.19	4.21	2.62
15.53	9.58	7.01	5.97	4.23	4.21	2.74
17.28	9.73	7.33	6.08	4.27	4.23	2.80
17.54	10.03	7.38	6.32	4.29	4.24	2.82
18.00	10.03	7.88	6.39	4.29	4.34	2.83
18.11	10.05	8.15	6.39	4.43	4.36	2.88
19.51	10.24	8.18	6.50	4.55	4.36	2.88
19.61	10.42	8.49	6.63	4.67	4.46	2.89

740vph	776vph	812vph	852vph	900vph	988vph	1108vph
20.20	10.98	8.52	6.75	4.76	4.53	2.90
20.38	11.09	8.55	7.16	4.99	4.58	2.96
23.92	11.17	8.75	7.41	5.05	4.61	2.97
26.10	11.81	8.91	7.69	5.07	4.61	2.99
35.01	13.19	9.28	7.82	5.42	4.75	3.01
44.02	13.48	9.32	8.15	5.52	4.75	3.02
	13.74	9.39	8.44	5.58	4.75	3.03
	13.89	9.44	8.50	5.73	4.77	3.03
	14.50	9.46	8.61	5.85	4.83	3.04
	15.21	10.09	8.85	5.96	4.92	3.08
	18.99	10.17	9.35	6.10	4.95	3.13
	19.81	10.38	9.40	6.13	4.97	3.14
	20.76	10.91	9.74	6.18	5.17	3.15
	22.00	12.64	9.76	6.26	5.19	3.21
	25.35	13.00	9.79	6.30	5.21	3.29
	29.27	13.47	10.20	6.42	5.29	3.31
		13.89	10.24	6.68	5.30	3.43
		15.92	10.59	6.68	5.32	3.43
		16.83	10.71	6.70	5.36	3.44
		17.05	10.78	6.71	5.38	3.47
		18.08	11.18	6.72	5.38	3.64
		20.23	11.34	7.00	5.44	3.66
		21.22	11.90	8.28	5.69	3.72
		23.79	12.42	8.38	5.76	3.74
		28.40	12.87	8.69	5.95	3.80
		35.22	12.96	8.77	6.01	3.82
			12.98	8.90	6.02	3.83
			14.99	8.94	6.10	3.84
			15.12	9.12	6.33	3.86
			15.54	9.16	6.44	3.92
			16.17	9.27	6.50	3.98
			21.51	9.38	6.51	4.00
			21.69	9.80	6.73	4.12
			25.93	10.97	6.74	4.15
			36.17	11.15	6.75	4.19
				11.89	6.91	4.21
				12.24	7.06	4.35
				13.51	7.26	4.45
				14.83	7.45	4.54
				15.07	7.50	4.61
				16.80	7.65	4.65
				17.41	7.67	4.66
				21.61	7.72	4.67
				22.97	7.77	4.69
				24.87	7.80	4.72

740vph	776vph	812vph	852vph	900vph	988vph	1108vph
				30.42	8.16	4.75
					8.19	4.77
					8.40	4.88
					9.44	4.89
					9.57	4.91
					9.77	5.14
					9.96	5.24
					10.41	5.36
					10.47	5.44
					11.27	5.63
					11.63	5.75
					12.05	5.79
					12.20	5.88
					12.26	5.97
					12.50	6.02
					12.65	6.13
					12.98	6.20
					13.95	6.43
					14.84	6.48
					15.49	6.48
					15.72	6.63
					17.65	6.73
					29.11	7.13
						7.15
						7.22
						7.27
						7.41
						7.57
						7.71
						8.12
						8.25
						8.59
						8.86
						9.41
						9.56
						9.61
						10.06
						10.27
						10.42
						10.67
						10.70
						11.37
						11.50
						11.85
						12.28

740vph	776vph	812vph	852vph	900vph	988vph	1108vph
						12.80
						13.08
						13.32
						13.86
						14.69
						18.04
						20.86
						22.36

Appendix B: Headway Modelling Output.

B1: Extracted cumulative percentiles of generated headways

Percentiles	Hdy700	Hdy710	Hdy720	Hdy730	Hdy740	Hdy750	Hdy760	Hdy770	Hdy780	Hdy790	Hdy800	Hdy810
0	0.10	0.10	0.10	0.10	0.10	0.10	0.10	0.10	0.10	0.10	0.10	0.10
1	0.34	0.41	0.41	0.34	0.35	0.44	0.43	0.46	0.45	0.43	0.33	0.31
2	0.40	0.51	0.45	0.44	0.47	0.49	0.45	0.55	0.50	0.46	0.39	0.33
3	0.45	0.56	0.52	0.54	0.50	0.64	0.60	0.63	0.61	0.54	0.43	0.35
4	0.48	0.70	0.56	0.57	0.52	0.68	0.68	0.65	0.72	0.60	0.43	0.46
5	0.49	0.75	0.69	0.69	0.58	0.72	0.75	0.71	0.75	0.65	0.47	0.51
10	1.00	0.97	1.00	0.99	1.00	1.00	0.98	0.96	1.00	0.97	0.78	0.84
15	1.12	1.17	1.13	1.15	1.12	1.22	1.16	1.17	1.14	1.18	0.98	1.00
20	1.26	1.31	1.27	1.30	1.26	1.44	1.29	1.35	1.29	1.27	1.20	1.10
25	1.41	1.50	1.48	1.46	1.44	1.57	1.45	1.51	1.48	1.43	1.40	1.21
30	1.62	1.65	1.59	1.63	1.59	1.77	1.65	1.68	1.63	1.69	1.59	1.42
35	1.78	1.84	1.83	1.77	1.75	1.90	1.81	1.84	1.78	1.83	1.73	1.52
40	1.98	2.00	2.02	1.99	2.01	2.00	1.99	2.02	1.99	1.99	1.89	1.77
45	2.25	2.37	2.36	2.28	2.44	2.24	2.50	2.37	2.18	2.32	1.99	2.01
50	2.79	2.74	2.69	2.55	2.80	2.66	2.75	2.74	2.55	2.62	2.40	2.36
55	2.98	3.19	2.95	2.91	3.12	3.05	3.04	2.97	2.93	2.93	2.72	2.67
60	3.23	3.51	3.33	3.12	3.40	3.47	3.33	3.35	3.40	3.28	3.18	3.13
65	3.59	3.76	3.53	3.52	3.66	3.66	3.77	3.58	3.65	3.57	3.55	3.43
70	3.99	3.98	3.96	3.99	3.98	3.97	3.96	3.98	3.99	3.97	3.98	3.98
75	4.87	5.47	6.10	5.67	5.21	5.04	6.06	5.46	5.68	5.31	5.45	4.87
80	6.59	7.79	7.41	7.47	6.17	6.45	7.51	7.10	6.41	7.35	6.91	5.97
85	8.05	8.73	8.82	9.19	7.92	7.94	8.28	8.07	8.11	8.39	7.46	7.45
90	9.94	9.72	9.89	9.96	9.98	9.86	9.85	9.76	9.91	9.87	8.55	8.71
95	29.57	26.53	27.20	26.46	29.38	27.36	28.45	28.04	22.28	26.11	10.00	9.96
98	37.20	39.08	39.30	39.85	38.96	36.90	36.55	39.10	38.39	35.53	27.88	28.13
99	40.97	42.66	42.76	42.09	42.13	40.09	37.44	41.07	41.83	40.98	31.75	32.91
100	43.77	44.22	43.82	42.81	42.83	43.24	44.52	43.83	44.67	41.88	34.69	34.52

Percentiles	Hdy820	Hdy830	Hdy840	Hdy850	Hdy860	Hdy870	Hdy880	Hdy890	Hdy900	Hdy910	Hdy920	Hdy930
0	0.10	0.10	0.10	0.10	0.10	0.10	0.10	0.10	0.10	0.10	0.10	0.10
1	0.36	0.32	0.35	0.38	0.35	0.38	0.34	0.32	0.42	0.38	0.37	0.38
2	0.41	0.34	0.40	0.39	0.37	0.40	0.37	0.35	0.43	0.41	0.41	0.43
3	0.44	0.43	0.44	0.45	0.40	0.43	0.46	0.44	0.46	0.51	0.45	0.46
4	0.46	0.47	0.49	0.52	0.44	0.45	0.51	0.47	0.54	0.57	0.49	0.56
5	0.48	0.55	0.52	0.58	0.45	0.47	0.55	0.53	0.64	0.61	0.58	0.64
10	0.75	0.76	0.77	0.81	0.72	0.76	0.73	0.78	0.98	1.00	0.96	0.97
15	0.98	0.99	0.99	0.97	1.01	0.98	0.99	1.00	1.16	1.15	1.19	1.13
20	1.13	1.13	1.11	1.18	1.24	1.11	1.16	1.18	1.32	1.31	1.37	1.30
25	1.27	1.28	1.25	1.34	1.37	1.26	1.30	1.41	1.47	1.45	1.54	1.45
30	1.49	1.45	1.42	1.50	1.51	1.46	1.52	1.60	1.65	1.57	1.66	1.64
35	1.63	1.59	1.61	1.72	1.68	1.63	1.68	1.73	1.79	1.72	1.85	1.82
40	1.83	1.78	1.81	1.89	1.86	1.80	1.85	1.87	2.01	2.01	2.00	2.00
45	2.00	1.99	2.01	2.00	1.99	2.01	2.01	2.04	2.27	2.30	2.30	2.37
50	2.33	2.46	2.46	2.50	2.47	2.37	2.44	2.64	2.53	2.53	2.56	2.66
55	2.57	2.79	2.98	2.85	2.85	2.85	2.94	2.94	2.78	2.78	2.75	2.93
60	2.89	3.32	3.27	3.14	3.15	3.21	3.36	3.24	2.99	3.25	3.10	3.27
65	3.43	3.67	3.74	3.68	3.70	3.54	3.79	3.60	3.38	3.53	3.41	3.48
70	4.27	4.28	4.04	4.05	4.00	4.12	4.03	4.00	3.72	3.75	3.70	3.74
75	5.30	5.04	5.13	5.09	4.93	5.29	5.38	5.27	4.01	4.18	4.00	4.16
80	6.56	6.37	6.41	5.81	6.69	6.38	6.67	6.50	5.08	5.26	5.73	5.66
85	7.74	7.91	7.68	7.08	7.99	7.60	7.82	7.37	7.45	6.80	6.70	7.44
90	8.68	8.87	8.80	8.81	8.86	8.91	8.70	8.53	9.11	8.64	8.62	8.86
95	9.96	9.97	9.87	10.00	9.96	9.90	10.00	9.98	11.17	11.17	10.34	11.01
98	24.46	24.53	23.60	25.67	21.96	20.76	24.85	20.88	19.62	26.35	25.16	19.57
99	29.99	28.28	29.05	29.68	27.14	27.56	29.86	29.42	25.68	27.41	27.44	25.04
100	34.66	34.07	34.67	34.83	32.52	32.78	34.37	32.25	28.57	29.45	29.22	28.61

Percentiles	Hdy940	Hdy950	Hdy960	Hdy970	Hdy980	Hdy990	Hdy1000	Hdy1010	Hdy1020	Hdy1030	Hdy1040	Hdy1050
0	0.10	0.10	0.10	0.10	0.10	0.10	0.10	0.10	0.10	0.10	0.10	0.10
1	0.36	0.37	0.35	0.34	0.34	0.33	0.31	0.34	0.32	0.35	0.33	0.32
2	0.41	0.39	0.49	0.43	0.42	0.36	0.36	0.36	0.34	0.41	0.35	0.35
3	0.57	0.43	0.62	0.50	0.52	0.40	0.42	0.38	0.37	0.48	0.38	0.38
4	0.65	0.48	0.68	0.53	0.57	0.46	0.48	0.49	0.39	0.54	0.43	0.42
5	0.71	0.54	0.72	0.61	0.68	0.60	0.52	0.51	0.44	0.62	0.57	0.46
10	0.94	1.00	0.99	0.98	0.99	0.99	0.72	0.78	0.74	0.85	0.76	0.73
15	1.18	1.22	1.17	1.18	1.23	1.13	0.95	1.00	0.98	0.98	0.98	0.99
20	1.37	1.37	1.39	1.34	1.33	1.30	1.12	1.14	1.16	1.16	1.14	1.12
25	1.57	1.59	1.55	1.46	1.48	1.47	1.25	1.23	1.32	1.32	1.25	1.23
30	1.65	1.76	1.71	1.66	1.64	1.66	1.34	1.39	1.46	1.45	1.42	1.38
35	1.80	1.88	1.84	1.85	1.83	1.89	1.52	1.51	1.60	1.56	1.51	1.51
40	2.00	2.00	2.01	2.00	2.00	2.00	1.67	1.65	1.73	1.75	1.68	1.69
45	2.28	2.11	2.36	2.27	2.31	2.27	1.82	1.82	1.88	1.86	1.82	1.89
50	2.49	2.51	2.54	2.59	2.64	2.56	2.04	2.02	2.01	2.01	2.01	2.01
55	2.95	2.73	2.86	2.97	2.82	2.87	2.86	2.51	2.63	2.59	2.38	2.49
60	3.23	2.91	3.12	3.20	3.07	3.11	3.18	3.14	3.09	3.04	3.02	3.13
65	3.50	3.27	3.38	3.45	3.36	3.42	3.52	3.54	3.41	3.48	3.58	3.49
70	3.74	3.63	3.69	3.74	3.66	3.77	4.02	4.10	4.04	4.08	4.04	4.11
75	4.08	4.01	4.01	4.41	3.99	4.07	5.03	5.26	5.02	5.61	5.12	5.15
80	6.29	5.67	5.12	5.68	4.99	5.62	6.10	6.67	6.54	7.11	6.13	6.37
85	7.12	7.29	7.07	6.84	6.69	7.08	7.39	7.94	7.74	7.99	7.08	7.67
90	8.32	8.46	8.71	8.82	8.61	9.25	9.02	8.71	8.59	8.83	8.48	8.54
95	10.17	11.51	10.81	11.31	11.24	12.13	12.14	10.09	11.40	10.02	10.21	11.15
98	22.65	19.23	20.41	24.57	23.52	22.58	18.32	19.10	18.43	20.47	15.90	18.85
99	26.67	26.05	27.56	28.53	26.77	27.11	21.02	22.34	23.10	23.24	20.67	21.39
100	29.61	27.85	29.37	29.61	28.75	29.11	23.17	24.67	24.63	24.97	23.08	23.34

Percentiles	Hdy1060	Hdy1070	Hdy1080	Hdy1090	Hdy1100	Hdy1110	Hdy1120	Hdy1130	Hdy1140	Hdy1150	Hdy1160	Hdy1170
0	0.10	0.10	0.10	0.10	0.10	0.10	0.10	0.10	0.10	0.10	0.10	0.10
1	0.40	0.34	0.39	0.38	0.34	0.33	0.37	0.35	0.33	0.32	0.35	0.36
2	0.42	0.42	0.42	0.40	0.40	0.39	0.39	0.40	0.35	0.35	0.42	0.40
3	0.53	0.45	0.48	0.47	0.48	0.41	0.42	0.42	0.38	0.36	0.43	0.47
4	0.53	0.50	0.56	0.48	0.51	0.43	0.52	0.45	0.49	0.37	0.44	0.54
5	0.58	0.53	0.61	0.51	0.57	0.44	0.56	0.56	0.53	0.39	0.53	0.62
10	0.85	0.77	0.79	0.76	0.76	0.76	0.81	0.78	0.77	0.67	0.71	0.78
15	1.00	0.97	0.99	0.98	0.99	1.00	0.98	0.99	0.99	0.99	0.99	0.99
20	1.22	1.15	1.10	1.10	1.16	1.10	1.18	1.11	1.15	1.13	1.12	1.16
25	1.38	1.25	1.24	1.30	1.37	1.18	1.39	1.27	1.25	1.25	1.32	1.28
30	1.46	1.44	1.39	1.47	1.50	1.27	1.46	1.42	1.38	1.40	1.48	1.41
35	1.62	1.55	1.51	1.57	1.64	1.48	1.60	1.53	1.51	1.55	1.61	1.53
40	1.74	1.70	1.71	1.71	1.77	1.66	1.76	1.66	1.68	1.66	1.73	1.68
45	1.87	1.82	1.83	1.85	1.87	1.81	1.84	1.79	1.84	1.84	1.88	1.88
50	2.01	2.00	2.00	2.00	2.00	2.02	2.01	2.04	2.01	2.01	2.00	2.00
55	2.56	2.36	2.45	2.61	2.31	2.43	2.54	2.46	2.39	2.31	2.34	2.32
60	3.14	2.95	2.88	3.07	2.78	2.79	2.98	2.83	2.63	2.60	2.69	2.72
65	3.54	3.37	3.36	3.68	3.07	3.10	3.41	3.17	3.13	3.16	3.06	3.12
70	4.06	4.01	4.06	4.06	3.49	3.65	3.77	3.57	3.54	3.52	3.57	3.61
75	4.62	5.29	5.28	4.89	4.00	4.10	4.15	4.04	4.08	3.98	4.01	4.11
80	5.81	6.47	6.44	6.16	5.01	5.88	5.35	5.25	5.70	5.79	5.74	5.46
85	7.40	7.67	7.83	7.71	6.17	7.41	7.28	6.46	7.40	7.21	6.77	7.21
90	8.57	9.11	8.76	8.66	8.38	8.94	8.71	7.73	8.70	8.64	8.44	8.60
95	10.61	10.61	11.27	10.63	11.14	10.16	10.10	10.53	10.16	10.35	10.60	11.10
98	18.77	20.68	18.58	15.85	17.23	14.98	16.53	17.09	14.73	15.12	16.10	17.26
99	20.06	24.24	21.59	19.42	18.22	17.07	17.54	19.36	18.13	17.89	17.77	18.49
100	23.39	24.75	24.74	23.68	19.20	19.95	17.98	19.92	19.68	18.91	19.59	19.41

Percentiles	Hdy1180	Hdy1190	Hdy1200
0	0.10	0.10	0.10
1	0.33	0.36	0.35
2	0.38	0.39	0.42
3	0.42	0.43	0.47
4	0.47	0.55	0.49
5	0.52	0.62	0.52
10	0.65	0.79	0.67
15	0.96	0.97	0.99
20	1.11	1.13	1.15
25	1.23	1.22	1.33
30	1.44	1.42	1.52
35	1.59	1.54	1.65
40	1.79	1.71	1.74
45	1.90	1.84	1.87
50	2.00	2.03	2.00
55	2.35	2.39	2.35
60	3.00	2.81	2.70
65	3.33	3.25	3.15
70	3.69	3.57	3.56
75	4.08	4.08	4.00
80	5.38	5.43	5.43
85	6.65	7.07	6.83
90	7.98	8.26	7.98
95	10.38	10.67	11.59
98	16.38	18.16	16.30
99	17.86	19.51	19.75
100	19.56	19.98	19.97

B2: Hyperbolic models at different percentiles of vehicular interactions

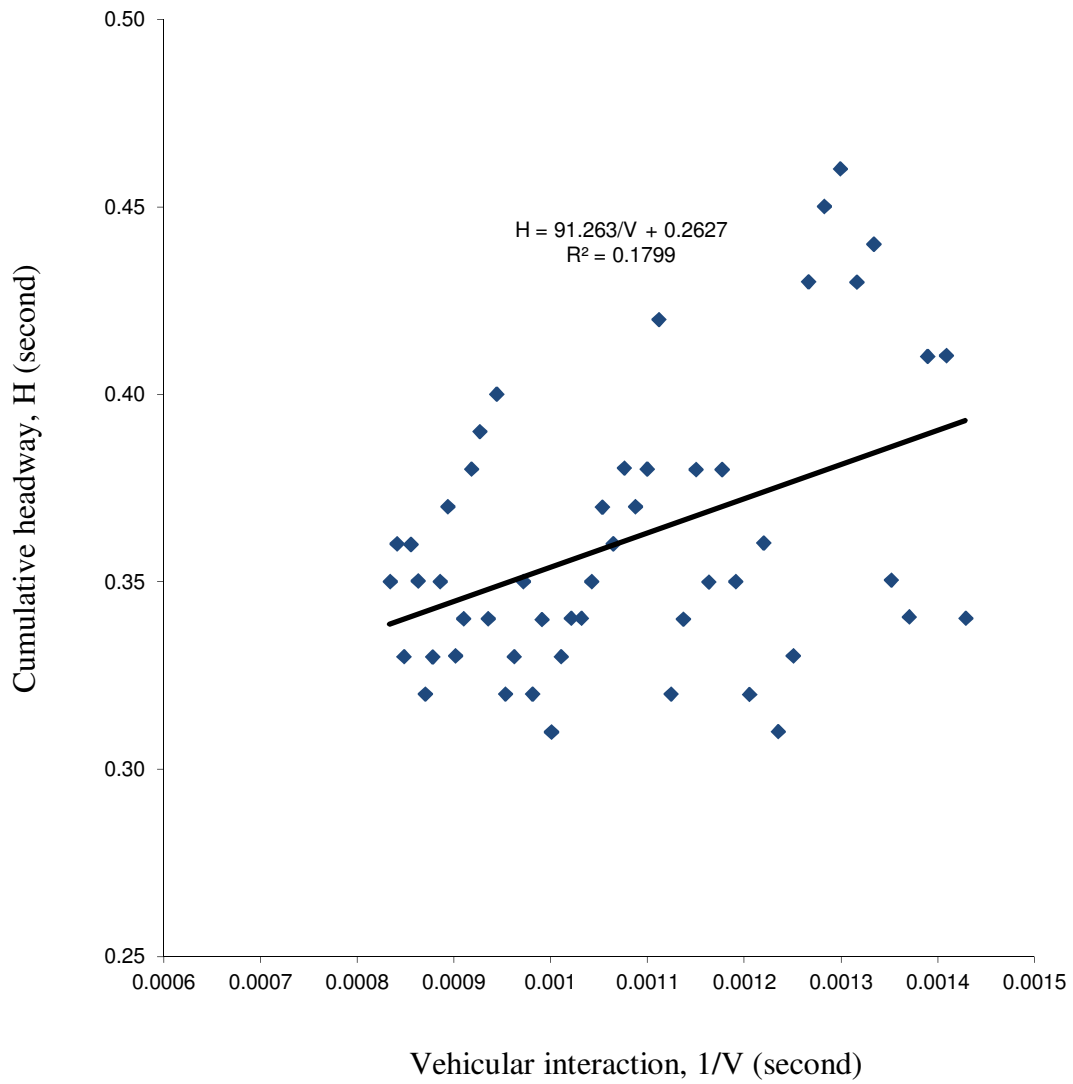

Fig. B2.1.Hyperbolic model at 1 percentile vehicular interaction

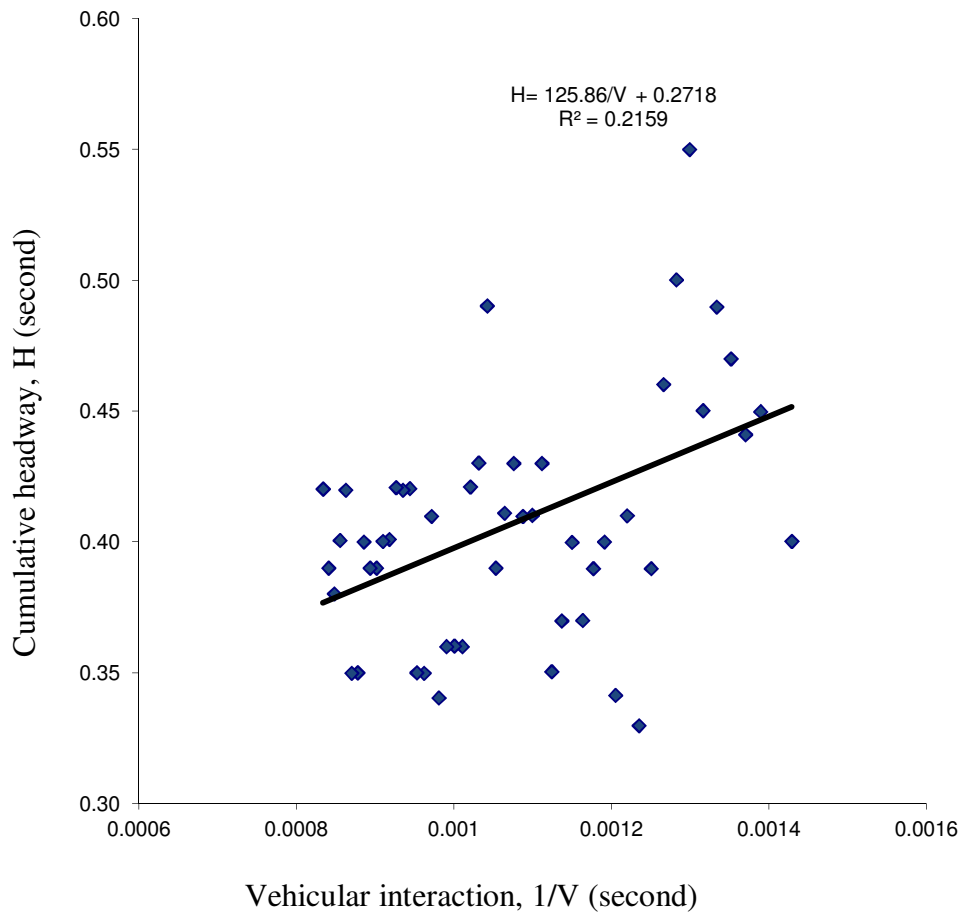

Fig. B2.2. Hyperbolic model at 2 percentile vehicular interaction

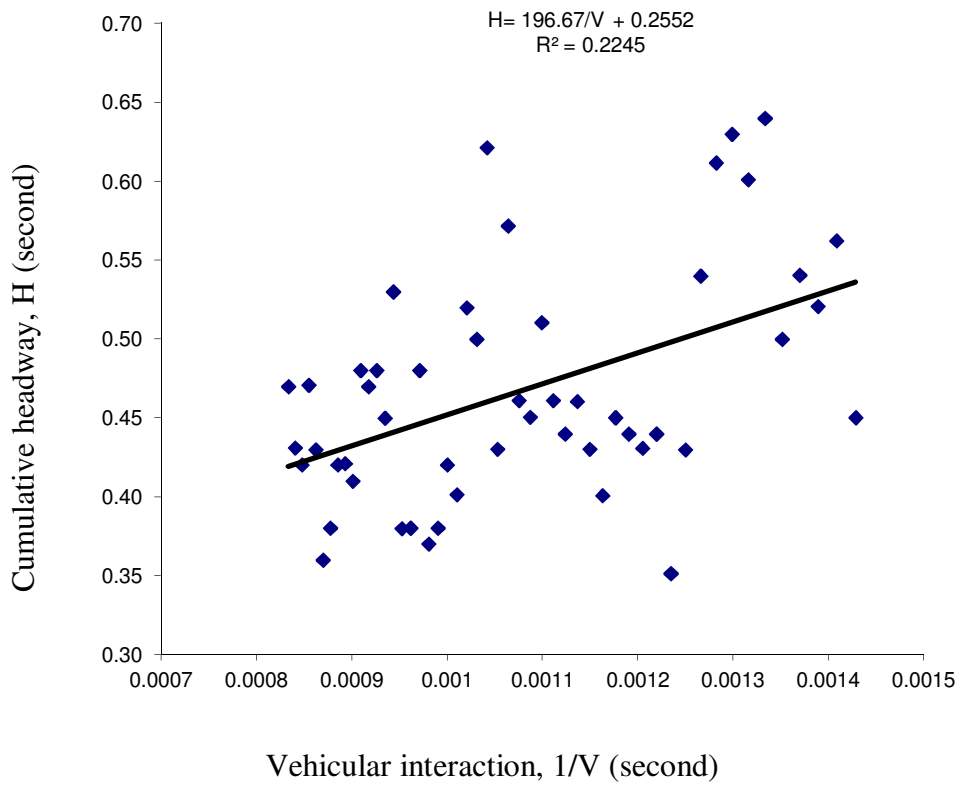

Fig. B2.3. Hyperbolic model at 3 percentile vehicular interaction

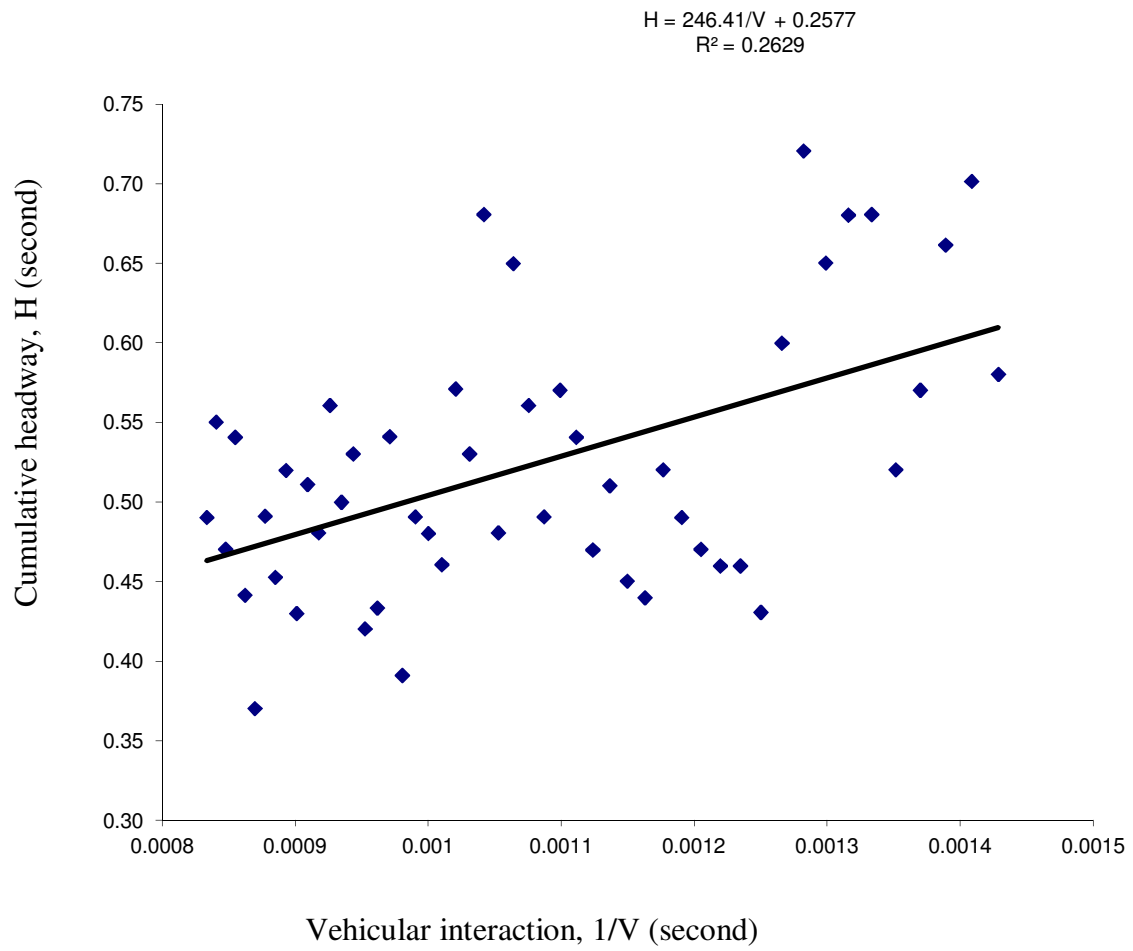

Fig. B2.4. Hyperbolic model at 4 percentile vehicular interaction

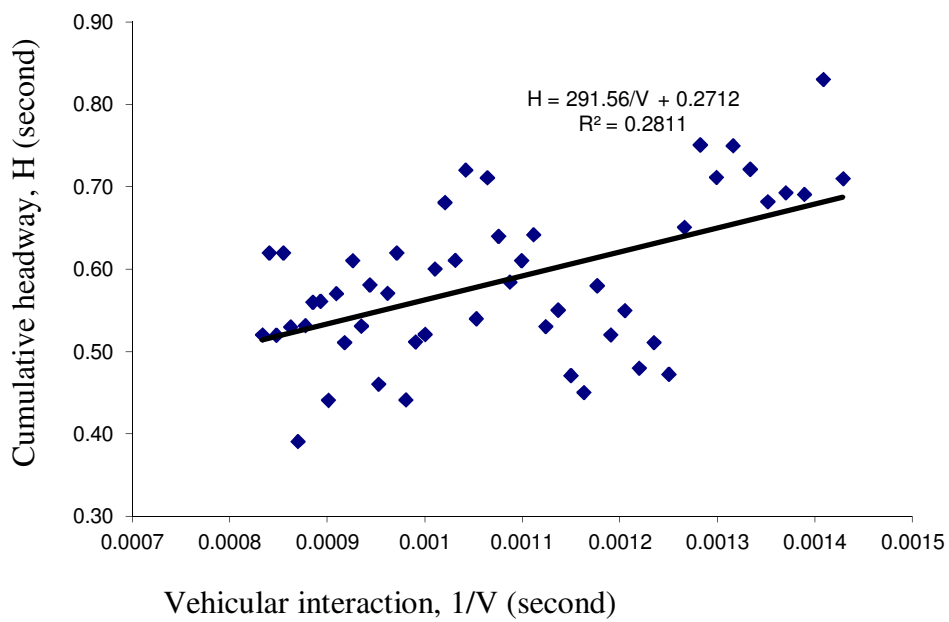

Fig. B2.5. Hyperbolic model at 5 percentile vehicular interaction

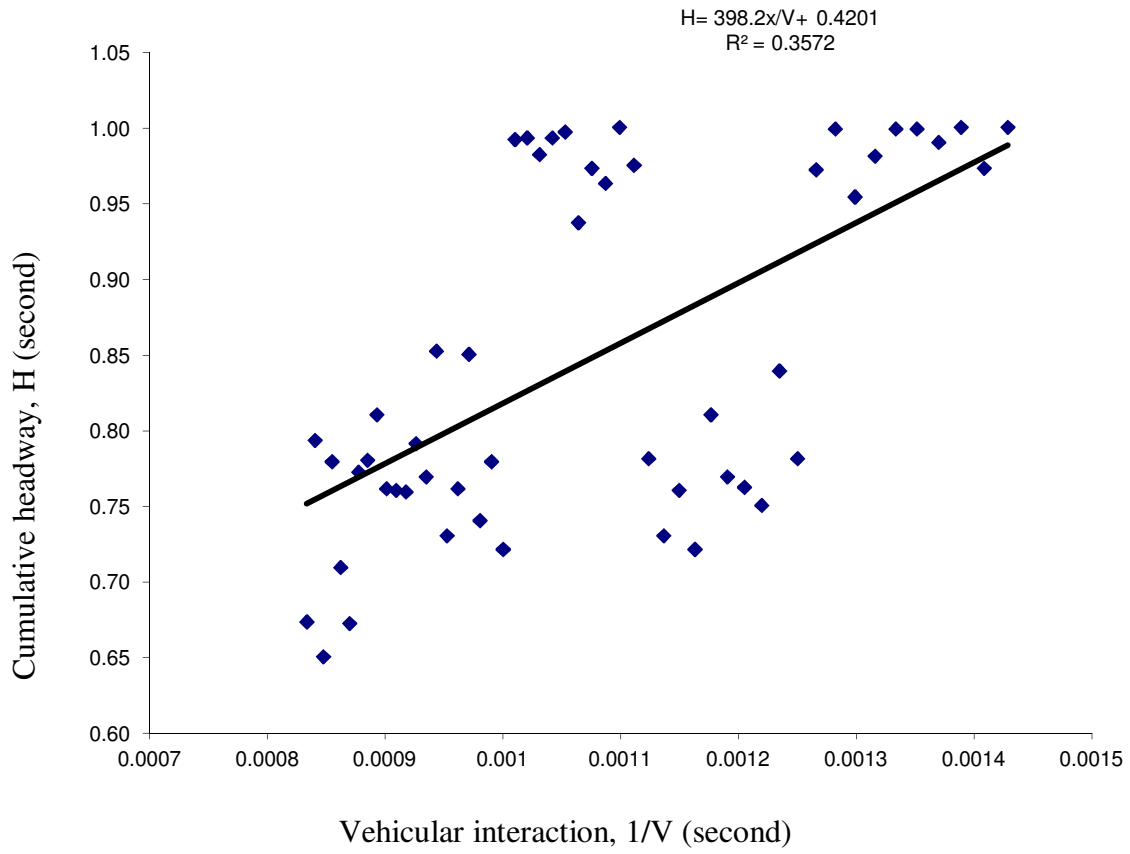

Fig. B2.6. Hyperbolic model at 10 percentile vehicular interaction

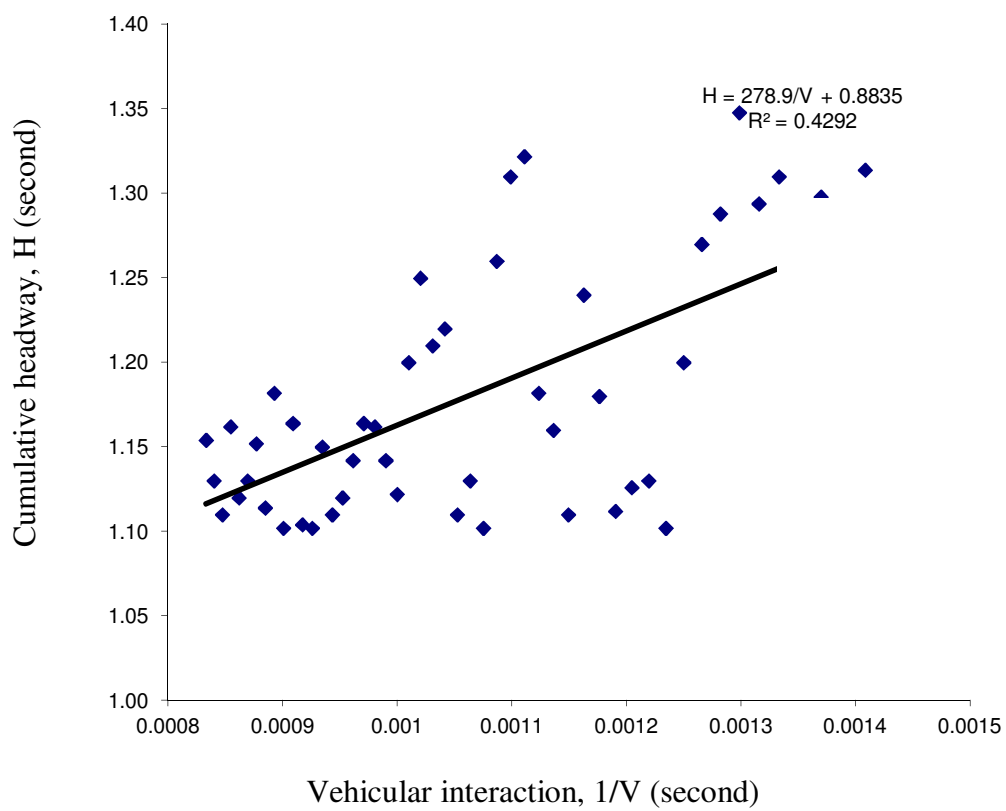

Fig. B2.7. Hyperbolic model at 20 percentile vehicular interaction

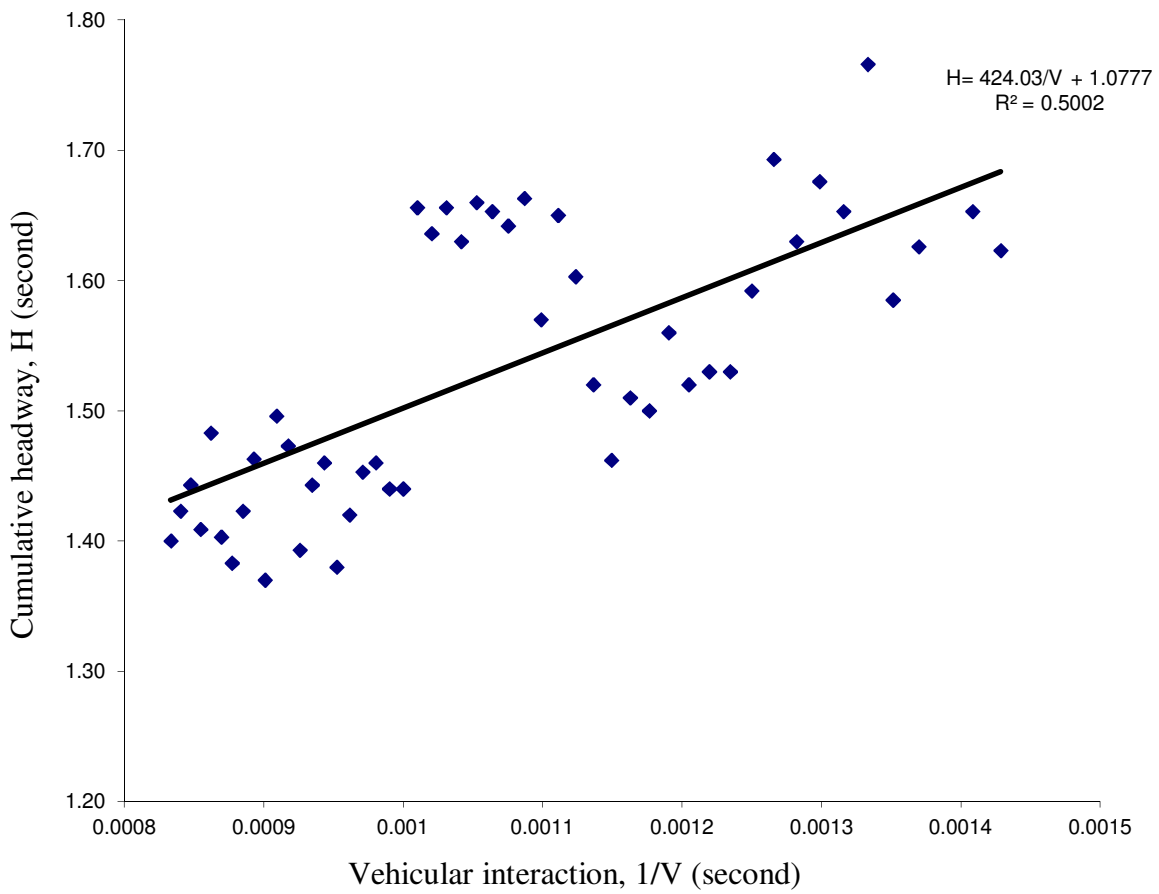

Fig. B2.8. Hyperbolic model at 30 percentile vehicular interaction

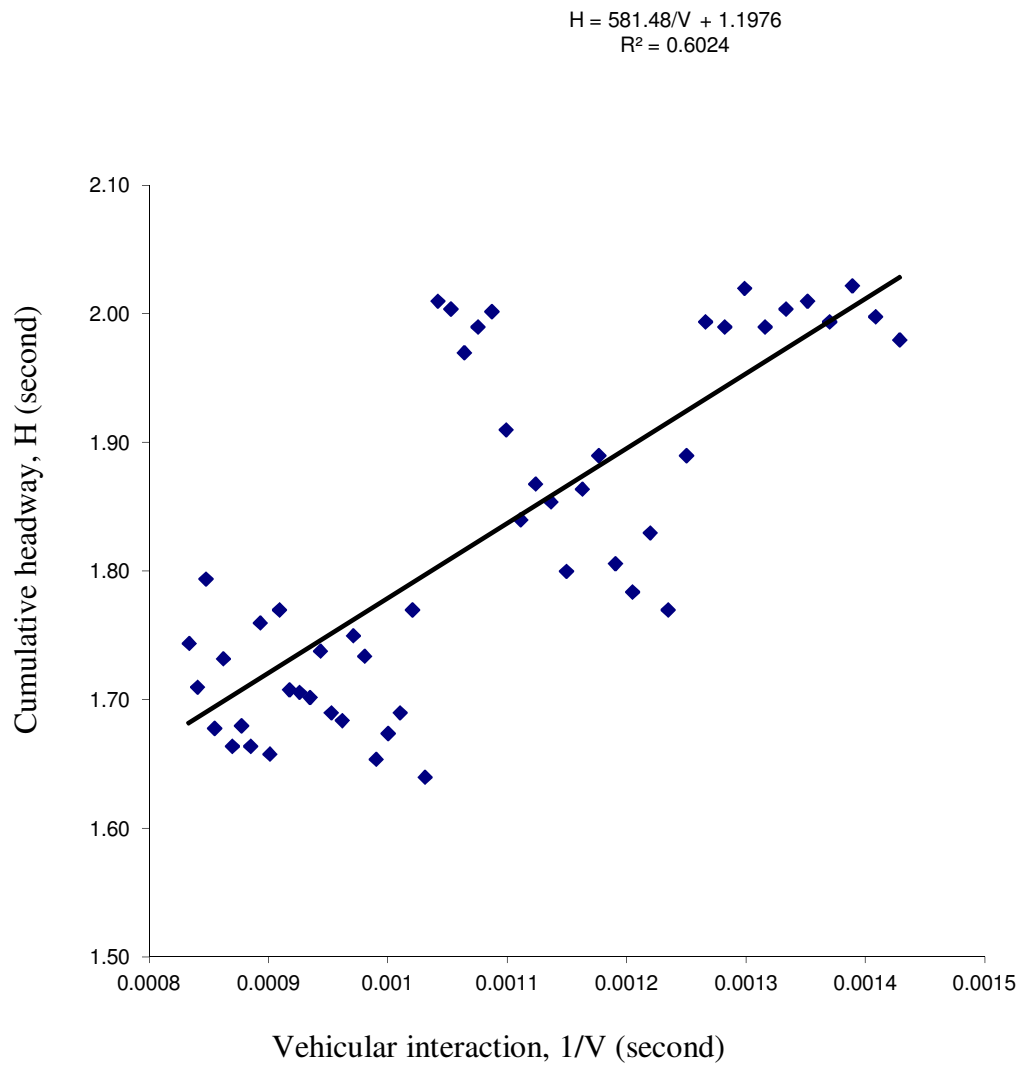

Fig. B2.9. Hyperbolic model at 40 percentile vehicular interaction

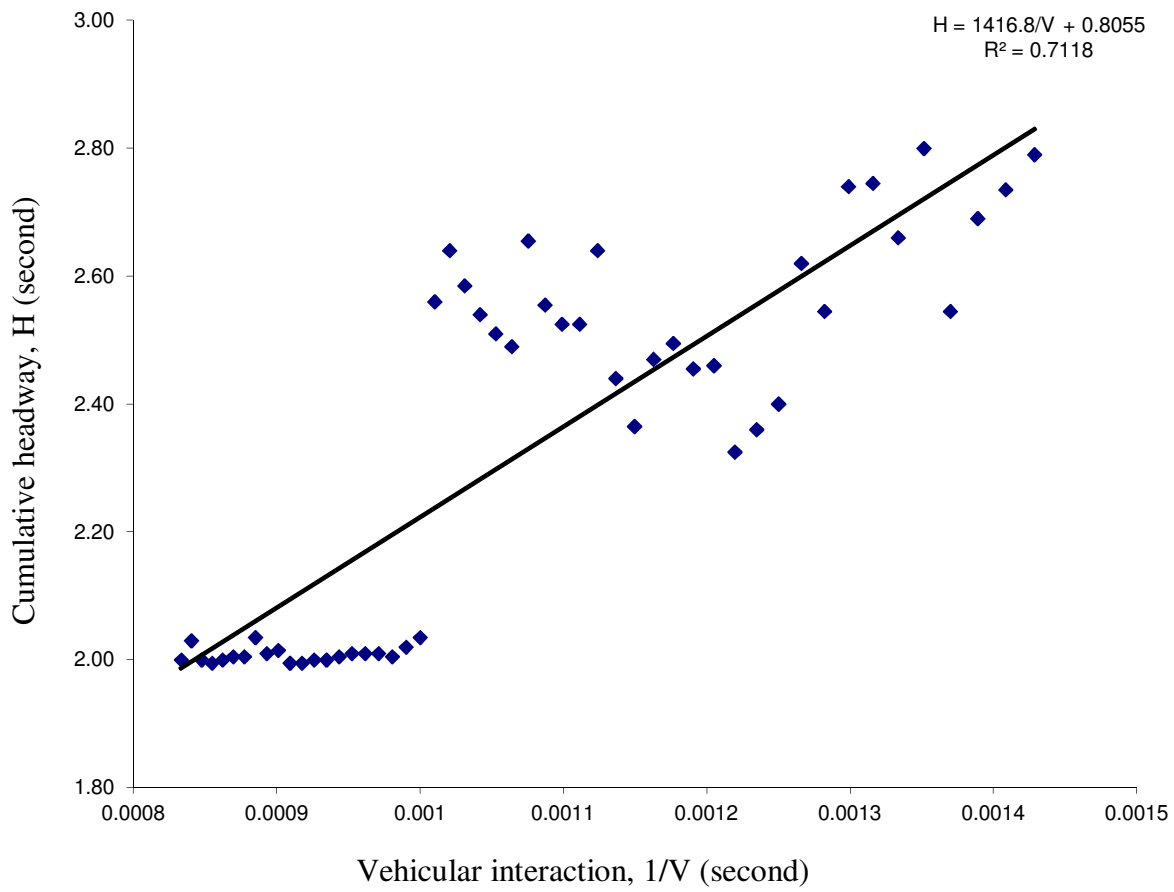

Fig. B2.10. Hyperbolic model at 50 percentile vehicular interaction

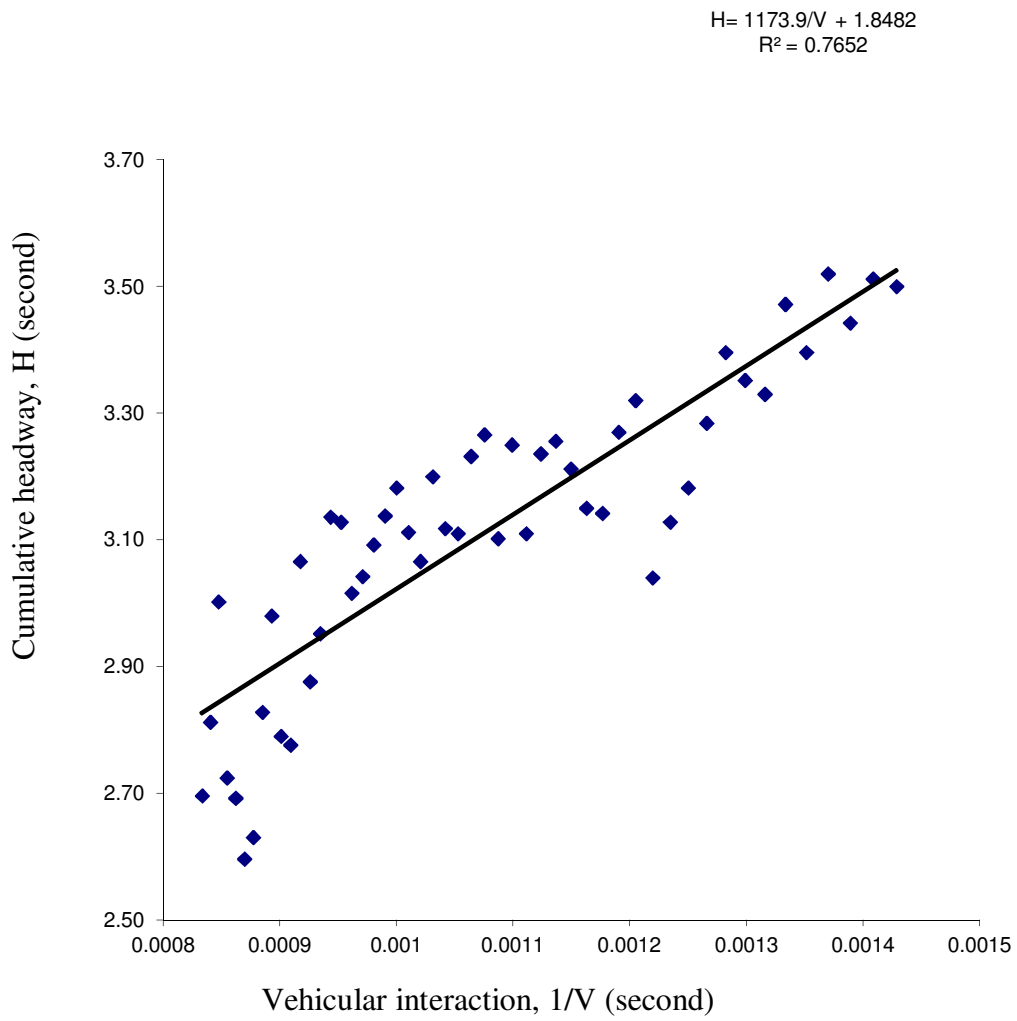

Fig. B2.11. Hyperbolic model at 60 percentile vehicular interaction

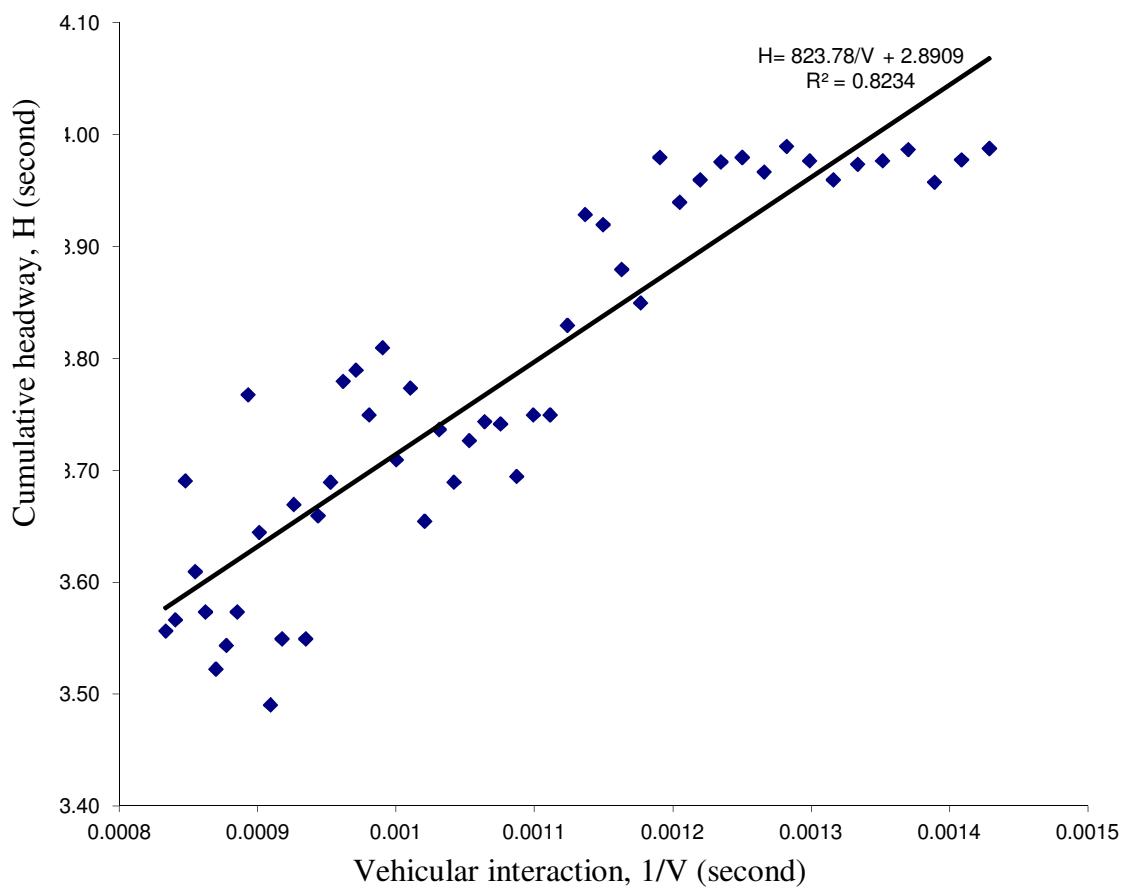

Fig. B2.12. Hyperbolic model at 70 percentile vehicular interaction

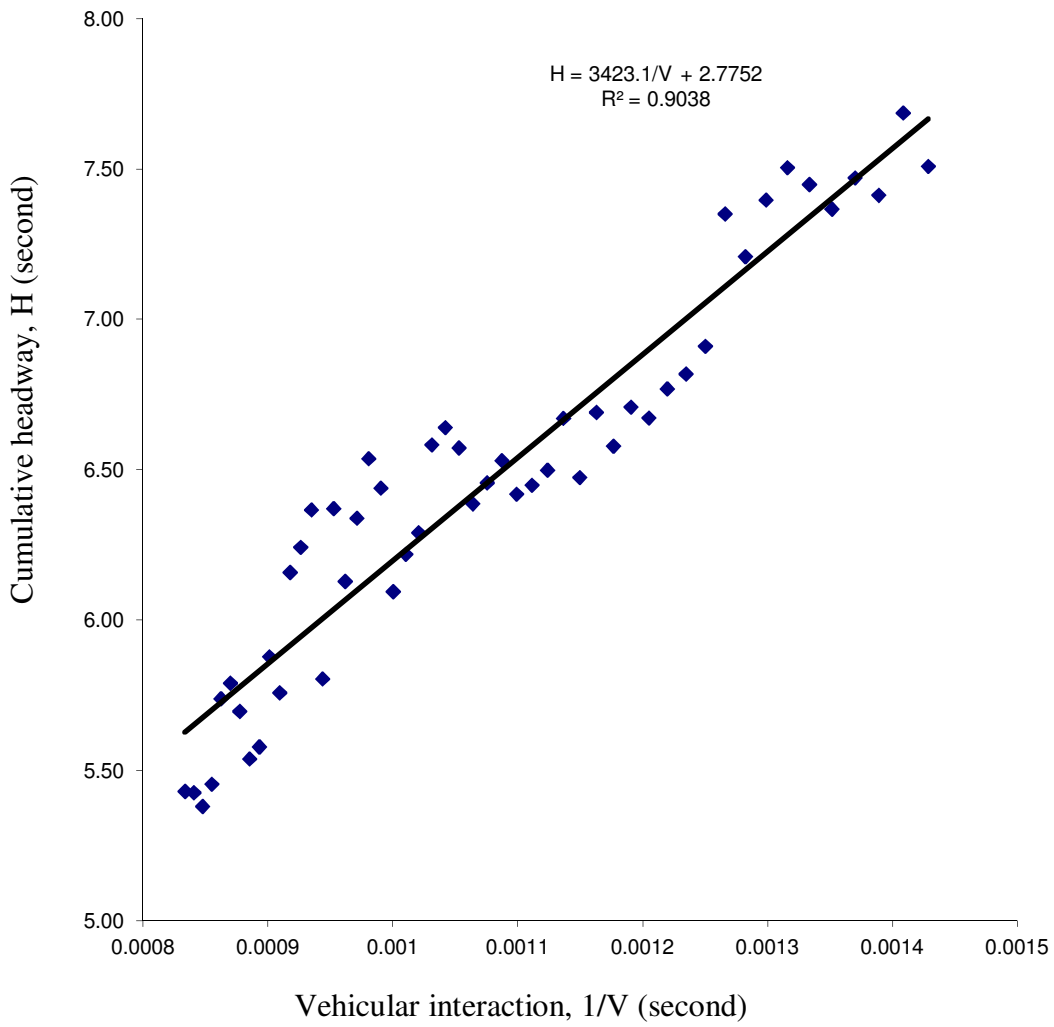

Fig. 2.13. Hyperbolic model at 80 percentile vehicular interaction

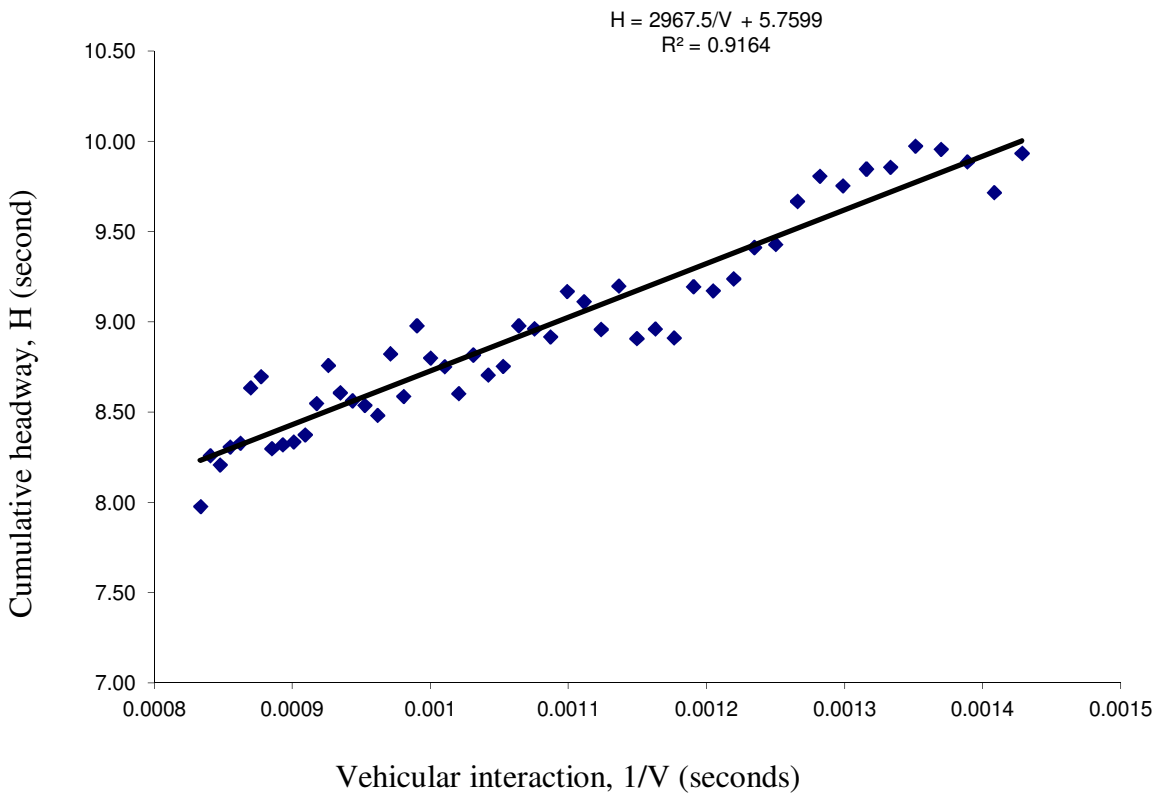

Fig. B2.14. Hyperbolic model at 90 percentile vehicular interaction

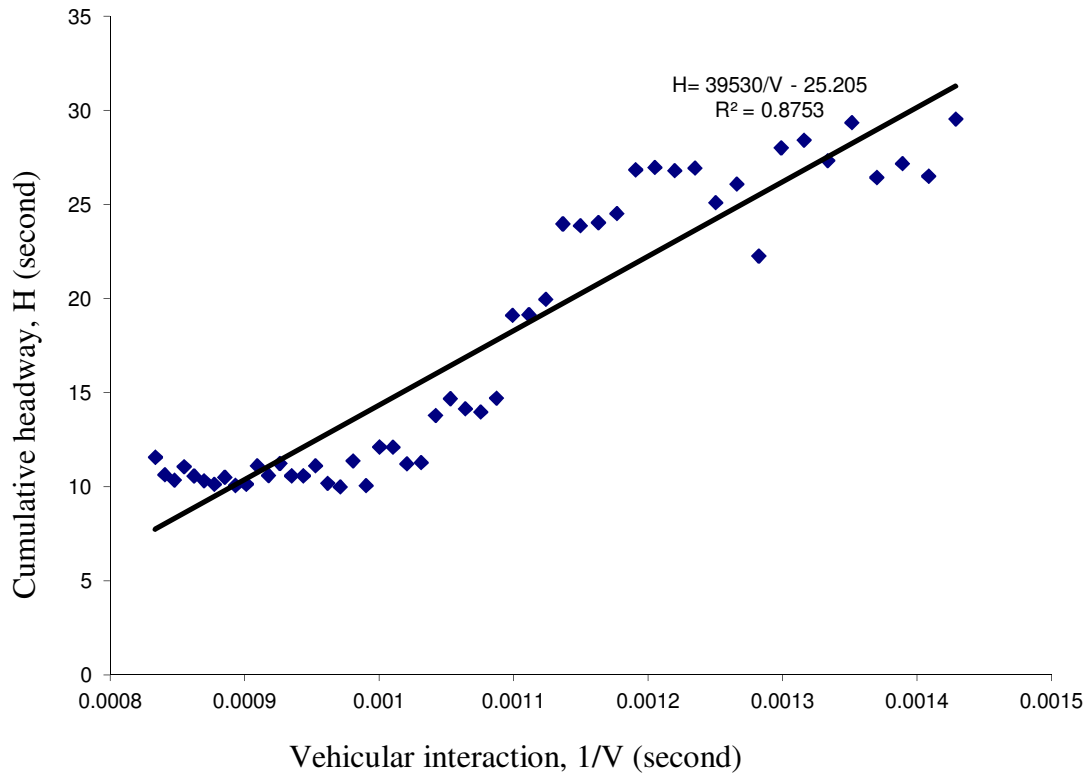

Fig. B2.15. Hyperbolic model at 95 percentile vehicular interaction

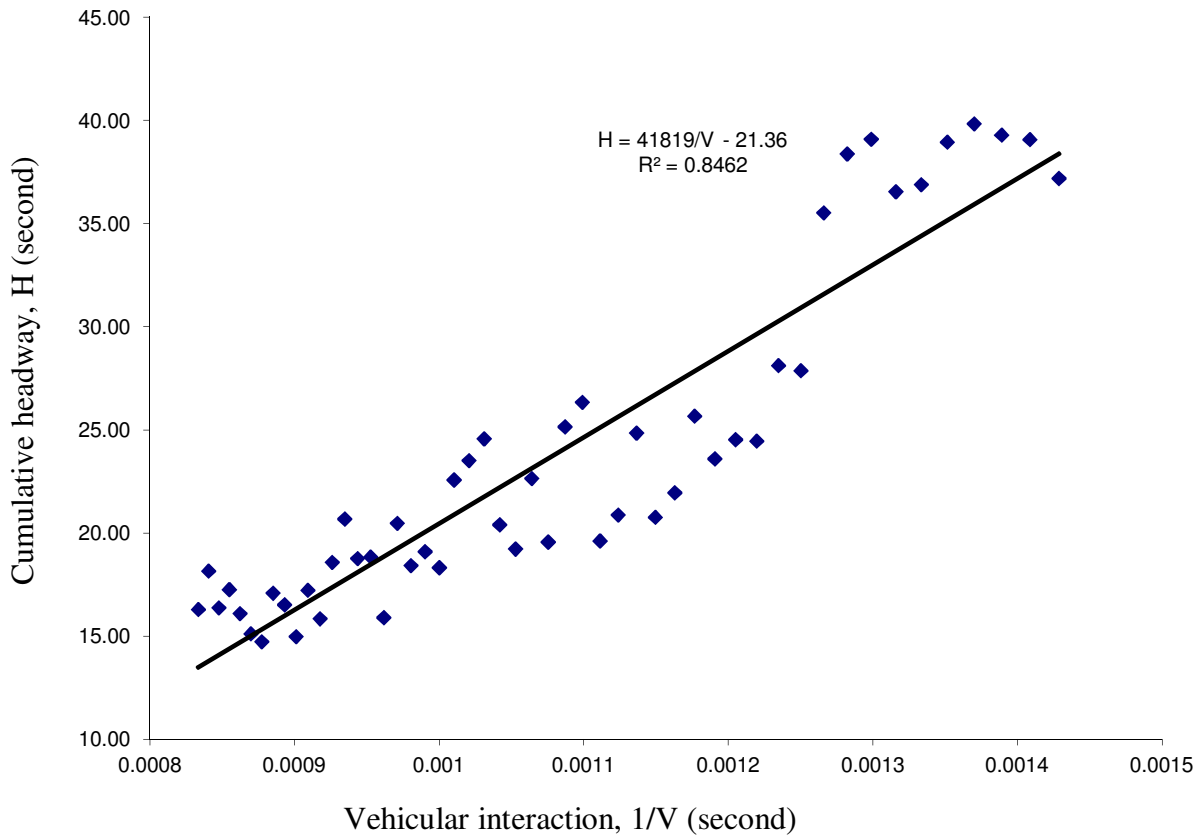

Fig. B2.16. Hyperbolic model at 98 percentile vehicular interaction

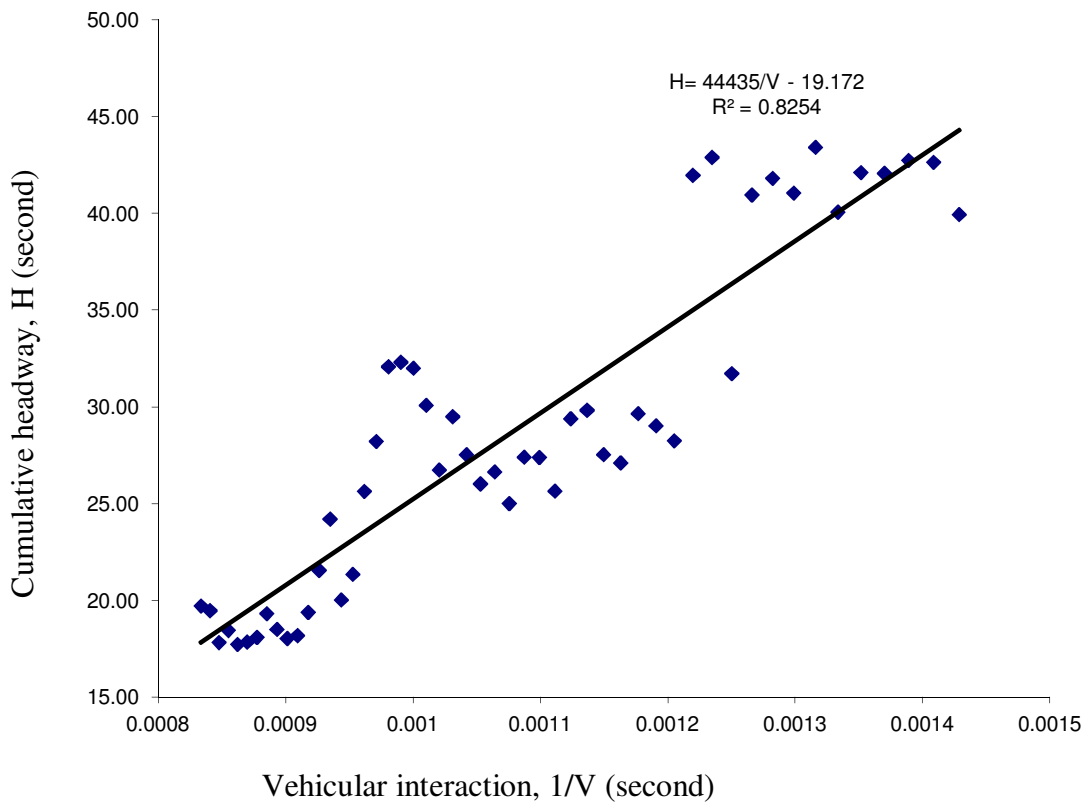

Fig. B2.17. Hyperbolic model at 99 percentile vehicular interaction

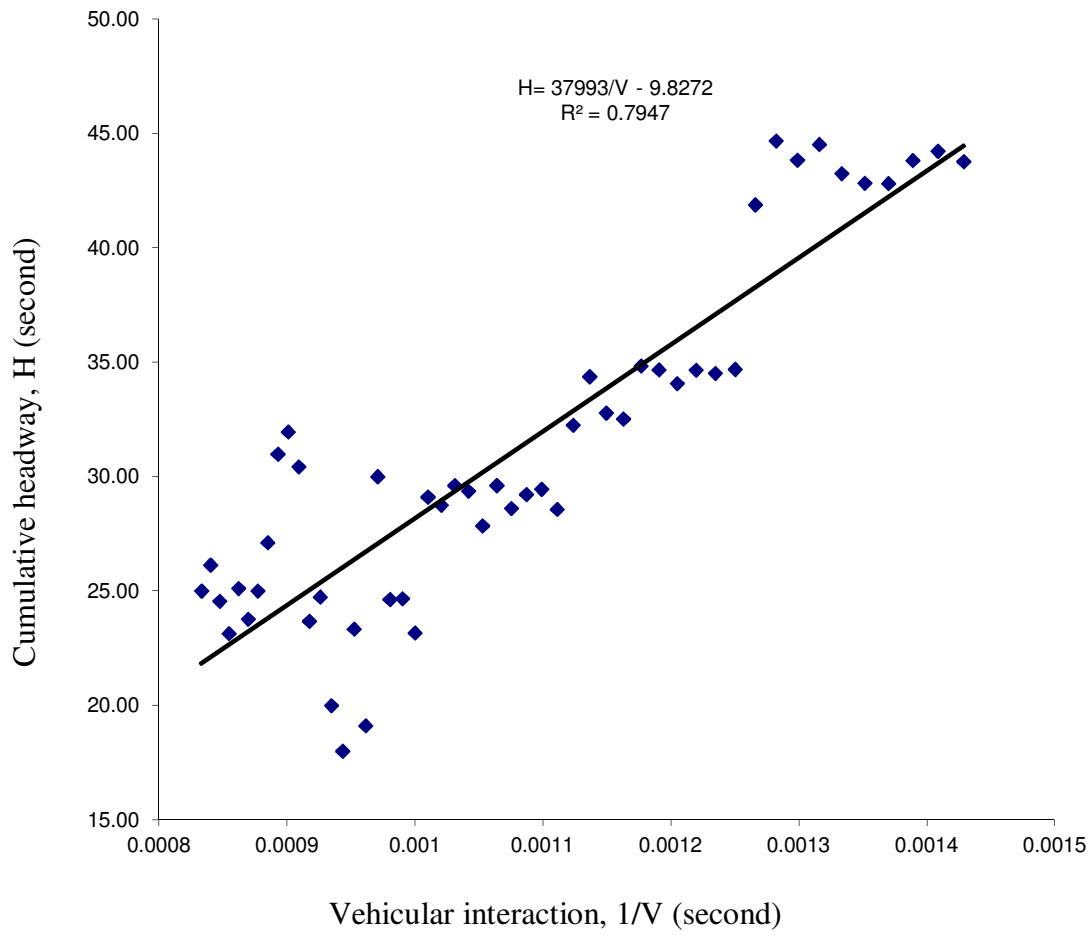

Fig. B2.18. Hyperbolic model at 100 percentile vehicular interaction

Appendix C: Kolmogorov-Smirnov Test

1. Traffic flow rate = 700 vph

The results of a Kolmogorov-Smirnov test performed at 10:25 on 9-FEB-2009

The maximum difference between the cumulative distributions, D , is: 0.1053 with a corresponding P of: 1.000

Data Set 1: (Field)

19 data points were entered

Mean = 6.751

95% confidence interval for actual Mean: 2.373 thru 11.13

Standard Deviation = 9.08

High = 29.3 Low = 0.100

Third Quartile = 10.2 First Quartile = 0.640

Median = 2.430

Average Absolute Deviation from Median = 5.89

John Tukey defined data points as *outliers* if they are $1.5 \times \text{IQR}$ above the third quartile or below the first quartile. Following Tukey, the following data points are outliers:

29.3 25.6

KS says it's unlikely this data is normally distributed: $P = 0.01$ where the normal distribution has mean = 9.736 and sdev = 10.33

KS finds the data is consistent with a log normal distribution: $P = 0.95$ where the log normal distribution has geometric mean = 2.423 and multiplicative sdev = 6.038

Items in Data Set 1:

0.100 0.430 0.510 0.540 0.640 0.710 0.980 1.35 1.75 2.43 3.07 4.12 5.33 6.68 10.2
13.8 20.9 25.6 29.3

Data Set 2: (Simulated)

19 data points were entered

Mean = 6.148

95% confidence interval for actual Mean: 1.890 thru 10.41

Standard Deviation = 8.83

High = 30.4 Low = 0.100

Third Quartile = 8.62 First Quartile = 0.570

Median = 1.840

Average Absolute Deviation from Median = 5.39

John Tukey defined data points as *outliers* if they are $1.5 \cdot \text{IQR}$ above the third quartile or below the first quartile. Following Tukey, the following data points are outliers:
30.4 23.6

KS says it's unlikely this data is normally distributed: $P = 0.01$ where the normal distribution has mean = 9.438 and sdev = 10.45

KS finds the data is consistent with a log normal distribution: $P = 0.96$ where the log normal distribution has geometric mean = 2.187 and multiplicative sdev = 5.894

Items in Data Set 2:

0.100 0.390 0.450 0.500 0.570 0.660 0.890 1.21 1.49 1.84 2.39 3.16 4.05 5.59 8.62
12.4 18.6 23.6 30.4

Data Reference: 726F

2. Traffic flow rate = 800 vph

The results of a Kolmogorov-Smirnov test performed at 10:58 on 9-FEB-2009
The maximum difference between the cumulative distributions, D , is: 0.1053 with a corresponding P of: 1.000

Data Set 1: (Field)

19 data points were entered

Mean = 7.058

95% confidence interval for actual Mean: 2.098 thru 12.02

Standard Deviation = 10.3

High = 35.2 Low = 0.100

Third Quartile = 9.36 First Quartile = 0.640

Median = 2.000

Average Absolute Deviation from Median = 6.21

John Tukey defined data points as *outliers* if they are $1.5 \times \text{IQR}$ above the third quartile or below the first quartile. Following Tukey, the following data points are outliers:

35.2 28.2

KS says it's unlikely this data is normally distributed: $P= 0.01$ where the normal distribution has mean= 10.95 and sdev= 12.22

KS finds the data is consistent with a log normal distribution: $P= 0.87$ where the log normal distribution has geometric mean= 2.485 and multiplicative sdev= 6.110

Items in Data Set 1:

0.100 0.490 0.530 0.580 0.640 0.760 1.02 1.30 1.61 2.00 2.69 3.66 4.62 6.44 9.36
13.8 21.1 28.2 35.2

Data Set 2: (Simulated)

19 data points were entered

Mean = 6.148

95% confidence interval for actual Mean: 1.890 thru 10.41

Standard Deviation = 8.83

High = 30.4 Low = 0.100

Third Quartile = 8.62 First Quartile = 0.570

Median = 1.840

Average Absolute Deviation from Median = 5.39

John Tukey defined data points as *outliers* if they are $1.5 \times \text{IQR}$ above the third quartile or below the first quartile. Following Tukey, the following data points are outliers:
30.4 23.6

KS says it's unlikely this data is normally distributed: $P = 0.01$ where the normal distribution has mean = 9.438 and sdev = 10.45

KS finds the data is consistent with a log normal distribution: $P = 0.96$ where the log normal distribution has geometric mean = 2.187 and multiplicative sdev = 5.894

Items in Data Set 2:

0.100 0.390 0.450 0.500 0.570 0.660 0.890 1.21 1.49 1.84 2.39 3.16 4.05 5.59 8.62
12.4 18.6 23.6 30.4

Data Reference: 7B09

3. Traffic flow rate = 900 vph

The results of a Kolmogorov-Smirnov test performed at 10:43 on 9-FEB-2009

The maximum difference between the cumulative distributions, D , is: 0.1579 with a corresponding P of: 0.956

Data Set 1: (Field)

19 data points were entered

Mean = 6.583

95% confidence interval for actual Mean: 1.970 thru 11.20

Standard Deviation = 9.57

High = 30.4 Low = 0.100

Third Quartile = 8.72 First Quartile = 0.700

Median = 2.090

Average Absolute Deviation from Median = 5.69

John Tukey defined data points as *outliers* if they are $1.5 \times \text{IQR}$ above the third quartile or below the first quartile. Following Tukey, the following data points are outliers:

30.4 27.6 22.3

KS says it's unlikely this data is normally distributed: $P = 0.00$ where the normal distribution has mean = 10.03 and sdev = 11.10

KS finds the data is consistent with a log normal distribution: $P = 0.98$ where the log normal distribution has geometric mean = 2.381 and multiplicative sdev = 5.907

Items in Data Set 1:

0.100 0.400 0.550 0.690 0.700 0.780 1.09 1.38 1.78 2.09 2.49 3.11 3.75 5.07 8.72
12.1 22.3 27.6 30.4

Data Set 2: (Simulated)

19 data points were entered

Mean = 5.980

95% confidence interval for actual Mean: 1.858 thru 10.10

Standard Deviation = 8.55

High = 29.5 Low = 0.100

Third Quartile = 8.42 First Quartile = 0.570

Median = 1.820

Average Absolute Deviation from Median = 5.23

John Tukey defined data points as *outliers* if they are $1.5 \cdot \text{IQR}$ above the third quartile or below the first quartile. Following Tukey, the following data points are outliers:
29.5 22.7

KS says it's unlikely this data is normally distributed: $P = 0.01$ where the normal distribution has mean = 9.160 and sdev = 10.12

KS finds the data is consistent with a log normal distribution: $P = 0.97$ where the log normal distribution has geometric mean = 2.148 and multiplicative sdev = 5.839

Items in Data Set 2:

0.100 0.380 0.440 0.500 0.570 0.650 0.890 1.20 1.47 1.82 2.35 3.09 3.98 5.47 8.42
12.2 17.9 22.7 29.5

Data Reference: 77B9

4. Traffic flow rate = 1000 vph

The results of a Kolmogorov-Smirnov test performed at 10:47 on 9-FEB-2009

The maximum difference between the cumulative distributions, D , is: 0.0526 with a corresponding P of: 1.000

Data Set 1: (Field)

19 data points were entered

Mean = 5.556

95% confidence interval for actual Mean: 1.754 thru 9.359

Standard Deviation = 7.89

High = 29.1 Low = 0.100

Third Quartile = 7.86 First Quartile = 0.580

Median = 1.820

Average Absolute Deviation from Median = 4.83

John Tukey defined data points as *outliers* if they are $1.5 \times \text{IQR}$ above the third quartile or below the first quartile. Following Tukey, the following data points are outliers:

29.1 19.1

KS says it's unlikely this data is normally distributed: $P = 0.01$ where the normal distribution has mean = 8.620 and sdev = 9.592

KS finds the data is consistent with a log normal distribution: $P = 0.99$ where the log normal distribution has geometric mean = 2.029 and multiplicative sdev = 5.749

Items in Data Set 1:

0.100 0.330 0.380 0.450 0.580 0.670 0.880 1.15 1.42 1.82 2.34 2.94 4.30 5.38 7.86
11.9 14.9 19.1 29.1

Data Set 2: (Simulated)

19 data points were entered

Mean = 5.897

95% confidence interval for actual Mean: 1.841 thru 9.954

Standard Deviation = 8.42

High = 29.1 Low = 0.100

Third Quartile = 8.32 First Quartile = 0.560

Median = 1.810

Average Absolute Deviation from Median = 5.15

John Tukey defined data points as *outliers* if they are $1.5 \cdot \text{IQR}$ above the third quartile or below the first quartile. Following Tukey, the following data points are outliers:
29.1 22.3

KS says it's unlikely this data is normally distributed: $P = 0.01$ where the normal distribution has mean = 9.024 and sdev = 9.956

KS finds the data is consistent with a log normal distribution: $P = 0.96$ where the log normal distribution has geometric mean = 2.128 and multiplicative sdev = 5.812

Items in Data Set 2:

0.100 0.380 0.440 0.490 0.560 0.650 0.880 1.19 1.46 1.81 2.33 3.06 3.95 5.41 8.32
12.0 17.6 22.3 29.1

Data Reference: 7870

5. Traffic flow rate = 1100 vph

The results of a Kolmogorov-Smirnov test performed at 10:56 on 9-FEB-2009

The maximum difference between the cumulative distributions, D , is: 0.0526 with a corresponding P of: 1.000

Data Set 1: (Field)

19 data points were entered

Mean = 4.862

95% confidence interval for actual Mean: 1.646 thru 8.077

Standard Deviation = 6.67

High = 22.4 Low = 0.100

Third Quartile = 7.30 First Quartile = 0.510

Median = 1.570

Average Absolute Deviation from Median = 4.18

John Tukey defined data points as *outliers* if they are $1.5 \times \text{IQR}$ above the third quartile or below the first quartile. Following Tukey, the following data points are outliers: 22.4 18.7

KS says it's unlikely this data is normally distributed: $P = 0.01$ where the normal distribution has mean = 7.200 and sdev = 7.739

KS finds the data is consistent with a log normal distribution: $P = 0.93$ where the log normal distribution has geometric mean = 1.877 and multiplicative sdev = 5.424

Items in Data Set 1:

0.100 0.380 0.390 0.450 0.510 0.580 0.820 1.12 1.30 1.57 1.95 2.57 3.38 4.70 7.30
10.7 13.6 18.7 22.4

Data Set 2: (Simulated)

19 data points were entered

Mean = 5.821

95% confidence interval for actual Mean: 1.828 thru 9.813

Standard Deviation = 8.28

High = 28.7 Low = 0.100

Third Quartile = 8.23 First Quartile = 0.560

Median = 1.800

Average Absolute Deviation from Median = 5.08

John Tukey defined data points as *outliers* if they are $1.5 \cdot \text{IQR}$ above the third quartile or below the first quartile. Following Tukey, the following data points are outliers:
28.7 21.9

KS says it's unlikely this data is normally distributed: $P = 0.01$ where the normal distribution has mean = 8.896 and sdev = 9.801

KS finds the data is consistent with a log normal distribution: $P = 0.96$ where the log normal distribution has geometric mean = 2.114 and multiplicative sdev = 5.781

Items in Data Set 2:

0.100 0.380 0.440 0.490 0.560 0.650 0.880 1.19 1.45 1.80 2.31 3.03 3.92 5.36 8.23
11.9 17.3 21.9 28.7

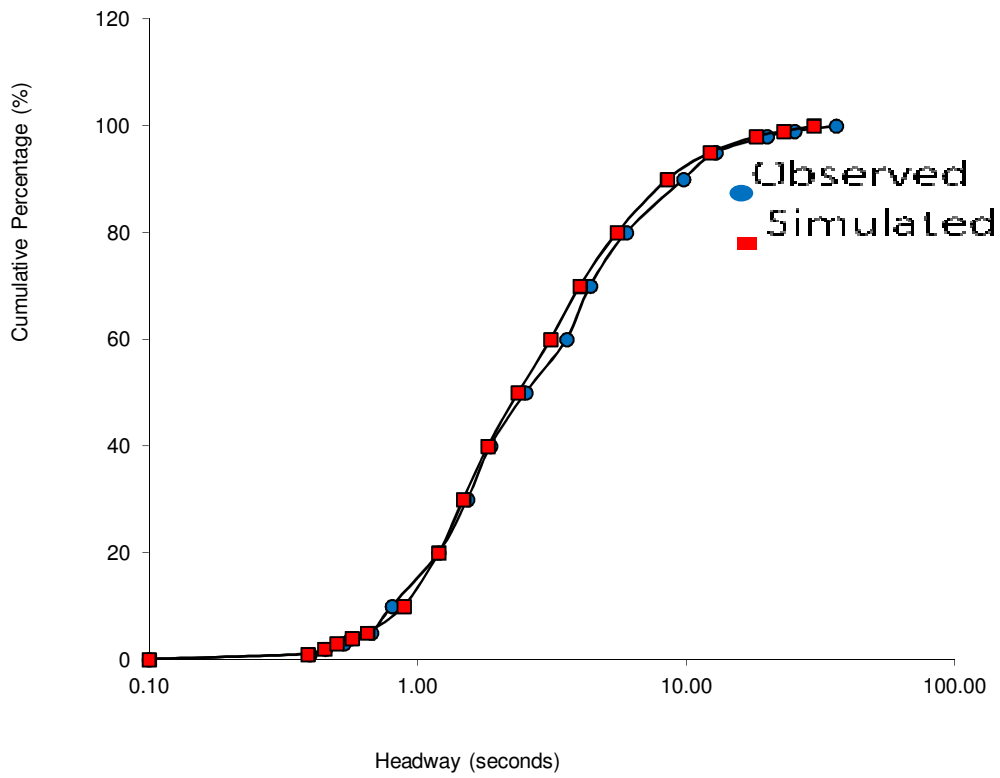

Fig. C.1.1. Comparison of field and simulated headway distributions for flow rate of 700 vph

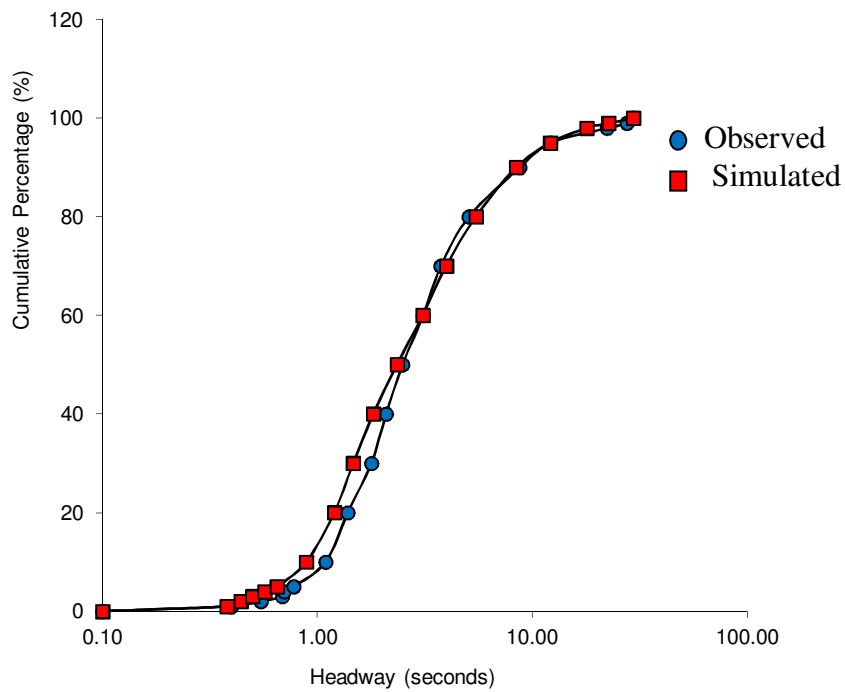

Fig. C1.2. Comparison of observed and simulated headway distributions for flow rate of 800 vph

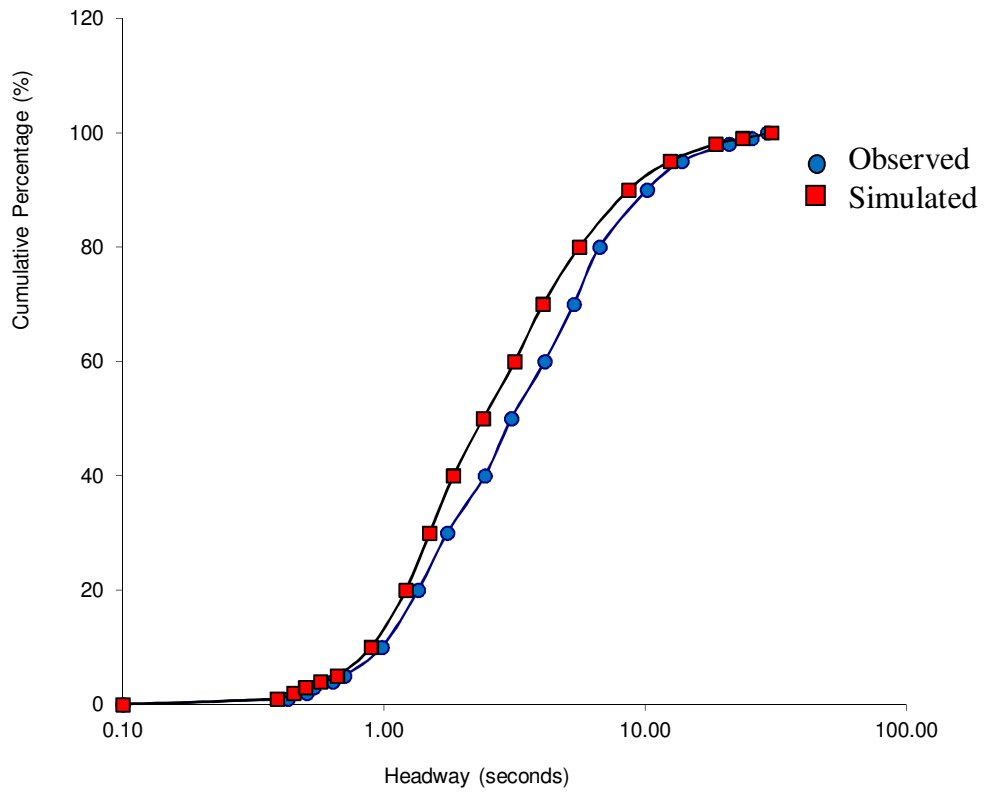

Fig. C1.3. Comparison of observed and simulated headway distributions for flow rate of 900 vph on two-lane highways

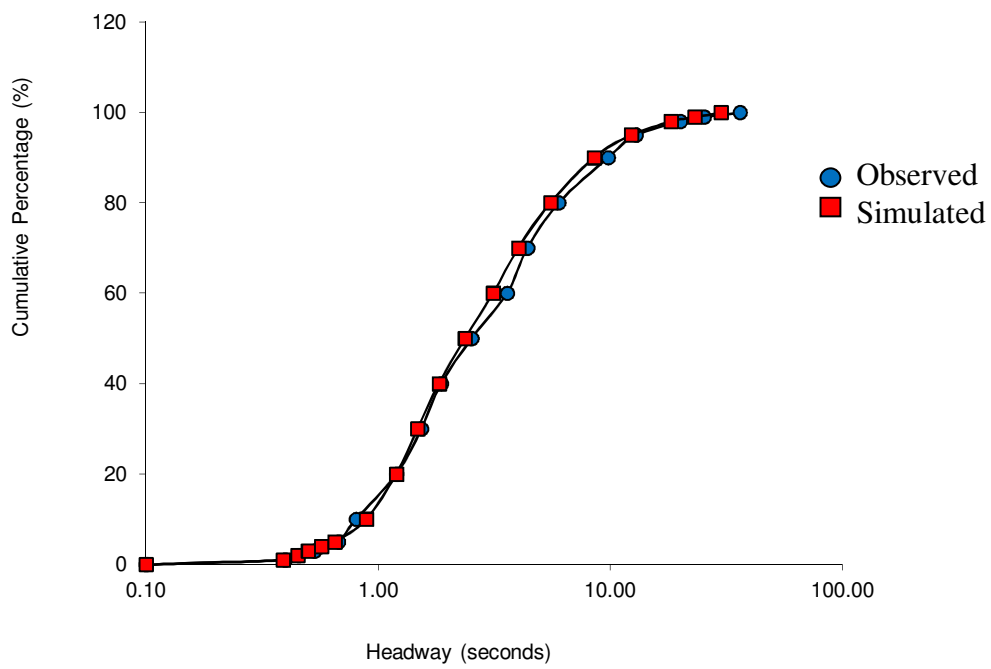

Fig. C1.4. Comparison of observed and simulated headway distributions for flow rate of 1000 vph

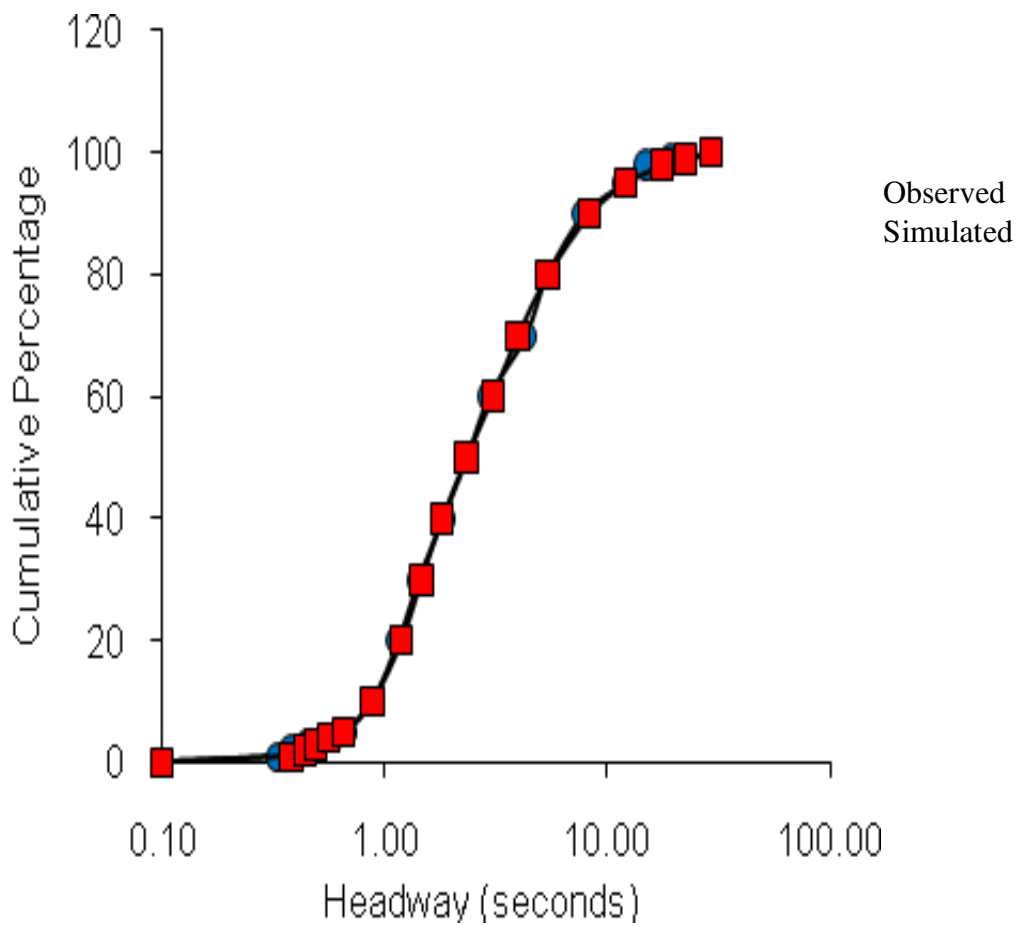

Fig. C1.5. Comparison of observed and simulated headway distributions for flow rate of 1100 vph

Appendix D: Traffic Flow Simulator Output

1. Simulated traffic flow with minimum and maximum headways of 1 and 2 seconds respectively

Initial Headway: 1662

Vehicle Release: 1 at 1.0 seconds of observation.

Headway: 1040

Vehicle Release: 2 at 2.0 seconds of observation.

Headway: 1469

Vehicle Release: 3 at 4.0 seconds of observation.

Headway: 1216

Vehicle Release: 4 at 5.0 seconds of observation.

Headway: 1298

Vehicle Release: 5 at 6.0 seconds of observation.

Headway: 1109

Vehicle Release: 6 at 7.0 seconds of observation.

Headway: 1120

Vehicle Release: 7 at 9.0 seconds of observation.

Headway: 1590

Vehicle Release: 8 at 10.0 seconds of observation.

Headway: 1473

Vehicle Release: 9 at 12.0 seconds of observation.

Headway: 1721

Vehicle Release: 10 at 13.0 seconds of observation.

Headway: 1385

Vehicle Release: 11 at 15.0 seconds of observation.

Headway: 1319

Vehicle Release: 12 at 16.0 seconds of observation.

Headway: 1087

Vehicle Release: 13 at 17.0 seconds of observation.

Headway: 1133

Vehicle Release: 14 at 18.0 seconds of observation.

Headway: 1226

Vehicle Release: 15 at 20.0 seconds of observation.

Headway: 1260

Vehicle Release: 16 at 21.0 seconds of observation.

Headway: 1400

Vehicle Release: 17 at 22.0 seconds of observation.

Headway: 1020

Vehicle Release: 18 at 23.0 seconds of observation.

Headway: 1741

Vehicle Release: 19 at 25.0 seconds of observation.

Headway: 1261

Vehicle Release: 20 at 26.0 seconds of observation.

Headway: 1490

Vehicle Release: 21 at 28.0 seconds of observation.

Headway: 1934

Vehicle Release: 22 at 30.0 seconds of observation.

Headway: 1631

Vehicle Release: 23 at 31.0 seconds of observation.

Headway: 1680

Vehicle Release: 24 at 33.0 seconds of observation.

Headway: 1871
Vehicle Release: 25 at 35.0 seconds of observation.
Headway: 1330
Vehicle Release: 26 at 36.0 seconds of observation.
Headway: 1281
Vehicle Release: 27 at 38.0 seconds of observation.
Headway: 1048
Vehicle Release: 28 at 39.0 seconds of observation.
Headway: 1078
Vehicle Release: 29 at 40.0 seconds of observation.
Headway: 1637
Vehicle Release: 30 at 41.0 seconds of observation.
Headway: 1598
Vehicle Release: 31 at 43.0 seconds of observation.
Headway: 1297
Vehicle Release: 32 at 44.0 seconds of observation.
Headway: 1902
Vehicle Release: 33 at 46.0 seconds of observation.
Headway: 1091
Vehicle Release: 34 at 47.0 seconds of observation.
Headway: 1613
Vehicle Release: 35 at 49.0 seconds of observation.
Headway: 1131
Vehicle Release: 36 at 50.0 seconds of observation.
Headway: 1979
Vehicle Release: 37 at 52.0 seconds of observation.
Headway: 1096
Vehicle Release: 38 at 53.0 seconds of observation.
Headway: 1371
Vehicle Release: 39 at 55.0 seconds of observation.
Headway: 1164
Vehicle Release: 40 at 56.0 seconds of observation.
Headway: 1831
Vehicle Release: 41 at 58.0 seconds of observation.
Headway: 1765
Vehicle Release: 42 at 59.0 seconds of observation.
Headway: 1302
Vehicle Release: 43 at 61.0 seconds of observation.
Headway: 1951
Vehicle Release: 44 at 63.0 seconds of observation.
Headway: 1821
Vehicle Release: 45 at 65.0 seconds of observation.
Headway: 1965
Vehicle Release: 46 at 66.0 seconds of observation.
Headway: 1616
Vehicle Release: 47 at 68.0 seconds of observation.
Headway: 1376
Vehicle Release: 48 at 69.0 seconds of observation.
Headway: 1232
Vehicle Release: 49 at 71.0 seconds of observation.

Headway: 1328
Vehicle Release: 50 at 72.0 seconds of observation.
Headway: 1851
Vehicle Release: 51 at 74.0 seconds of observation.
Headway: 1447
Vehicle Release: 52 at 75.0 seconds of observation.
Headway: 1557
Vehicle Release: 53 at 77.0 seconds of observation.
Headway: 1862
Vehicle Release: 54 at 79.0 seconds of observation.
Headway: 1245
Vehicle Release: 55 at 80.0 seconds of observation.
Headway: 1233
Vehicle Release: 56 at 81.0 seconds of observation.
Headway: 1212
Vehicle Release: 57 at 83.0 seconds of observation.
Headway: 1223
Vehicle Release: 58 at 84.0 seconds of observation.
Headway: 1371
Vehicle Release: 59 at 85.0 seconds of observation.
Headway: 1988
Vehicle Release: 60 at 87.0 seconds of observation.
Headway: 1497
Vehicle Release: 61 at 89.0 seconds of observation.
Headway: 1696
Vehicle Release: 62 at 90.0 seconds of observation.
Headway: 1312
Vehicle Release: 63 at 92.0 seconds of observation.
Headway: 1112
Vehicle Release: 64 at 93.0 seconds of observation.
Headway: 1022
Vehicle Release: 65 at 94.0 seconds of observation.
Headway: 1181
Vehicle Release: 66 at 95.0 seconds of observation.
Headway: 1087
Vehicle Release: 67 at 96.0 seconds of observation.
Headway: 1386
Vehicle Release: 68 at 98.0 seconds of observation.
Headway: 1840
Vehicle Release: 69 at 99.0 seconds of observation.
Headway: 1114
Vehicle Release: 70 at 101.0 seconds of observation.
Headway: 1986
Vehicle Release: 71 at 103.0 seconds of observation.
Headway: 1935
Vehicle Release: 72 at 104.0 seconds of observation.
Headway: 1386
Vehicle Release: 73 at 106.0 seconds of observation.
Headway: 1231
Vehicle Release: 74 at 107.0 seconds of observation.

Headway: 1885
Vehicle Release: 75 at 109.0 seconds of observation.
Headway: 1658
Vehicle Release: 76 at 111.0 seconds of observation.
Headway: 1197
Vehicle Release: 77 at 112.0 seconds of observation.
Headway: 1988
Vehicle Release: 78 at 114.0 seconds of observation.
Headway: 1025
Vehicle Release: 79 at 115.0 seconds of observation.
Headway: 1101
Vehicle Release: 80 at 116.0 seconds of observation.
Headway: 1214
Vehicle Release: 81 at 117.0 seconds of observation.
Headway: 1490
Vehicle Release: 82 at 119.0 seconds of observation.
Headway: 1444
Vehicle Release: 83 at 120.0 seconds of observation.
Headway: 1676
Vehicle Release: 84 at 122.0 seconds of observation.
Headway: 1936
Vehicle Release: 85 at 124.0 seconds of observation.
Headway: 1444
Vehicle Release: 86 at 125.0 seconds of observation.
Headway: 1532
Vehicle Release: 87 at 127.0 seconds of observation.
Headway: 1856
Vehicle Release: 88 at 129.0 seconds of observation.
Headway: 1469
Vehicle Release: 89 at 130.0 seconds of observation.
Headway: 1824
Vehicle Release: 90 at 132.0 seconds of observation.
Headway: 1527
Vehicle Release: 91 at 134.0 seconds of observation.
Headway: 1270
Vehicle Release: 92 at 135.0 seconds of observation.
Headway: 1963
Vehicle Release: 93 at 137.0 seconds of observation.
Headway: 1899
Vehicle Release: 94 at 139.0 seconds of observation.
Headway: 1903
Vehicle Release: 95 at 141.0 seconds of observation.
Headway: 1224
Vehicle Release: 96 at 142.0 seconds of observation.
Headway: 1215
Vehicle Release: 97 at 143.0 seconds of observation.
Headway: 1239
Vehicle Release: 98 at 144.0 seconds of observation.
Headway: 1179
Vehicle Release: 99 at 146.0 seconds of observation.

Headway: 1011
Vehicle Release: 100 at 147.0 seconds of observation.
Headway: 1903
Vehicle Release: 101 at 149.0 seconds of observation.
Headway: 1163
Vehicle Release: 102 at 150.0 seconds of observation.
Headway: 1544
Vehicle Release: 103 at 151.0 seconds of observation.
Headway: 1407
Vehicle Release: 104 at 153.0 seconds of observation.
Headway: 1367
Vehicle Release: 105 at 154.0 seconds of observation.
Headway: 1903
Vehicle Release: 106 at 156.0 seconds of observation.
Headway: 1236
Vehicle Release: 107 at 157.0 seconds of observation.
Headway: 1476
Vehicle Release: 108 at 159.0 seconds of observation.
Headway: 1824
Vehicle Release: 109 at 161.0 seconds of observation.
Headway: 1035
Vehicle Release: 110 at 162.0 seconds of observation.
Headway: 1559
Vehicle Release: 111 at 163.0 seconds of observation.
Headway: 1662
Vehicle Release: 112 at 165.0 seconds of observation.
Headway: 1004
Vehicle Release: 113 at 166.0 seconds of observation.
Headway: 1857
Vehicle Release: 114 at 168.0 seconds of observation.
Headway: 1481
Vehicle Release: 115 at 169.0 seconds of observation.
Headway: 1333
Vehicle Release: 116 at 171.0 seconds of observation.
Headway: 1662
Vehicle Release: 117 at 172.0 seconds of observation.
Headway: 1818
Vehicle Release: 118 at 174.0 seconds of observation.
Headway: 1354
Vehicle Release: 119 at 176.0 seconds of observation.
Headway: 1213
Vehicle Release: 120 at 177.0 seconds of observation.
Headway: 1529
Vehicle Release: 121 at 178.0 seconds of observation.
Headway: 1986
Vehicle Release: 122 at 180.0 seconds of observation.
Headway: 1914
Vehicle Release: 123 at 182.0 seconds of observation.
Headway: 1361
Vehicle Release: 124 at 184.0 seconds of observation.

Headway: 1198
Vehicle Release: 125 at 185.0 seconds of observation.
Headway: 1750
Vehicle Release: 126 at 187.0 seconds of observation.
Headway: 1535
Vehicle Release: 127 at 188.0 seconds of observation.
Headway: 1021
Vehicle Release: 128 at 189.0 seconds of observation.
Headway: 1152
Vehicle Release: 129 at 190.0 seconds of observation.
Headway: 1175
Vehicle Release: 130 at 192.0 seconds of observation.
Headway: 1842
Vehicle Release: 131 at 193.0 seconds of observation.
Headway: 1126
Vehicle Release: 132 at 195.0 seconds of observation.
Headway: 1635
Vehicle Release: 133 at 196.0 seconds of observation.
Headway: 1203
Vehicle Release: 134 at 197.0 seconds of observation.
Headway: 1803
Vehicle Release: 135 at 199.0 seconds of observation.
Headway: 1022
Vehicle Release: 136 at 200.0 seconds of observation.
Headway: 1115
Vehicle Release: 137 at 201.0 seconds of observation.
Headway: 1420
Vehicle Release: 138 at 203.0 seconds of observation.
Headway: 1280
Vehicle Release: 139 at 204.0 seconds of observation.
Headway: 1289
Vehicle Release: 140 at 205.0 seconds of observation.
Headway: 1240
Vehicle Release: 141 at 207.0 seconds of observation.
Headway: 1235
Vehicle Release: 142 at 208.0 seconds of observation.
Headway: 1284
Vehicle Release: 143 at 209.0 seconds of observation.
Headway: 1471
Vehicle Release: 144 at 211.0 seconds of observation.
Headway: 1992
Vehicle Release: 145 at 213.0 seconds of observation.
Headway: 1607
Vehicle Release: 146 at 214.0 seconds of observation.
Headway: 1541
Vehicle Release: 147 at 216.0 seconds of observation.
Headway: 1488
Vehicle Release: 148 at 217.0 seconds of observation.
Headway: 1971
Vehicle Release: 149 at 219.0 seconds of observation.

Headway: 1638
Vehicle Release: 150 at 221.0 seconds of observation.
Headway: 1811
Vehicle Release: 151 at 223.0 seconds of observation.
Headway: 1545
Vehicle Release: 152 at 224.0 seconds of observation.
Headway: 1707
Vehicle Release: 153 at 226.0 seconds of observation.
Headway: 1451
Vehicle Release: 154 at 228.0 seconds of observation.
Headway: 1279
Vehicle Release: 155 at 229.0 seconds of observation.
Headway: 1606
Vehicle Release: 156 at 230.0 seconds of observation.
Headway: 1978
Vehicle Release: 157 at 232.0 seconds of observation.
Headway: 1609
Vehicle Release: 158 at 234.0 seconds of observation.
Headway: 1745
Vehicle Release: 159 at 236.0 seconds of observation.
Headway: 1752
Vehicle Release: 160 at 238.0 seconds of observation.
Headway: 1602
Vehicle Release: 161 at 239.0 seconds of observation.
Headway: 1530
Vehicle Release: 162 at 241.0 seconds of observation.
Headway: 1918
Vehicle Release: 163 at 243.0 seconds of observation.
Headway: 1151
Vehicle Release: 164 at 244.0 seconds of observation.
Headway: 1770
Vehicle Release: 165 at 246.0 seconds of observation.
Headway: 1392
Vehicle Release: 166 at 247.0 seconds of observation.
Headway: 1999
Vehicle Release: 167 at 249.0 seconds of observation.
Headway: 1388
Vehicle Release: 168 at 250.0 seconds of observation.
Headway: 1595
Vehicle Release: 169 at 252.0 seconds of observation.
Headway: 1683
Vehicle Release: 170 at 254.0 seconds of observation.
Headway: 1802
Vehicle Release: 171 at 256.0 seconds of observation.
Headway: 1377
Vehicle Release: 172 at 257.0 seconds of observation.
Headway: 1209
Vehicle Release: 173 at 258.0 seconds of observation.
Headway: 1954
Vehicle Release: 174 at 260.0 seconds of observation.

Headway: 1374
Vehicle Release: 175 at 261.0 seconds of observation.
Headway: 1497
Vehicle Release: 176 at 263.0 seconds of observation.
Headway: 1418
Vehicle Release: 177 at 264.0 seconds of observation.
Headway: 1105
Vehicle Release: 178 at 266.0 seconds of observation.
Headway: 1527
Vehicle Release: 179 at 267.0 seconds of observation.
Headway: 1449
Vehicle Release: 180 at 269.0 seconds of observation.
Headway: 1164
Vehicle Release: 181 at 270.0 seconds of observation.
Headway: 1817
Vehicle Release: 182 at 272.0 seconds of observation.
Headway: 1707
Vehicle Release: 183 at 273.0 seconds of observation.
Headway: 1695
Vehicle Release: 184 at 275.0 seconds of observation.
Headway: 1575
Vehicle Release: 185 at 277.0 seconds of observation.
Headway: 1588
Vehicle Release: 186 at 278.0 seconds of observation.
Headway: 1012
Vehicle Release: 187 at 279.0 seconds of observation.
Headway: 1588
Vehicle Release: 188 at 281.0 seconds of observation.
Headway: 1922
Vehicle Release: 189 at 283.0 seconds of observation.
Headway: 1276
Vehicle Release: 190 at 284.0 seconds of observation.
Headway: 1983
Vehicle Release: 191 at 286.0 seconds of observation.
Headway: 1379
Vehicle Release: 192 at 287.0 seconds of observation.
Headway: 1480
Vehicle Release: 193 at 289.0 seconds of observation.
Headway: 1324
Vehicle Release: 194 at 290.0 seconds of observation.
Headway: 1377
Vehicle Release: 195 at 292.0 seconds of observation.
Headway: 1881
Vehicle Release: 196 at 293.0 seconds of observation.
Headway: 1488
Vehicle Release: 197 at 295.0 seconds of observation.
Headway: 1454
Vehicle Release: 198 at 296.0 seconds of observation.
Headway: 1071
Vehicle Release: 199 at 298.0 seconds of observation.

Headway: 1312
Vehicle Release: 200 at 299.0 seconds of observation.
Headway: 1008
Vehicle Release: 201 at 300.0 seconds of observation.
Headway: 1357
Vehicle Release: 202 at 301.0 seconds of observation.
Headway: 1201
Vehicle Release: 203 at 302.0 seconds of observation.
Headway: 1510
Vehicle Release: 204 at 304.0 seconds of observation.
Headway: 1166
Vehicle Release: 205 at 305.0 seconds of observation.
Headway: 1840
Vehicle Release: 206 at 307.0 seconds of observation.
Headway: 1361
Vehicle Release: 207 at 308.0 seconds of observation.
Headway: 1952
Vehicle Release: 208 at 310.0 seconds of observation.
Headway: 1208
Vehicle Release: 209 at 311.0 seconds of observation.
Headway: 1577
Vehicle Release: 210 at 313.0 seconds of observation.
Headway: 1885
Vehicle Release: 211 at 315.0 seconds of observation.
Headway: 1157
Vehicle Release: 212 at 316.0 seconds of observation.
Headway: 1780
Vehicle Release: 213 at 318.0 seconds of observation.
Headway: 1708
Vehicle Release: 214 at 320.0 seconds of observation.
Headway: 1250
Vehicle Release: 215 at 321.0 seconds of observation.
Headway: 1735
Vehicle Release: 216 at 323.0 seconds of observation.
Headway: 1622
Vehicle Release: 217 at 324.0 seconds of observation.
Headway: 1454
Vehicle Release: 218 at 326.0 seconds of observation.
Headway: 1375
Vehicle Release: 219 at 327.0 seconds of observation.
Headway: 1884
Vehicle Release: 220 at 329.0 seconds of observation.
Headway: 1087
Vehicle Release: 221 at 330.0 seconds of observation.
Headway: 1623
Vehicle Release: 222 at 332.0 seconds of observation.
Headway: 1092
Vehicle Release: 223 at 333.0 seconds of observation.
Headway: 1677
Vehicle Release: 224 at 335.0 seconds of observation.

Headway: 1094
Vehicle Release: 225 at 336.0 seconds of observation.
Headway: 1031
Vehicle Release: 226 at 337.0 seconds of observation.
Headway: 1064
Vehicle Release: 227 at 338.0 seconds of observation.
Headway: 1695
Vehicle Release: 228 at 339.0 seconds of observation.
Headway: 1324
Vehicle Release: 229 at 341.0 seconds of observation.
Headway: 1034
Vehicle Release: 230 at 342.0 seconds of observation.
Headway: 1356
Vehicle Release: 231 at 343.0 seconds of observation.
Headway: 1942
Vehicle Release: 232 at 345.0 seconds of observation.
Headway: 1630
Vehicle Release: 233 at 347.0 seconds of observation.
Headway: 1372
Vehicle Release: 234 at 348.0 seconds of observation.
Headway: 1419
Vehicle Release: 235 at 350.0 seconds of observation.
Headway: 1707
Vehicle Release: 236 at 351.0 seconds of observation.
Headway: 1058
Vehicle Release: 237 at 352.0 seconds of observation.
Headway: 1954
Vehicle Release: 238 at 354.0 seconds of observation.
Headway: 1997
Vehicle Release: 239 at 356.0 seconds of observation.
Headway: 1006
Vehicle Release: 240 at 357.0 seconds of observation.
Headway: 1320
Vehicle Release: 241 at 359.0 seconds of observation.
Headway: 1749
Vehicle Release: 242 at 360.0 seconds of observation.
Headway: 1094
Vehicle Release: 243 at 362.0 seconds of observation.
Headway: 1025
Vehicle Release: 244 at 363.0 seconds of observation.
Headway: 1962
Vehicle Release: 245 at 365.0 seconds of observation.
Headway: 1133
Vehicle Release: 246 at 366.0 seconds of observation.
Headway: 1599
Vehicle Release: 247 at 367.0 seconds of observation.
Headway: 1005
Vehicle Release: 248 at 368.0 seconds of observation.
Headway: 1531
Vehicle Release: 249 at 372.0 seconds of observation.

Headway: 1440
Vehicle Release: 250 at 373.0 seconds of observation.
Headway: 1866
Vehicle Release: 251 at 375.0 seconds of observation.
Headway: 1881
Vehicle Release: 252 at 377.0 seconds of observation.
Headway: 1640
Vehicle Release: 253 at 379.0 seconds of observation.
Headway: 1211
Vehicle Release: 254 at 380.0 seconds of observation.
Headway: 1795
Vehicle Release: 255 at 382.0 seconds of observation.
Headway: 1085
Vehicle Release: 256 at 383.0 seconds of observation.
Headway: 1860
Vehicle Release: 257 at 385.0 seconds of observation.
Headway: 1445
Vehicle Release: 258 at 386.0 seconds of observation.
Headway: 1236
Vehicle Release: 259 at 387.0 seconds of observation.
Headway: 1208
Vehicle Release: 260 at 389.0 seconds of observation.
Headway: 1741
Vehicle Release: 261 at 390.0 seconds of observation.
Headway: 1514
Vehicle Release: 262 at 392.0 seconds of observation.
Headway: 1175
Vehicle Release: 263 at 393.0 seconds of observation.
Headway: 1468
Vehicle Release: 264 at 395.0 seconds of observation.
Headway: 1867
Vehicle Release: 265 at 396.0 seconds of observation.
Headway: 1531
Vehicle Release: 266 at 398.0 seconds of observation.
Headway: 1021
Vehicle Release: 267 at 399.0 seconds of observation.
Headway: 1734
Vehicle Release: 268 at 401.0 seconds of observation.
Headway: 1144
Vehicle Release: 269 at 402.0 seconds of observation.
Headway: 1772
Vehicle Release: 270 at 404.0 seconds of observation.
Headway: 1992
Vehicle Release: 271 at 406.0 seconds of observation.
Headway: 1264
Vehicle Release: 272 at 407.0 seconds of observation.
Headway: 1592
Vehicle Release: 273 at 409.0 seconds of observation.
Headway: 1601
Vehicle Release: 274 at 410.0 seconds of observation.

Headway: 1082
Vehicle Release: 275 at 411.0 seconds of observation.
Headway: 1170
Vehicle Release: 276 at 412.0 seconds of observation.
Headway: 1233
Vehicle Release: 277 at 414.0 seconds of observation.
Headway: 1897
Vehicle Release: 278 at 416.0 seconds of observation.
Headway: 1412
Vehicle Release: 279 at 417.0 seconds of observation.
Headway: 1043
Vehicle Release: 280 at 418.0 seconds of observation.
Headway: 1617
Vehicle Release: 281 at 420.0 seconds of observation.
Headway: 1765
Vehicle Release: 282 at 422.0 seconds of observation.
Headway: 1074
Vehicle Release: 283 at 423.0 seconds of observation.
Headway: 1404
Vehicle Release: 284 at 424.0 seconds of observation.
Headway: 1935
Vehicle Release: 285 at 426.0 seconds of observation.
Headway: 1105
Vehicle Release: 286 at 427.0 seconds of observation.
Headway: 1098
Vehicle Release: 287 at 428.0 seconds of observation.
Headway: 1440
Vehicle Release: 288 at 430.0 seconds of observation.
Headway: 1539
Vehicle Release: 289 at 431.0 seconds of observation.
Headway: 1063
Vehicle Release: 290 at 432.0 seconds of observation.
Headway: 1798
Vehicle Release: 291 at 434.0 seconds of observation.
Headway: 1777
Vehicle Release: 292 at 436.0 seconds of observation.
Headway: 1399
Vehicle Release: 293 at 437.0 seconds of observation.
Headway: 1929
Vehicle Release: 294 at 439.0 seconds of observation.
Headway: 1478
Vehicle Release: 295 at 441.0 seconds of observation.
Headway: 1739
Vehicle Release: 296 at 443.0 seconds of observation.
Headway: 1528
Vehicle Release: 297 at 444.0 seconds of observation.
Headway: 1757
Vehicle Release: 298 at 446.0 seconds of observation.
Headway: 1801
Vehicle Release: 299 at 448.0 seconds of observation.

Headway: 1985
Vehicle Release: 300 at 450.0 seconds of observation.
Headway: 1425
Vehicle Release: 301 at 451.0 seconds of observation.
Headway: 1935
Vehicle Release: 302 at 453.0 seconds of observation.
Headway: 1215
Vehicle Release: 303 at 454.0 seconds of observation.
Headway: 1361
Vehicle Release: 304 at 456.0 seconds of observation.
Headway: 1652
Vehicle Release: 305 at 457.0 seconds of observation.
Headway: 1140
Vehicle Release: 306 at 459.0 seconds of observation.
Headway: 1153
Vehicle Release: 307 at 460.0 seconds of observation.
Headway: 1900
Vehicle Release: 308 at 462.0 seconds of observation.
Headway: 1362
Vehicle Release: 309 at 463.0 seconds of observation.
Headway: 1231
Vehicle Release: 310 at 464.0 seconds of observation.
Headway: 1429
Vehicle Release: 311 at 466.0 seconds of observation.
Headway: 1637
Vehicle Release: 312 at 467.0 seconds of observation.
Headway: 1870
Vehicle Release: 313 at 469.0 seconds of observation.
Headway: 1240
Vehicle Release: 314 at 470.0 seconds of observation.
Headway: 1240
Vehicle Release: 315 at 472.0 seconds of observation.
Headway: 1191
Vehicle Release: 316 at 473.0 seconds of observation.
Headway: 1978
Vehicle Release: 317 at 475.0 seconds of observation.
Headway: 1122
Vehicle Release: 318 at 476.0 seconds of observation.
Headway: 1709
Vehicle Release: 319 at 478.0 seconds of observation.
Headway: 1664
Vehicle Release: 320 at 479.0 seconds of observation.
Headway: 1770
Vehicle Release: 321 at 481.0 seconds of observation.
Headway: 1159
Vehicle Release: 322 at 482.0 seconds of observation.
Headway: 1547
Vehicle Release: 323 at 484.0 seconds of observation.
Headway: 1611
Vehicle Release: 324 at 486.0 seconds of observation.

Headway: 1048
Vehicle Release: 325 at 487.0 seconds of observation.
Headway: 1268
Vehicle Release: 326 at 488.0 seconds of observation.
Headway: 1686
Vehicle Release: 327 at 490.0 seconds of observation.
Headway: 1809
Vehicle Release: 328 at 492.0 seconds of observation.
Headway: 1075
Vehicle Release: 329 at 493.0 seconds of observation.
Headway: 1880
Vehicle Release: 330 at 494.0 seconds of observation.
Headway: 1068
Vehicle Release: 331 at 496.0 seconds of observation.
Headway: 1949
Vehicle Release: 332 at 498.0 seconds of observation.
Headway: 1162
Vehicle Release: 333 at 499.0 seconds of observation.
Headway: 1820
Vehicle Release: 334 at 501.0 seconds of observation.
Headway: 1312
Vehicle Release: 335 at 502.0 seconds of observation.
Headway: 1197
Vehicle Release: 336 at 503.0 seconds of observation.
Headway: 1796
Vehicle Release: 337 at 505.0 seconds of observation.
Headway: 1777
Vehicle Release: 338 at 507.0 seconds of observation.
Headway: 1282
Vehicle Release: 339 at 508.0 seconds of observation.
Headway: 1053
Vehicle Release: 340 at 509.0 seconds of observation.
Headway: 1656
Vehicle Release: 341 at 511.0 seconds of observation.
Headway: 1719
Vehicle Release: 342 at 513.0 seconds of observation.
Headway: 1822
Vehicle Release: 343 at 514.0 seconds of observation.
Headway: 1725
Vehicle Release: 344 at 516.0 seconds of observation.
Headway: 1359
Vehicle Release: 345 at 518.0 seconds of observation.
Headway: 1757
Vehicle Release: 346 at 519.0 seconds of observation.
Headway: 1839
Vehicle Release: 347 at 521.0 seconds of observation.
Headway: 1039
Vehicle Release: 348 at 522.0 seconds of observation.
Headway: 1931
Vehicle Release: 349 at 524.0 seconds of observation.

Headway: 1926
Vehicle Release: 350 at 526.0 seconds of observation.
Headway: 1439
Vehicle Release: 351 at 528.0 seconds of observation.
Headway: 1228
Vehicle Release: 352 at 529.0 seconds of observation.
Headway: 1787
Vehicle Release: 353 at 531.0 seconds of observation.
Headway: 1954
Vehicle Release: 354 at 533.0 seconds of observation.
Headway: 1541
Vehicle Release: 355 at 534.0 seconds of observation.
Headway: 1463
Vehicle Release: 356 at 536.0 seconds of observation.
Headway: 1679
Vehicle Release: 357 at 537.0 seconds of observation.
Headway: 1234
Vehicle Release: 358 at 538.0 seconds of observation.
Headway: 1782
Vehicle Release: 359 at 540.0 seconds of observation.
Headway: 1094
Vehicle Release: 360 at 541.0 seconds of observation.
Headway: 1868
Vehicle Release: 361 at 543.0 seconds of observation.
Headway: 1330
Vehicle Release: 362 at 545.0 seconds of observation.
Headway: 1367
Vehicle Release: 363 at 546.0 seconds of observation.
Headway: 1901
Vehicle Release: 364 at 548.0 seconds of observation.
Headway: 1756
Vehicle Release: 365 at 550.0 seconds of observation.
Headway: 1223
Vehicle Release: 366 at 551.0 seconds of observation.
Headway: 1379
Vehicle Release: 367 at 552.0 seconds of observation.
Headway: 1937
Vehicle Release: 368 at 554.0 seconds of observation.
Headway: 1049
Vehicle Release: 369 at 555.0 seconds of observation.
Headway: 1250
Vehicle Release: 370 at 557.0 seconds of observation.
Headway: 1091
Vehicle Release: 371 at 558.0 seconds of observation.
Headway: 1055
Vehicle Release: 372 at 559.0 seconds of observation.
Headway: 1753
Vehicle Release: 373 at 560.0 seconds of observation.
Headway: 1235
Vehicle Release: 374 at 562.0 seconds of observation.

Headway: 1519
Vehicle Release: 375 at 563.0 seconds of observation.
Headway: 1406
Vehicle Release: 376 at 565.0 seconds of observation.
Headway: 1836
Vehicle Release: 377 at 567.0 seconds of observation.
Headway: 1065
Vehicle Release: 378 at 568.0 seconds of observation.
Headway: 1005
Vehicle Release: 379 at 569.0 seconds of observation.
Headway: 1529
Vehicle Release: 380 at 570.0 seconds of observation.
Headway: 1061
Vehicle Release: 381 at 571.0 seconds of observation.
Headway: 1820
Vehicle Release: 382 at 573.0 seconds of observation.
Headway: 1084
Vehicle Release: 383 at 574.0 seconds of observation.
Headway: 1209
Vehicle Release: 384 at 575.0 seconds of observation.
Headway: 1468
Vehicle Release: 385 at 577.0 seconds of observation.
Headway: 1557
Vehicle Release: 386 at 578.0 seconds of observation.
Headway: 1710
Vehicle Release: 387 at 580.0 seconds of observation.
Headway: 1009
Vehicle Release: 388 at 581.0 seconds of observation.
Headway: 1546
Vehicle Release: 389 at 583.0 seconds of observation.
Headway: 1077
Vehicle Release: 390 at 584.0 seconds of observation.
Headway: 1472
Vehicle Release: 391 at 585.0 seconds of observation.
Headway: 1878
Vehicle Release: 392 at 587.0 seconds of observation.
Headway: 1176
Vehicle Release: 393 at 588.0 seconds of observation.
Headway: 1021
Vehicle Release: 394 at 589.0 seconds of observation.
Headway: 1759
Vehicle Release: 395 at 591.0 seconds of observation.
Headway: 1441
Vehicle Release: 396 at 593.0 seconds of observation.
Headway: 1793
Vehicle Release: 397 at 594.0 seconds of observation.
Headway: 1659
Vehicle Release: 398 at 596.0 seconds of observation.
Headway: 1456
Vehicle Release: 399 at 598.0 seconds of observation.

Headway: 1228
Vehicle Release: 400 at 599.0 seconds of observation.
Headway: 1356
Vehicle Release: 401 at 600.0 seconds of observation.
Headway: 1793
Vehicle Release: 402 at 602.0 seconds of observation.
Headway: 1550
Vehicle Release: 403 at 604.0 seconds of observation.
Headway: 1600
Vehicle Release: 404 at 605.0 seconds of observation.
Headway: 1413
Vehicle Release: 405 at 607.0 seconds of observation.
Headway: 1313
Vehicle Release: 406 at 608.0 seconds of observation.
Headway: 1704
Vehicle Release: 407 at 610.0 seconds of observation.
Headway: 1279
Vehicle Release: 408 at 611.0 seconds of observation.
Headway: 1046
Vehicle Release: 409 at 612.0 seconds of observation.
Headway: 1972
Vehicle Release: 410 at 614.0 seconds of observation.
Headway: 1255
Vehicle Release: 411 at 615.0 seconds of observation.
Headway: 1233
Vehicle Release: 412 at 616.0 seconds of observation.
Headway: 1657
Vehicle Release: 413 at 618.0 seconds of observation.
Headway: 1747
Vehicle Release: 414 at 620.0 seconds of observation.
Headway: 1341
Vehicle Release: 415 at 621.0 seconds of observation.
Headway: 1119
Vehicle Release: 416 at 622.0 seconds of observation.
Headway: 1061
Vehicle Release: 417 at 623.0 seconds of observation.
Headway: 1757
Vehicle Release: 418 at 625.0 seconds of observation.
Headway: 1082
Vehicle Release: 419 at 626.0 seconds of observation.
Headway: 1075
Vehicle Release: 420 at 627.0 seconds of observation.
Headway: 1189
Vehicle Release: 421 at 629.0 seconds of observation.
Headway: 1790
Vehicle Release: 422 at 630.0 seconds of observation.
Headway: 1311
Vehicle Release: 423 at 632.0 seconds of observation.
Headway: 1459
Vehicle Release: 424 at 633.0 seconds of observation.

Headway: 1893
Vehicle Release: 425 at 637.0 seconds of observation.
Headway: 1914
Vehicle Release: 426 at 639.0 seconds of observation.
Headway: 1106
Vehicle Release: 427 at 640.0 seconds of observation.
Headway: 1021
Vehicle Release: 428 at 641.0 seconds of observation.
Headway: 1550
Vehicle Release: 429 at 642.0 seconds of observation.
Headway: 1429
Vehicle Release: 430 at 644.0 seconds of observation.
Headway: 1320
Vehicle Release: 431 at 645.0 seconds of observation.
Headway: 1709
Vehicle Release: 432 at 647.0 seconds of observation.
Headway: 1548
Vehicle Release: 433 at 648.0 seconds of observation.
Headway: 1956
Vehicle Release: 434 at 650.0 seconds of observation.
Headway: 1891
Vehicle Release: 435 at 652.0 seconds of observation.
Headway: 1529
Vehicle Release: 436 at 654.0 seconds of observation.
Headway: 1088
Vehicle Release: 437 at 655.0 seconds of observation.
Headway: 1092
Vehicle Release: 438 at 656.0 seconds of observation.
Headway: 1088
Vehicle Release: 439 at 657.0 seconds of observation.
Headway: 1767
Vehicle Release: 440 at 659.0 seconds of observation.
Headway: 1089
Vehicle Release: 441 at 660.0 seconds of observation.
Headway: 1288
Vehicle Release: 442 at 661.0 seconds of observation.
Headway: 1058
Vehicle Release: 443 at 662.0 seconds of observation.
Headway: 1084
Vehicle Release: 444 at 664.0 seconds of observation.
Headway: 1456
Vehicle Release: 445 at 665.0 seconds of observation.
Headway: 1066
Vehicle Release: 446 at 666.0 seconds of observation.
Headway: 1450
Vehicle Release: 447 at 668.0 seconds of observation.
Headway: 1515
Vehicle Release: 448 at 669.0 seconds of observation.
Headway: 1459
Vehicle Release: 449 at 671.0 seconds of observation.

Headway: 1765
Vehicle Release: 450 at 672.0 seconds of observation.
Headway: 1736
Vehicle Release: 451 at 674.0 seconds of observation.
Headway: 1422
Vehicle Release: 452 at 675.0 seconds of observation.
Headway: 1633
Vehicle Release: 453 at 677.0 seconds of observation.
Headway: 1475
Vehicle Release: 454 at 679.0 seconds of observation.
Headway: 1582
Vehicle Release: 455 at 680.0 seconds of observation.
Headway: 1094
Vehicle Release: 456 at 681.0 seconds of observation.
Headway: 1024
Vehicle Release: 457 at 682.0 seconds of observation.
Headway: 1202
Vehicle Release: 458 at 684.0 seconds of observation.
Headway: 1865
Vehicle Release: 459 at 685.0 seconds of observation.
Headway: 1680
Vehicle Release: 460 at 687.0 seconds of observation.
Headway: 1221
Vehicle Release: 461 at 688.0 seconds of observation.
Headway: 1401
Vehicle Release: 462 at 690.0 seconds of observation.
Headway: 1833
Vehicle Release: 463 at 692.0 seconds of observation.
Headway: 1014
Vehicle Release: 464 at 693.0 seconds of observation.
Headway: 1339
Vehicle Release: 465 at 694.0 seconds of observation.
Headway: 1844
Vehicle Release: 466 at 696.0 seconds of observation.
Headway: 1819
Vehicle Release: 467 at 698.0 seconds of observation.
Headway: 1386
Vehicle Release: 468 at 699.0 seconds of observation.
Headway: 1761
Vehicle Release: 469 at 701.0 seconds of observation.
Headway: 1276
Vehicle Release: 470 at 702.0 seconds of observation.
Headway: 1312
Vehicle Release: 471 at 703.0 seconds of observation.
Headway: 1635
Vehicle Release: 472 at 705.0 seconds of observation.
Headway: 1825
Vehicle Release: 473 at 707.0 seconds of observation.
Headway: 1701
Vehicle Release: 474 at 709.0 seconds of observation.

Headway: 1004
Vehicle Release: 475 at 710.0 seconds of observation.
Headway: 1481
Vehicle Release: 476 at 711.0 seconds of observation.
Headway: 1897
Vehicle Release: 477 at 713.0 seconds of observation.
Headway: 1235
Vehicle Release: 478 at 714.0 seconds of observation.
Headway: 1938
Vehicle Release: 479 at 716.0 seconds of observation.
Headway: 1292
Vehicle Release: 480 at 718.0 seconds of observation.
Headway: 1121
Vehicle Release: 481 at 719.0 seconds of observation.
Headway: 1071
Vehicle Release: 482 at 720.0 seconds of observation.
Headway: 1376
Vehicle Release: 483 at 726.0 seconds of observation.
Headway: 1045
Vehicle Release: 484 at 727.0 seconds of observation.
Headway: 1779
Vehicle Release: 485 at 729.0 seconds of observation.
Headway: 1719
Vehicle Release: 486 at 730.0 seconds of observation.
Headway: 1623
Vehicle Release: 487 at 732.0 seconds of observation.
Headway: 1289
Vehicle Release: 488 at 733.0 seconds of observation.
Headway: 1232
Vehicle Release: 489 at 735.0 seconds of observation.
Headway: 1516
Vehicle Release: 490 at 736.0 seconds of observation.
Headway: 1462
Vehicle Release: 491 at 742.0 seconds of observation.
Headway: 1057
Vehicle Release: 492 at 743.0 seconds of observation.
Headway: 1144
Vehicle Release: 493 at 744.0 seconds of observation.
Headway: 1220
Vehicle Release: 494 at 745.0 seconds of observation.
Headway: 1081
Vehicle Release: 495 at 746.0 seconds of observation.
Headway: 1001
Vehicle Release: 496 at 747.0 seconds of observation.
Headway: 1395
Vehicle Release: 497 at 749.0 seconds of observation.
Headway: 1082
Vehicle Release: 498 at 750.0 seconds of observation.
Headway: 1226
Vehicle Release: 499 at 751.0 seconds of observation.

Headway: 1314
Vehicle Release: 500 at 753.0 seconds of observation.
Headway: 1916
Vehicle Release: 501 at 755.0 seconds of observation.
Headway: 1983
Vehicle Release: 502 at 757.0 seconds of observation.
Headway: 1009
Vehicle Release: 503 at 758.0 seconds of observation.
Headway: 1036
Vehicle Release: 504 at 759.0 seconds of observation.
Headway: 1987
Vehicle Release: 505 at 761.0 seconds of observation.
Headway: 1401
Vehicle Release: 506 at 763.0 seconds of observation.
Headway: 1285
Vehicle Release: 507 at 764.0 seconds of observation.
Headway: 1688
Vehicle Release: 508 at 766.0 seconds of observation.
Headway: 1850
Vehicle Release: 509 at 767.0 seconds of observation.
Headway: 1212
Vehicle Release: 510 at 769.0 seconds of observation.
Headway: 1535
Vehicle Release: 511 at 770.0 seconds of observation.
Headway: 1728
Vehicle Release: 512 at 772.0 seconds of observation.
Headway: 1435
Vehicle Release: 513 at 773.0 seconds of observation.
Headway: 1408
Vehicle Release: 514 at 775.0 seconds of observation.
Headway: 1080
Vehicle Release: 515 at 776.0 seconds of observation.
Headway: 1971
Vehicle Release: 516 at 778.0 seconds of observation.
Headway: 1558
Vehicle Release: 517 at 779.0 seconds of observation.
Headway: 1814
Vehicle Release: 518 at 781.0 seconds of observation.
Headway: 1832
Vehicle Release: 519 at 783.0 seconds of observation.
Headway: 1351
Vehicle Release: 520 at 784.0 seconds of observation.
Headway: 1396
Vehicle Release: 521 at 786.0 seconds of observation.
Headway: 1673
Vehicle Release: 522 at 788.0 seconds of observation.
Headway: 1998
Vehicle Release: 523 at 790.0 seconds of observation.
Headway: 1791
Vehicle Release: 524 at 791.0 seconds of observation.

Headway: 1327
Vehicle Release: 525 at 793.0 seconds of observation.
Headway: 1930
Vehicle Release: 526 at 795.0 seconds of observation.
Headway: 1072
Vehicle Release: 527 at 796.0 seconds of observation.
Headway: 1935
Vehicle Release: 528 at 798.0 seconds of observation.
Headway: 1515
Vehicle Release: 529 at 799.0 seconds of observation.
Headway: 1817
Vehicle Release: 530 at 801.0 seconds of observation.
Headway: 1126
Vehicle Release: 531 at 802.0 seconds of observation.
Headway: 1383
Vehicle Release: 532 at 804.0 seconds of observation.
Headway: 1041
Vehicle Release: 533 at 805.0 seconds of observation.
Headway: 1010
Vehicle Release: 534 at 806.0 seconds of observation.
Headway: 1980
Vehicle Release: 535 at 808.0 seconds of observation.
Headway: 1874
Vehicle Release: 536 at 810.0 seconds of observation.
Headway: 1510
Vehicle Release: 537 at 811.0 seconds of observation.
Headway: 1027
Vehicle Release: 538 at 812.0 seconds of observation.
Headway: 1656
Vehicle Release: 539 at 814.0 seconds of observation.
Headway: 1941
Vehicle Release: 540 at 816.0 seconds of observation.
Headway: 1314
Vehicle Release: 541 at 817.0 seconds of observation.
Headway: 1068
Vehicle Release: 542 at 818.0 seconds of observation.
Headway: 1533
Vehicle Release: 543 at 820.0 seconds of observation.
Headway: 1592
Vehicle Release: 544 at 821.0 seconds of observation.
Headway: 1792
Vehicle Release: 545 at 823.0 seconds of observation.
Headway: 1465
Vehicle Release: 546 at 825.0 seconds of observation.
Headway: 1324
Vehicle Release: 547 at 826.0 seconds of observation.
Headway: 1146
Vehicle Release: 548 at 827.0 seconds of observation.
Headway: 1568
Vehicle Release: 549 at 829.0 seconds of observation.

Headway: 1306
Vehicle Release: 550 at 830.0 seconds of observation.
Headway: 1930
Vehicle Release: 551 at 832.0 seconds of observation.
Headway: 1103
Vehicle Release: 552 at 834.0 seconds of observation.
Headway: 1604
Vehicle Release: 553 at 835.0 seconds of observation.
Headway: 1167
Vehicle Release: 554 at 836.0 seconds of observation.
Headway: 1080
Vehicle Release: 555 at 838.0 seconds of observation.
Headway: 1800
Vehicle Release: 556 at 839.0 seconds of observation.
Headway: 1723
Vehicle Release: 557 at 841.0 seconds of observation.
Headway: 1655
Vehicle Release: 558 at 843.0 seconds of observation.
Headway: 1354
Vehicle Release: 559 at 844.0 seconds of observation.
Headway: 1366
Vehicle Release: 560 at 846.0 seconds of observation.
Headway: 1279
Vehicle Release: 561 at 847.0 seconds of observation.
Headway: 1575
Vehicle Release: 562 at 849.0 seconds of observation.
Headway: 1147
Vehicle Release: 563 at 850.0 seconds of observation.
Headway: 1342
Vehicle Release: 564 at 851.0 seconds of observation.
Headway: 1834
Vehicle Release: 565 at 853.0 seconds of observation.
Headway: 1656
Vehicle Release: 566 at 855.0 seconds of observation.
Headway: 1259
Vehicle Release: 567 at 856.0 seconds of observation.
Headway: 1430
Vehicle Release: 568 at 858.0 seconds of observation.
Headway: 1647
Vehicle Release: 569 at 859.0 seconds of observation.
Headway: 1981
Vehicle Release: 570 at 861.0 seconds of observation.
Headway: 1684
Vehicle Release: 571 at 863.0 seconds of observation.
Headway: 1295
Vehicle Release: 572 at 865.0 seconds of observation.
Headway: 1455
Vehicle Release: 573 at 866.0 seconds of observation.
Headway: 1923
Vehicle Release: 574 at 869.0 seconds of observation.

Headway: 1580
Vehicle Release: 575 at 870.0 seconds of observation.
Headway: 1070
Vehicle Release: 576 at 871.0 seconds of observation.
Headway: 1086
Vehicle Release: 577 at 873.0 seconds of observation.
Headway: 1662
Vehicle Release: 578 at 874.0 seconds of observation.
Headway: 1190
Vehicle Release: 579 at 876.0 seconds of observation.
Headway: 1214
Vehicle Release: 580 at 877.0 seconds of observation.
Headway: 1285
Vehicle Release: 581 at 878.0 seconds of observation.
Headway: 1924
Vehicle Release: 582 at 880.0 seconds of observation.
Headway: 1087
Vehicle Release: 583 at 881.0 seconds of observation.
Headway: 1091
Vehicle Release: 584 at 882.0 seconds of observation.
Headway: 1716
Vehicle Release: 585 at 884.0 seconds of observation.
Headway: 1585
Vehicle Release: 586 at 886.0 seconds of observation.
Headway: 1625
Vehicle Release: 587 at 888.0 seconds of observation.
Headway: 2000
Vehicle Release: 588 at 890.0 seconds of observation.
Headway: 1017
Vehicle Release: 589 at 891.0 seconds of observation.
Headway: 1038
Vehicle Release: 590 at 892.0 seconds of observation.
Headway: 1558
Vehicle Release: 591 at 893.0 seconds of observation.
Headway: 1695
Vehicle Release: 592 at 895.0 seconds of observation.
Headway: 1691
Vehicle Release: 593 at 897.0 seconds of observation.
Headway: 1714
Vehicle Release: 594 at 899.0 seconds of observation.

Simulated traffic flow with minimum and maximum headways of 1 and 3 seconds respectively

Initial Headway: 1528

Vehicle Release: 1 at 1.0 seconds of observation.

Headway: 1538

Vehicle Release: 2 at 3.0 seconds of observation.

Headway: 1545

Vehicle Release: 3 at 5.0 seconds of observation.

Headway: 2210

Vehicle Release: 4 at 7.0 seconds of observation.

Headway: 1562

Vehicle Release: 5 at 8.0 seconds of observation.

Headway: 2571

Vehicle Release: 6 at 11.0 seconds of observation.

Headway: 1302

Vehicle Release: 7 at 12.0 seconds of observation.

Headway: 2821

Vehicle Release: 8 at 15.0 seconds of observation.

Headway: 1865

Vehicle Release: 9 at 17.0 seconds of observation.

Headway: 1138

Vehicle Release: 10 at 18.0 seconds of observation.

Headway: 1423

Vehicle Release: 11 at 20.0 seconds of observation.

Headway: 1049

Vehicle Release: 12 at 21.0 seconds of observation.

Headway: 1842

Vehicle Release: 13 at 23.0 seconds of observation.

Headway: 1207

Vehicle Release: 14 at 24.0 seconds of observation.

Headway: 2371

Vehicle Release: 15 at 26.0 seconds of observation.

Headway: 2281

Vehicle Release: 16 at 28.0 seconds of observation.

Headway: 1283

Vehicle Release: 17 at 30.0 seconds of observation.

Headway: 1003

Vehicle Release: 18 at 31.0 seconds of observation.

Headway: 1062

Vehicle Release: 19 at 32.0 seconds of observation.

Headway: 1329

Vehicle Release: 20 at 33.0 seconds of observation.

Headway: 2756

Vehicle Release: 21 at 36.0 seconds of observation.

Headway: 1336

Vehicle Release: 22 at 37.0 seconds of observation.

Headway: 1190

Vehicle Release: 23 at 38.0 seconds of observation.

Headway: 1793

Vehicle Release: 24 at 40.0 seconds of observation.

Headway: 1836
Vehicle Release: 25 at 42.0 seconds of observation.
Headway: 2174
Vehicle Release: 26 at 44.0 seconds of observation.
Headway: 1470
Vehicle Release: 27 at 46.0 seconds of observation.
Headway: 1650
Vehicle Release: 28 at 47.0 seconds of observation.
Headway: 1649
Vehicle Release: 29 at 49.0 seconds of observation.
Headway: 1631
Vehicle Release: 30 at 51.0 seconds of observation.
Headway: 1726
Vehicle Release: 31 at 52.0 seconds of observation.
Headway: 2695
Vehicle Release: 32 at 55.0 seconds of observation.
Headway: 2317
Vehicle Release: 33 at 58.0 seconds of observation.
Headway: 1280
Vehicle Release: 34 at 59.0 seconds of observation.
Headway: 1809
Vehicle Release: 35 at 61.0 seconds of observation.
Headway: 2606
Vehicle Release: 36 at 63.0 seconds of observation.
Headway: 2009
Vehicle Release: 37 at 65.0 seconds of observation.
Headway: 2327
Vehicle Release: 38 at 68.0 seconds of observation.
Headway: 1710
Vehicle Release: 39 at 69.0 seconds of observation.
Headway: 1456
Vehicle Release: 40 at 71.0 seconds of observation.
Headway: 1182
Vehicle Release: 41 at 72.0 seconds of observation.
Headway: 1215
Vehicle Release: 42 at 73.0 seconds of observation.
Headway: 2851
Vehicle Release: 43 at 76.0 seconds of observation.
Headway: 1817
Vehicle Release: 44 at 78.0 seconds of observation.
Headway: 2551
Vehicle Release: 45 at 80.0 seconds of observation.
Headway: 1439
Vehicle Release: 46 at 82.0 seconds of observation.
Headway: 2329
Vehicle Release: 47 at 84.0 seconds of observation.
Headway: 2753
Vehicle Release: 48 at 87.0 seconds of observation.
Headway: 1023
Vehicle Release: 49 at 88.0 seconds of observation.

Headway: 2068
Vehicle Release: 50 at 90.0 seconds of observation.
Headway: 2351
Vehicle Release: 51 at 92.0 seconds of observation.
Headway: 1810
Vehicle Release: 52 at 94.0 seconds of observation.
Headway: 2421
Vehicle Release: 53 at 97.0 seconds of observation.
Headway: 2696
Vehicle Release: 54 at 99.0 seconds of observation.
Headway: 2507
Vehicle Release: 55 at 102.0 seconds of observation.
Headway: 1145
Vehicle Release: 56 at 103.0 seconds of observation.
Headway: 1794
Vehicle Release: 57 at 105.0 seconds of observation.
Headway: 2842
Vehicle Release: 58 at 108.0 seconds of observation.
Headway: 1460
Vehicle Release: 59 at 109.0 seconds of observation.
Headway: 1654
Vehicle Release: 60 at 111.0 seconds of observation.
Headway: 1770
Vehicle Release: 61 at 113.0 seconds of observation.
Headway: 2993
Vehicle Release: 62 at 116.0 seconds of observation.
Headway: 1305
Vehicle Release: 63 at 117.0 seconds of observation.
Headway: 1775
Vehicle Release: 64 at 119.0 seconds of observation.
Headway: 2926
Vehicle Release: 65 at 122.0 seconds of observation.
Headway: 2450
Vehicle Release: 66 at 124.0 seconds of observation.
Headway: 1396
Vehicle Release: 67 at 126.0 seconds of observation.
Headway: 1574
Vehicle Release: 68 at 127.0 seconds of observation.
Headway: 2367
Vehicle Release: 69 at 130.0 seconds of observation.
Headway: 2720
Vehicle Release: 70 at 132.0 seconds of observation.
Headway: 1191
Vehicle Release: 71 at 133.0 seconds of observation.
Headway: 2283
Vehicle Release: 72 at 136.0 seconds of observation.
Headway: 2383
Vehicle Release: 73 at 138.0 seconds of observation.
Headway: 2755
Vehicle Release: 74 at 141.0 seconds of observation.

Headway: 2007
Vehicle Release: 75 at 143.0 seconds of observation.
Headway: 2463
Vehicle Release: 76 at 145.0 seconds of observation.
Headway: 2204
Vehicle Release: 77 at 148.0 seconds of observation.
Headway: 2821
Vehicle Release: 78 at 150.0 seconds of observation.
Headway: 1296
Vehicle Release: 79 at 152.0 seconds of observation.
Headway: 1681
Vehicle Release: 80 at 153.0 seconds of observation.
Headway: 2665
Vehicle Release: 81 at 156.0 seconds of observation.
Headway: 1038
Vehicle Release: 82 at 157.0 seconds of observation.
Headway: 2754
Vehicle Release: 83 at 160.0 seconds of observation.
Headway: 1109
Vehicle Release: 84 at 161.0 seconds of observation.
Headway: 2222
Vehicle Release: 85 at 163.0 seconds of observation.
Headway: 2388
Vehicle Release: 86 at 166.0 seconds of observation.
Headway: 1483
Vehicle Release: 87 at 167.0 seconds of observation.
Headway: 2416
Vehicle Release: 88 at 170.0 seconds of observation.
Headway: 1924
Vehicle Release: 89 at 171.0 seconds of observation.
Headway: 1376
Vehicle Release: 90 at 173.0 seconds of observation.
Headway: 2776
Vehicle Release: 91 at 176.0 seconds of observation.
Headway: 1902
Vehicle Release: 92 at 178.0 seconds of observation.
Headway: 1468
Vehicle Release: 93 at 179.0 seconds of observation.
Headway: 2642
Vehicle Release: 94 at 182.0 seconds of observation.
Headway: 1478
Vehicle Release: 95 at 183.0 seconds of observation.
Headway: 1092
Vehicle Release: 96 at 184.0 seconds of observation.
Headway: 1811
Vehicle Release: 97 at 186.0 seconds of observation.
Headway: 1007
Vehicle Release: 98 at 187.0 seconds of observation.
Headway: 1138
Vehicle Release: 99 at 188.0 seconds of observation.

Headway: 2740
Vehicle Release: 100 at 191.0 seconds of observation.
Headway: 2786
Vehicle Release: 101 at 194.0 seconds of observation.
Headway: 2573
Vehicle Release: 102 at 196.0 seconds of observation.
Headway: 1712
Vehicle Release: 103 at 198.0 seconds of observation.
Headway: 1656
Vehicle Release: 104 at 200.0 seconds of observation.
Headway: 1264
Vehicle Release: 105 at 201.0 seconds of observation.
Headway: 2232
Vehicle Release: 106 at 203.0 seconds of observation.
Headway: 2150
Vehicle Release: 107 at 205.0 seconds of observation.
Headway: 2121
Vehicle Release: 108 at 208.0 seconds of observation.
Headway: 1965
Vehicle Release: 109 at 209.0 seconds of observation.
Headway: 2534
Vehicle Release: 110 at 212.0 seconds of observation.
Headway: 2918
Vehicle Release: 111 at 215.0 seconds of observation.
Headway: 2637
Vehicle Release: 112 at 218.0 seconds of observation.
Headway: 1310
Vehicle Release: 113 at 219.0 seconds of observation.
Headway: 2365
Vehicle Release: 114 at 221.0 seconds of observation.
Headway: 2263
Vehicle Release: 115 at 224.0 seconds of observation.
Headway: 1105
Vehicle Release: 116 at 225.0 seconds of observation.
Headway: 2921
Vehicle Release: 117 at 228.0 seconds of observation.
Headway: 1171
Vehicle Release: 118 at 229.0 seconds of observation.
Headway: 1583
Vehicle Release: 119 at 230.0 seconds of observation.
Headway: 2034
Vehicle Release: 120 at 232.0 seconds of observation.
Headway: 2271
Vehicle Release: 121 at 235.0 seconds of observation.
Headway: 2619
Vehicle Release: 122 at 237.0 seconds of observation.
Headway: 2671
Vehicle Release: 123 at 240.0 seconds of observation.
Headway: 1021
Vehicle Release: 124 at 241.0 seconds of observation.

Headway: 1647
Vehicle Release: 125 at 243.0 seconds of observation.
Headway: 2970
Vehicle Release: 126 at 246.0 seconds of observation.
Headway: 1131
Vehicle Release: 127 at 247.0 seconds of observation.
Headway: 1170
Vehicle Release: 128 at 248.0 seconds of observation.
Headway: 1845
Vehicle Release: 129 at 250.0 seconds of observation.
Headway: 2876
Vehicle Release: 130 at 253.0 seconds of observation.
Headway: 1481
Vehicle Release: 131 at 254.0 seconds of observation.
Headway: 1636
Vehicle Release: 132 at 256.0 seconds of observation.
Headway: 2789
Vehicle Release: 133 at 259.0 seconds of observation.
Headway: 2509
Vehicle Release: 134 at 261.0 seconds of observation.
Headway: 1663
Vehicle Release: 135 at 263.0 seconds of observation.
Headway: 1265
Vehicle Release: 136 at 264.0 seconds of observation.
Headway: 2821
Vehicle Release: 137 at 267.0 seconds of observation.
Headway: 1142
Vehicle Release: 138 at 268.0 seconds of observation.
Headway: 1769
Vehicle Release: 139 at 270.0 seconds of observation.
Headway: 2669
Vehicle Release: 140 at 273.0 seconds of observation.
Headway: 2469
Vehicle Release: 141 at 275.0 seconds of observation.
Headway: 2701
Vehicle Release: 142 at 278.0 seconds of observation.
Headway: 1545
Vehicle Release: 143 at 279.0 seconds of observation.
Headway: 2293
Vehicle Release: 144 at 282.0 seconds of observation.
Headway: 1916
Vehicle Release: 145 at 283.0 seconds of observation.
Headway: 2856
Vehicle Release: 146 at 286.0 seconds of observation.
Headway: 1407
Vehicle Release: 147 at 288.0 seconds of observation.
Headway: 1479
Vehicle Release: 148 at 289.0 seconds of observation.
Headway: 2042
Vehicle Release: 149 at 291.0 seconds of observation.

Headway: 2935
Vehicle Release: 150 at 294.0 seconds of observation.
Headway: 2226
Vehicle Release: 151 at 296.0 seconds of observation.
Headway: 1679
Vehicle Release: 152 at 298.0 seconds of observation.
Headway: 2535
Vehicle Release: 153 at 301.0 seconds of observation.
Headway: 1803
Vehicle Release: 154 at 302.0 seconds of observation.
Headway: 2891
Vehicle Release: 155 at 305.0 seconds of observation.
Headway: 2976
Vehicle Release: 156 at 308.0 seconds of observation.
Headway: 2817
Vehicle Release: 157 at 311.0 seconds of observation.
Headway: 2618
Vehicle Release: 158 at 314.0 seconds of observation.
Headway: 2691
Vehicle Release: 159 at 317.0 seconds of observation.
Headway: 1865
Vehicle Release: 160 at 318.0 seconds of observation.
Headway: 2917
Vehicle Release: 161 at 321.0 seconds of observation.
Headway: 1417
Vehicle Release: 162 at 323.0 seconds of observation.
Headway: 1925
Vehicle Release: 163 at 325.0 seconds of observation.
Headway: 1570
Vehicle Release: 164 at 326.0 seconds of observation.
Headway: 2326
Vehicle Release: 165 at 329.0 seconds of observation.
Headway: 2480
Vehicle Release: 166 at 331.0 seconds of observation.
Headway: 2923
Vehicle Release: 167 at 334.0 seconds of observation.
Headway: 2187
Vehicle Release: 168 at 336.0 seconds of observation.
Headway: 1378
Vehicle Release: 169 at 338.0 seconds of observation.
Headway: 1094
Vehicle Release: 170 at 339.0 seconds of observation.
Headway: 1288
Vehicle Release: 171 at 340.0 seconds of observation.
Headway: 1570
Vehicle Release: 172 at 342.0 seconds of observation.
Headway: 2355
Vehicle Release: 173 at 344.0 seconds of observation.
Headway: 1374
Vehicle Release: 174 at 345.0 seconds of observation.

Headway: 1651
Vehicle Release: 175 at 347.0 seconds of observation.
Headway: 2381
Vehicle Release: 176 at 349.0 seconds of observation.
Headway: 2714
Vehicle Release: 177 at 352.0 seconds of observation.
Headway: 2187
Vehicle Release: 178 at 354.0 seconds of observation.
Headway: 2673
Vehicle Release: 179 at 357.0 seconds of observation.
Headway: 1863
Vehicle Release: 180 at 359.0 seconds of observation.
Headway: 2157
Vehicle Release: 181 at 361.0 seconds of observation.
Headway: 1308
Vehicle Release: 182 at 362.0 seconds of observation.
Headway: 1754
Vehicle Release: 183 at 364.0 seconds of observation.
Headway: 1641
Vehicle Release: 184 at 366.0 seconds of observation.
Headway: 2598
Vehicle Release: 185 at 368.0 seconds of observation.
Headway: 1993
Vehicle Release: 186 at 370.0 seconds of observation.
Headway: 1900
Vehicle Release: 187 at 372.0 seconds of observation.
Headway: 2213
Vehicle Release: 188 at 374.0 seconds of observation.
Headway: 1811
Vehicle Release: 189 at 376.0 seconds of observation.
Headway: 2659
Vehicle Release: 190 at 379.0 seconds of observation.
Headway: 2511
Vehicle Release: 191 at 381.0 seconds of observation.
Headway: 2376
Vehicle Release: 192 at 384.0 seconds of observation.
Headway: 2022
Vehicle Release: 193 at 386.0 seconds of observation.
Headway: 1425
Vehicle Release: 194 at 387.0 seconds of observation.
Headway: 2186
Vehicle Release: 195 at 390.0 seconds of observation.
Headway: 2678
Vehicle Release: 196 at 392.0 seconds of observation.
Headway: 2425
Vehicle Release: 197 at 395.0 seconds of observation.
Headway: 1619
Vehicle Release: 198 at 396.0 seconds of observation.
Headway: 2720
Vehicle Release: 199 at 399.0 seconds of observation.

Headway: 2848
Vehicle Release: 200 at 402.0 seconds of observation.
Headway: 1134
Vehicle Release: 201 at 403.0 seconds of observation.
Headway: 2797
Vehicle Release: 202 at 406.0 seconds of observation.
Headway: 2012
Vehicle Release: 203 at 408.0 seconds of observation.
Headway: 2805
Vehicle Release: 204 at 411.0 seconds of observation.
Headway: 2755
Vehicle Release: 205 at 413.0 seconds of observation.
Headway: 1899
Vehicle Release: 206 at 415.0 seconds of observation.
Headway: 2009
Vehicle Release: 207 at 417.0 seconds of observation.
Headway: 1589
Vehicle Release: 208 at 419.0 seconds of observation.
Headway: 1919
Vehicle Release: 209 at 421.0 seconds of observation.
Headway: 1889
Vehicle Release: 210 at 423.0 seconds of observation.
Headway: 2875
Vehicle Release: 211 at 426.0 seconds of observation.
Headway: 1993
Vehicle Release: 212 at 428.0 seconds of observation.
Headway: 1853
Vehicle Release: 213 at 429.0 seconds of observation.
Headway: 2543
Vehicle Release: 214 at 432.0 seconds of observation.
Headway: 1940
Vehicle Release: 215 at 434.0 seconds of observation.
Headway: 1431
Vehicle Release: 216 at 435.0 seconds of observation.
Headway: 2651
Vehicle Release: 217 at 438.0 seconds of observation.
Headway: 2419
Vehicle Release: 218 at 440.0 seconds of observation.
Headway: 2275
Vehicle Release: 219 at 443.0 seconds of observation.
Headway: 1785
Vehicle Release: 220 at 445.0 seconds of observation.
Headway: 1651
Vehicle Release: 221 at 446.0 seconds of observation.
Headway: 2017
Vehicle Release: 222 at 448.0 seconds of observation.
Headway: 1932
Vehicle Release: 223 at 450.0 seconds of observation.
Headway: 2527
Vehicle Release: 224 at 453.0 seconds of observation.

Headway: 1857
Vehicle Release: 225 at 455.0 seconds of observation.
Headway: 1242
Vehicle Release: 226 at 456.0 seconds of observation.
Headway: 2017
Vehicle Release: 227 at 458.0 seconds of observation.
Headway: 2294
Vehicle Release: 228 at 460.0 seconds of observation.
Headway: 1631
Vehicle Release: 229 at 462.0 seconds of observation.
Headway: 2748
Vehicle Release: 230 at 465.0 seconds of observation.
Headway: 2919
Vehicle Release: 231 at 467.0 seconds of observation.
Headway: 1373
Vehicle Release: 232 at 469.0 seconds of observation.
Headway: 1875
Vehicle Release: 233 at 471.0 seconds of observation.
Headway: 1406
Vehicle Release: 234 at 472.0 seconds of observation.
Headway: 2532
Vehicle Release: 235 at 475.0 seconds of observation.
Headway: 1103
Vehicle Release: 236 at 476.0 seconds of observation.
Headway: 1979
Vehicle Release: 237 at 478.0 seconds of observation.
Headway: 2843
Vehicle Release: 238 at 481.0 seconds of observation.
Headway: 2830
Vehicle Release: 239 at 483.0 seconds of observation.
Headway: 1611
Vehicle Release: 240 at 485.0 seconds of observation.
Headway: 2182
Vehicle Release: 241 at 487.0 seconds of observation.
Headway: 2230
Vehicle Release: 242 at 490.0 seconds of observation.
Headway: 1799
Vehicle Release: 243 at 491.0 seconds of observation.
Headway: 1325
Vehicle Release: 244 at 493.0 seconds of observation.
Headway: 2711
Vehicle Release: 245 at 495.0 seconds of observation.
Headway: 1297
Vehicle Release: 246 at 497.0 seconds of observation.
Headway: 1808
Vehicle Release: 247 at 498.0 seconds of observation.
Headway: 2362
Vehicle Release: 248 at 501.0 seconds of observation.
Headway: 1836
Vehicle Release: 249 at 503.0 seconds of observation.

Headway: 1566
Vehicle Release: 250 at 504.0 seconds of observation.
Headway: 1523
Vehicle Release: 251 at 506.0 seconds of observation.
Headway: 1845
Vehicle Release: 252 at 508.0 seconds of observation.
Headway: 2003
Vehicle Release: 253 at 510.0 seconds of observation.
Headway: 2246
Vehicle Release: 254 at 512.0 seconds of observation.
Headway: 1522
Vehicle Release: 255 at 514.0 seconds of observation.
Headway: 1504
Vehicle Release: 256 at 515.0 seconds of observation.
Headway: 2946
Vehicle Release: 257 at 518.0 seconds of observation.
Headway: 2467
Vehicle Release: 258 at 520.0 seconds of observation.
Headway: 2937
Vehicle Release: 259 at 523.0 seconds of observation.
Headway: 2900
Vehicle Release: 260 at 526.0 seconds of observation.
Headway: 2624
Vehicle Release: 261 at 529.0 seconds of observation.
Headway: 1593
Vehicle Release: 262 at 531.0 seconds of observation.
Headway: 1345
Vehicle Release: 263 at 532.0 seconds of observation.
Headway: 2738
Vehicle Release: 264 at 535.0 seconds of observation.
Headway: 1889
Vehicle Release: 265 at 537.0 seconds of observation.
Headway: 2795
Vehicle Release: 266 at 539.0 seconds of observation.
Headway: 1805
Vehicle Release: 267 at 541.0 seconds of observation.
Headway: 1238
Vehicle Release: 268 at 542.0 seconds of observation.
Headway: 2968
Vehicle Release: 269 at 545.0 seconds of observation.
Headway: 1324
Vehicle Release: 270 at 547.0 seconds of observation.
Headway: 1926
Vehicle Release: 271 at 549.0 seconds of observation.
Headway: 2709
Vehicle Release: 272 at 551.0 seconds of observation.
Headway: 2575
Vehicle Release: 273 at 554.0 seconds of observation.
Headway: 1181
Vehicle Release: 274 at 555.0 seconds of observation.

Headway: 1544
Vehicle Release: 275 at 557.0 seconds of observation.
Headway: 2184
Vehicle Release: 276 at 559.0 seconds of observation.
Headway: 2894
Vehicle Release: 277 at 562.0 seconds of observation.
Headway: 2392
Vehicle Release: 278 at 564.0 seconds of observation.
Headway: 1432
Vehicle Release: 279 at 566.0 seconds of observation.
Headway: 1728
Vehicle Release: 280 at 567.0 seconds of observation.
Headway: 1465
Vehicle Release: 281 at 569.0 seconds of observation.
Headway: 1225
Vehicle Release: 282 at 570.0 seconds of observation.
Headway: 2839
Vehicle Release: 283 at 573.0 seconds of observation.
Headway: 1744
Vehicle Release: 284 at 575.0 seconds of observation.
Headway: 2087
Vehicle Release: 285 at 577.0 seconds of observation.
Headway: 2377
Vehicle Release: 286 at 579.0 seconds of observation.
Headway: 1547
Vehicle Release: 287 at 581.0 seconds of observation.
Headway: 1303
Vehicle Release: 288 at 582.0 seconds of observation.
Headway: 1878
Vehicle Release: 289 at 584.0 seconds of observation.
Headway: 1974
Vehicle Release: 290 at 586.0 seconds of observation.
Headway: 1165
Vehicle Release: 291 at 587.0 seconds of observation.
Headway: 2142
Vehicle Release: 292 at 589.0 seconds of observation.
Headway: 1237
Vehicle Release: 293 at 591.0 seconds of observation.
Headway: 2576
Vehicle Release: 294 at 593.0 seconds of observation.
Headway: 1106
Vehicle Release: 295 at 594.0 seconds of observation.
Headway: 1420
Vehicle Release: 296 at 596.0 seconds of observation.
Headway: 1659
Vehicle Release: 297 at 597.0 seconds of observation.
Headway: 2697
Vehicle Release: 298 at 600.0 seconds of observation.
Headway: 1682
Vehicle Release: 299 at 602.0 seconds of observation.

Headway: 2203
Vehicle Release: 300 at 604.0 seconds of observation.
Headway: 1362
Vehicle Release: 301 at 605.0 seconds of observation.
Headway: 2691
Vehicle Release: 302 at 608.0 seconds of observation.
Headway: 2613
Vehicle Release: 303 at 611.0 seconds of observation.
Headway: 2879
Vehicle Release: 304 at 614.0 seconds of observation.
Headway: 1218
Vehicle Release: 305 at 615.0 seconds of observation.
Headway: 2575
Vehicle Release: 306 at 618.0 seconds of observation.
Headway: 2217
Vehicle Release: 307 at 620.0 seconds of observation.
Headway: 1077
Vehicle Release: 308 at 621.0 seconds of observation.
Headway: 2600
Vehicle Release: 309 at 624.0 seconds of observation.
Headway: 2521
Vehicle Release: 310 at 626.0 seconds of observation.
Headway: 1437
Vehicle Release: 311 at 628.0 seconds of observation.
Headway: 2715
Vehicle Release: 312 at 631.0 seconds of observation.
Headway: 2156
Vehicle Release: 313 at 633.0 seconds of observation.
Headway: 1628
Vehicle Release: 314 at 634.0 seconds of observation.
Headway: 1541
Vehicle Release: 315 at 636.0 seconds of observation.
Headway: 1510
Vehicle Release: 316 at 637.0 seconds of observation.
Headway: 1748
Vehicle Release: 317 at 639.0 seconds of observation.
Headway: 2494
Vehicle Release: 318 at 642.0 seconds of observation.
Headway: 2198
Vehicle Release: 319 at 644.0 seconds of observation.
Headway: 1228
Vehicle Release: 320 at 645.0 seconds of observation.
Headway: 2296
Vehicle Release: 321 at 648.0 seconds of observation.
Headway: 2295
Vehicle Release: 322 at 650.0 seconds of observation.
Headway: 2306
Vehicle Release: 323 at 652.0 seconds of observation.
Headway: 2553
Vehicle Release: 324 at 655.0 seconds of observation.

Headway: 2851
Vehicle Release: 325 at 658.0 seconds of observation.
Headway: 1592
Vehicle Release: 326 at 660.0 seconds of observation.
Headway: 1488
Vehicle Release: 327 at 661.0 seconds of observation.
Headway: 1632
Vehicle Release: 328 at 663.0 seconds of observation.
Headway: 2163
Vehicle Release: 329 at 665.0 seconds of observation.
Headway: 1532
Vehicle Release: 330 at 666.0 seconds of observation.
Headway: 2715
Vehicle Release: 331 at 669.0 seconds of observation.
Headway: 1171
Vehicle Release: 332 at 670.0 seconds of observation.
Headway: 1313
Vehicle Release: 333 at 672.0 seconds of observation.
Headway: 2614
Vehicle Release: 334 at 675.0 seconds of observation.
Headway: 2469
Vehicle Release: 335 at 677.0 seconds of observation.
Headway: 1481
Vehicle Release: 336 at 679.0 seconds of observation.
Headway: 2462
Vehicle Release: 337 at 681.0 seconds of observation.
Headway: 2263
Vehicle Release: 338 at 683.0 seconds of observation.
Headway: 2408
Vehicle Release: 339 at 686.0 seconds of observation.
Headway: 2617
Vehicle Release: 340 at 688.0 seconds of observation.
Headway: 1993
Vehicle Release: 341 at 690.0 seconds of observation.
Headway: 2690
Vehicle Release: 342 at 693.0 seconds of observation.
Headway: 2779
Vehicle Release: 343 at 696.0 seconds of observation.
Headway: 1506
Vehicle Release: 344 at 697.0 seconds of observation.
Headway: 1294
Vehicle Release: 345 at 699.0 seconds of observation.
Headway: 2242
Vehicle Release: 346 at 701.0 seconds of observation.
Headway: 2552
Vehicle Release: 347 at 704.0 seconds of observation.
Headway: 2588
Vehicle Release: 348 at 706.0 seconds of observation.
Headway: 2333
Vehicle Release: 349 at 709.0 seconds of observation.

Headway: 1539
Vehicle Release: 350 at 710.0 seconds of observation.
Headway: 2440
Vehicle Release: 351 at 713.0 seconds of observation.
Headway: 2426
Vehicle Release: 352 at 715.0 seconds of observation.
Headway: 2279
Vehicle Release: 353 at 717.0 seconds of observation.
Headway: 2456
Vehicle Release: 354 at 720.0 seconds of observation.
Headway: 1767
Vehicle Release: 355 at 722.0 seconds of observation.
Headway: 2162
Vehicle Release: 356 at 724.0 seconds of observation.
Headway: 1808
Vehicle Release: 357 at 726.0 seconds of observation.
Headway: 2189
Vehicle Release: 358 at 728.0 seconds of observation.
Headway: 1921
Vehicle Release: 359 at 730.0 seconds of observation.
Headway: 1490
Vehicle Release: 360 at 731.0 seconds of observation.
Headway: 2282
Vehicle Release: 361 at 734.0 seconds of observation.
Headway: 1022
Vehicle Release: 362 at 735.0 seconds of observation.
Headway: 1673
Vehicle Release: 363 at 736.0 seconds of observation.
Headway: 1558
Vehicle Release: 364 at 738.0 seconds of observation.
Headway: 2468
Vehicle Release: 365 at 740.0 seconds of observation.
Headway: 2295
Vehicle Release: 366 at 743.0 seconds of observation.
Headway: 1315
Vehicle Release: 367 at 744.0 seconds of observation.
Headway: 1429
Vehicle Release: 368 at 745.0 seconds of observation.
Headway: 1059
Vehicle Release: 369 at 746.0 seconds of observation.
Headway: 2182
Vehicle Release: 370 at 749.0 seconds of observation.
Headway: 1071
Vehicle Release: 371 at 750.0 seconds of observation.
Headway: 2047
Vehicle Release: 372 at 752.0 seconds of observation.
Headway: 1071
Vehicle Release: 373 at 753.0 seconds of observation.
Headway: 2620
Vehicle Release: 374 at 755.0 seconds of observation.

Headway: 2035
Vehicle Release: 375 at 758.0 seconds of observation.
Headway: 2785
Vehicle Release: 376 at 760.0 seconds of observation.
Headway: 1960
Vehicle Release: 377 at 762.0 seconds of observation.
Headway: 1836
Vehicle Release: 378 at 764.0 seconds of observation.
Headway: 2196
Vehicle Release: 379 at 766.0 seconds of observation.
Headway: 1755
Vehicle Release: 380 at 768.0 seconds of observation.
Headway: 1239
Vehicle Release: 381 at 769.0 seconds of observation.
Headway: 1222
Vehicle Release: 382 at 771.0 seconds of observation.
Headway: 2157
Vehicle Release: 383 at 773.0 seconds of observation.
Headway: 1116
Vehicle Release: 384 at 774.0 seconds of observation.
Headway: 1839
Vehicle Release: 385 at 776.0 seconds of observation.
Headway: 2141
Vehicle Release: 386 at 778.0 seconds of observation.
Headway: 2121
Vehicle Release: 387 at 780.0 seconds of observation.
Headway: 1087
Vehicle Release: 388 at 781.0 seconds of observation.
Headway: 1314
Vehicle Release: 389 at 782.0 seconds of observation.
Headway: 1093
Vehicle Release: 390 at 784.0 seconds of observation.
Headway: 1384
Vehicle Release: 391 at 785.0 seconds of observation.
Headway: 2024
Vehicle Release: 392 at 787.0 seconds of observation.
Headway: 1542
Vehicle Release: 393 at 788.0 seconds of observation.
Headway: 1136
Vehicle Release: 394 at 790.0 seconds of observation.
Headway: 2322
Vehicle Release: 395 at 792.0 seconds of observation.
Headway: 1351
Vehicle Release: 396 at 793.0 seconds of observation.
Headway: 2365
Vehicle Release: 397 at 796.0 seconds of observation.
Headway: 2470
Vehicle Release: 398 at 798.0 seconds of observation.
Headway: 2334
Vehicle Release: 399 at 801.0 seconds of observation.

Headway: 2369
Vehicle Release: 400 at 803.0 seconds of observation.
Headway: 1141
Vehicle Release: 401 at 804.0 seconds of observation.
Headway: 2027
Vehicle Release: 402 at 806.0 seconds of observation.
Headway: 1434
Vehicle Release: 403 at 808.0 seconds of observation.
Headway: 2869
Vehicle Release: 404 at 810.0 seconds of observation.
Headway: 2510
Vehicle Release: 405 at 813.0 seconds of observation.
Headway: 1123
Vehicle Release: 406 at 814.0 seconds of observation.
Headway: 1974
Vehicle Release: 407 at 816.0 seconds of observation.
Headway: 1958
Vehicle Release: 408 at 818.0 seconds of observation.
Headway: 1329
Vehicle Release: 409 at 819.0 seconds of observation.
Headway: 1075
Vehicle Release: 410 at 820.0 seconds of observation.
Headway: 1387
Vehicle Release: 411 at 822.0 seconds of observation.
Headway: 2633
Vehicle Release: 412 at 824.0 seconds of observation.
Headway: 2038
Vehicle Release: 413 at 826.0 seconds of observation.
Headway: 1359
Vehicle Release: 414 at 828.0 seconds of observation.
Headway: 1236
Vehicle Release: 415 at 829.0 seconds of observation.
Headway: 1997
Vehicle Release: 416 at 831.0 seconds of observation.
Headway: 1000
Vehicle Release: 417 at 832.0 seconds of observation.
Headway: 1476
Vehicle Release: 418 at 834.0 seconds of observation.
Headway: 1414
Vehicle Release: 419 at 835.0 seconds of observation.
Headway: 1422
Vehicle Release: 420 at 836.0 seconds of observation.
Headway: 2471
Vehicle Release: 421 at 839.0 seconds of observation.
Headway: 1251
Vehicle Release: 422 at 840.0 seconds of observation.
Headway: 1890
Vehicle Release: 423 at 842.0 seconds of observation.
Headway: 2303
Vehicle Release: 424 at 844.0 seconds of observation.

Headway: 2596
Vehicle Release: 425 at 847.0 seconds of observation.
Headway: 2547
Vehicle Release: 426 at 850.0 seconds of observation.
Headway: 1552
Vehicle Release: 427 at 851.0 seconds of observation.
Headway: 1359
Vehicle Release: 428 at 852.0 seconds of observation.
Headway: 1008
Vehicle Release: 429 at 853.0 seconds of observation.
Headway: 1612
Vehicle Release: 430 at 855.0 seconds of observation.
Headway: 2615
Vehicle Release: 431 at 858.0 seconds of observation.
Headway: 2991
Vehicle Release: 432 at 861.0 seconds of observation.
Headway: 2000
Vehicle Release: 433 at 863.0 seconds of observation.
Headway: 1464
Vehicle Release: 434 at 865.0 seconds of observation.
Headway: 1669
Vehicle Release: 435 at 866.0 seconds of observation.
Headway: 2492
Vehicle Release: 436 at 869.0 seconds of observation.
Headway: 2032
Vehicle Release: 437 at 871.0 seconds of observation.
Headway: 1477
Vehicle Release: 438 at 872.0 seconds of observation.
Headway: 2498
Vehicle Release: 439 at 875.0 seconds of observation.
Headway: 1743
Vehicle Release: 440 at 877.0 seconds of observation.
Headway: 2231
Vehicle Release: 441 at 879.0 seconds of observation.
Headway: 2705
Vehicle Release: 442 at 882.0 seconds of observation.
Headway: 1000
Vehicle Release: 443 at 883.0 seconds of observation.
Headway: 2059
Vehicle Release: 444 at 885.0 seconds of observation.
Headway: 2439
Vehicle Release: 445 at 887.0 seconds of observation.
Headway: 1842
Vehicle Release: 446 at 889.0 seconds of observation.
Headway: 2914
Vehicle Release: 447 at 892.0 seconds of observation.
Headway: 2929
Vehicle Release: 448 at 895.0 seconds of observation.
Headway: 1593
Vehicle Release: 449 at 896.0 seconds of observation.
Headway: 1687
Vehicle Release: 450 at 898.0 seconds of observation.
Headway: 1958

One-Way AnovaTest for Total Garden-Agodi Gate road

SUMMARY

<i>Groups</i>	<i>Count</i>	<i>Sum</i>	<i>Average</i>	<i>Variance</i>
Simulated	10	18095	1809.5	742.5
Field	10	18234	1823.4	22958.49

ANOVA

<i>Source of Variation</i>	<i>SS</i>	<i>df</i>	<i>MS</i>	<i>F</i>	<i>P-value</i>	<i>F crit</i>
Between Groups	966.05	1	966.05	0.08152	0.778508	4.413873
Within Groups	213308.9	18	11850.49			
Total	214275	19				

One-Way AnovaTest for J Allen-Oke Bola road :

SUMMARY

<i>Groups</i>	<i>Count</i>	<i>Sum</i>	<i>Average</i>	<i>Variance</i>
Simulated	10	28040	2804	1674.444
Field	10	27950	2795	5121.556

ANOVA

<i>Source of Variation</i>	<i>SS</i>	<i>df</i>	<i>MS</i>	<i>F</i>	<i>P-value</i>	<i>F crit</i>
Between Groups	405	1	405	0.119188	0.733919	4.413873
Within Groups	61164	18	3398			
Total	61569	19				

One-Way AnovaTest for Odo Ona-Apata road

SUMMARY

<i>Groups</i>	<i>Count</i>	<i>Sum</i>	<i>Average</i>	<i>Variance</i>
Simulated	10	28205	2820.5	1666.944
Field	10	28159	2815.9	3240.544

ANOVA

<i>Source of Variation</i>	<i>SS</i>	<i>df</i>	<i>MS</i>	<i>F</i>	<i>P-value</i>	<i>F crit</i>
Between Groups	105.8	1	105.8	0.043118	0.837835	4.413873
Within Groups	44167.4	18	2453.744444			
Total	44273.2	19				